

# Broken Bodies, Places and Objects

New Perspectives on  
Fragmentation in Archaeology

**EDITED BY ANNA SÖRMAN,  
ASTRID A. NOTERMAN  
AND MARKUS FJELLSTRÖM**



# BROKEN BODIES, PLACES AND OBJECTS

*Broken Bodies, Places and Objects* demonstrates the breadth of fragmentation and fragment use in prehistory and history and provides an up-to-date insight into current archaeological thinking around the topic.

A seal broken and shared by two trade parties, dog jaws accompanying the dead in Mesolithic burials, fragments of ancient warships commodified as souvenirs, parts of an ancient dynastic throne split up between different colonial collections... Pieces of the past are everywhere around us. Fragments have a special potential precisely because of their incomplete format – as a new matter that can reference its original whole but can also live on with new, unrelated meanings. Deliberate breakage of bodies, places and objects for the use of fragments has been attested from all time periods in the past. It has now been over 20 years since John Chapman's major publication introducing fragmentation studies, and the topic is more present than ever in archaeology. This volume offers the first European-wide review of the concept of fragmentation, collecting case studies from the Neolithic to Modernity and extending the ideas of fragmentation theory in new directions.

The book is written for scholars and students in archaeology, but it is also relevant for neighbouring fields with an interest in material culture, such as anthropology, history, cultural heritage studies, museology, art and architecture.

**Anna Sörman** is a Wenner-Gren Postdoctoral Fellow at Nantes University (LARA/UMR 6566 CReAAH), France, and affiliated with Stockholm University, Sweden. Her research interests include the Bronze Age – Iron Age transition, craft organization and archaeological theory. Her ongoing research

centres on the use and deposition of fragmented metalwork in Bronze Age communities in north-western France and southern Scandinavia.

**Astrid A. Noterman** is a human osteologist and researcher at Stockholm University, Sweden, and a collaborative member of the CESCUM, France (UMR 7302). Her ongoing research centres on early medieval mortuary practices in western and northern Europe, Merovingian historiography and 19<sup>th</sup> century French archaeology. She is a founder member of the Scandinavian Archaeo-  
othenatology Working Group.

**Markus Fjellström** is a postdoctoral researcher at Lund University, affiliated to the Archaeological Research Laboratory at Stockholm University and Silvermuseet/INSARC in Arjeplog studying Late Palaeolithic and Mesolithic reindeer. His previous postdoctoral position was at Oulu University during the development of this book.

# BROKEN BODIES, PLACES AND OBJECTS

New Perspectives on Fragmentation  
in Archaeology

*Edited by*  
*Anna Sörman, Astrid A. Noterman and*  
*Markus Fjellström*

Cover image: photo taken by Anna Sörman

First published 2024

by Routledge

4 Park Square, Milton Park, Abingdon, Oxon OX14 4RN

and by Routledge

605 Third Avenue, New York, NY 10158

*Routledge is an imprint of the Taylor & Francis Group, an informa business*

© 2024 selection and editorial matter, Anna Sörman, Astrid A. Noterman and Markus Fjellström; individual chapters, the contributors

The right of Anna Sörman, Astrid A. Noterman and Markus Fjellström to be identified as the authors of the editorial material, and of the authors for their individual chapters, has been asserted in accordance with sections 77 and 78 of the Copyright, Designs and Patents Act 1988.

The Open Access version of this book, available at [www.taylorfrancis.com](http://www.taylorfrancis.com), has been made available under a Creative Commons Attribution-Non-Commercial-No Derivative Licence (CC-BY-NC-ND) 4.0 International license.

*Trademark notice:* Product or corporate names may be trademarks or registered trademarks, and are used only for identification and explanation without intent to infringe.

*British Library Cataloguing-in-Publication Data*

A catalogue record for this book is available from the British Library

ISBN: 978-1-032-39502-9 (hbk)

ISBN: 978-1-032-39499-2 (pbk)

ISBN: 978-1-003-35002-6 (ebk)

DOI: 10.4324/9781003350026

Typeset in Sabon

by codeMantra

The publication of the Open Access version of this book was funded by Stockholm University

# CONTENTS

<i>List of figures</i>	<i>ix</i>
<i>List of tables</i>	<i>xv</i>
<i>List of contributors</i>	<i>xvii</i>
<i>Preface</i>	<i>xxi</i>

## **Introduction**

1 Fragmentation in archaeological context – studying the incomplete <i>Anna Sörman, Astrid A. Noterman and Markus Fjellström</i>	1
---	---

## **PART I**

### **Fragmentation and funerary practices** **23**

2 Marking boundaries, making connections: fragmenting the body in Bronze Age Britain <i>Joanna Brück</i>	25
3 Breaking and making the ancestors. Fragmentation as a key funerary practice in the creation of urnfield graves <i>Arjan Louwen</i>	41

4	Bonded by pieces: fragments as means of affirming kinship in Iron Age Finland <i>Ulla Moilanen</i>	55
5	Revisiting, selecting, breaking and removing: incomplete and fragmented Merovingian reopened graves in Western Europe <i>Astrid A. Noterman</i>	69
6	Parted pairs: Viking Age oval brooches in Britain, Ireland, and Iceland <i>Frida Espolin Norstein</i>	86
<b>PART II</b>		
<b>Fragmentation and archaeological methods</b>		<b>101</b>
7	There is method in the madness – or how to approach fragmentation in archaeology <i>Bisserka Gaydarska</i>	103
8	Four problems for archaeological refitting studies. Discussion from the Taï Site and its Neolithic pottery material (France) <i>Sébastien Plutniak, Joséphine Caro and Claire Manen</i>	124
9	Describing identity: the individual and the collective in zooarchaeology <i>Emily H. Hull</i>	143
10	Fragmented reindeer of Stállo foundations: a multi-isotopic approach to fragmented reindeer skeletal remains from Adámvallda in Swedish Sápmi <i>Markus Fjellström</i>	157
11	House to house – fragmentation and deceptive memory-making at an early modern Swedish country house <i>Anna Röst</i>	173

**PART III****Fragmentation and the manipulation of objects** **187**

- 12 Multiple objects: fragmentation and process in the Neolithic of Britain and Ireland **189**  
*Andrew Meirion Jones*
- 13 Breaking, making, dismantling and reassembling: fragmentation in Iron Age Britain **205**  
*Helen Chittock*
- 14 Fusing fragments: repaired objects, refitted parts and upcycled pieces in the Late Bronze Age metalwork of Southern Scandinavia **224**  
*Karin Ojala and Anna Sörman*
- 15 Selective fragmentation: exploring the treatment of metalwork across time and space in Bronze Age Britain **243**  
*Matthew G. Knight*
- 16 Pieces of the past, fragments for the future – broken metalwork in Nordic Late Bronze Age hoards as memorabilia? **259**  
*Anna Sörman*
- 17 A man-of-war in pieces: fragmenting the *Rikswasa* of 1599 **274**  
*Mirja Arnshav*

**Concluding essay**

- 18 Fragmentation research and the fetishisation of independence **289**  
*John Chapman*

*Index* **311**



# Taylor & Francis

Taylor & Francis Group

<http://taylorandfrancis.com>

# FIGURES

2.1	Cist 2 at Dryburn Bridge, East Lothian (reproduced with permission of Dave Pollock, Andrew Dunwell, and the Society of Antiquaries of Scotland)	28
2.2	The belt hook of human bone from Wilsford Barrow G15, Wiltshire (© Wiltshire Museum)	30
2.3	The hoard, human bone and other finds from the fen edge at Bradley Fen, Cambridgeshire (reproduced with permission of Cambridge Archaeological Unit)	33
3.1	The urnfield mortuary process from an archaeological perspective (adapted version of Louwen 2021:fig. 3.7)	43
3.2	Burned pottery cup from an Early Iron Age urn at Deventer – ‘t Bramelt (left). Amber beads from a Late Bronze Age urn at Maastricht – Ambyerveld (right). One of the beads has been broken into two pieces. One half was missing from the grave (Dyselinck 2013, fig. 3.22)	46
4.1	A twisted penannular brooch with rolled terminals. The pin has been removed. A find from a cremation cemetery at Toijala, Kirkkomäki, Southern Finland (photo: Ulla Moilanen)	58
4.2	A tightly bent scramasax found from a cairn at Ylistaro Leikkimäki in Kokemäki, Western Finland. The handle parts have been removed (photo: Ulla Moilanen)	58
4.3	Cairns at the archaeological site of Harola, Eura, Western Finland. The IA site consists of over 700 stone cairns, of which only a few have been excavated. The structures contained ceramic shards, iron slag, unburnt animal bones, and a few fragments of cremated human bones (photo: Ulla Moilanen)	59

- 5.1 Illustration of grave 17 from Saint-Vit (France) with the fragmented and incomplete sword. The upper part of the weapon is lying against the left arm of the individual, while the pommel is located just above the head of the left femur. A set of bones was thrown back over the skull, as partially illustrated here (Urlacher et al. 2008:277) 74
- 5.2 Undisturbed male grave 3205 from Prény with an incomplete seax placed at the back of the head of the individual. In addition to the weapon, the assemblage was composed of a ceramic, four iron arrowheads and a flint (© Inrap, modified by A. A. Noterman) 76
- 5.3 Reopened grave 291 from Vendenheim with several anatomical sections missing. From the disturbances, only the left femur has been found several centimetres above the body, probably deposited by the reopeners on the container lid (© Antea archéologie, modified by A. A. Noterman) 77
- 6.1 Illustration of a strap dress with oval brooches (illustration: Frida Espolin Norstein) 87
- 6.2 Oval brooch (5960) from Dalvík (illustration by the author & by kind permission of the National Museum of Iceland) 88
- 7.1 Fragmentation studies of different materials: (a) bone (after Valera et al. 2019); (b) ground stone (after Martínez-Sevilla et al. 2020) (photograph by Miguel Ángel Blanco de la Rubia, by courtesy of the research group ATLAS of the University of Sevilla, Spain) 109
- 7.2 Sherds refitting: (a) the minimum space needed for appropriate refitting exercise; (b) different ‘life stories’ of conjoining sherds (Blanco-González & Chapman 2014a) 114
- 7.3 Reuse of fragments: (a) kintsugi (<https://commons.wikimedia.org/wiki/File:Kintugi.jpg>; Haragayato, CC BY-SA 4.0 <<https://creativecommons.org/licenses/by-sa/4.0/>>, via Wikimedia Commons), (b) ostracon (Ostracon with Phoenician inscriptions from Tyre, 3rd century BCE [https://commons.wikimedia.org/wiki/File:TerracottaOstracon-PhoenicianInscriptions\\_3rdCenturyBCE\\_NationalMuseumOfBeirut\\_RomanDeckert03102019.jpg](https://commons.wikimedia.org/wiki/File:TerracottaOstracon-PhoenicianInscriptions_3rdCenturyBCE_NationalMuseumOfBeirut_RomanDeckert03102019.jpg); RomanDeckert, CC BY-SA 4.0 <<https://creativecommons.org/licenses/by-sa/4.0/>>, via Wikimedia Commons) 116
- 8.1 Hierarchical classification of the layers of the MN phase. Inverted layers are highlighted by dashed lines and red labels. Data:  $x$ , a matrix with the number of similarity relationships (Table 8.3); distance:  $dist_{ij} = \max(x) - x_{ij}$ ; clustering method: UPGMA 131

8.2	Timeline of an archaeological assemblage: type of reasoning applied to determine past scenarios based on empirical observation (top) and uses of simulation (bottom)	138
10.1	The map shows the four sites from Adámvallda, Arjeplog parish, Sweden, by the Norwegian border (L1992:7475, L1992:7732, L1992:8161 and L1992:7894) (Liedgren 2003a, 2003b, 2004). The map has been retrieved and reworked from Lantmäteriet (© Lantmäteriet 2022)	158
10.2a	Carbon and nitrogen isotope values for the studied reindeer skeletal remains. Comparative isotope data has been added from Unna Saiva, Silbajåhkkå, Mørsviksbotn and Gollevárri (Salmi et al. 2015; Fjellström et al. 2019, 2021)	166
10.2b	Carbon and sulphur isotope values for the studied reindeer skeletal remains. Comparative isotope data has been added from Unna Saiva, Silbajåhkkå, Mørsviksbotn and Gollevárri (Salmi et al. 2015; Fjellström et al. 2019, 2021)	166
11.1	Årsta in 1667. Pencil drawing by Henrik Haij. (National Library of Sweden, CC0 1.0). The manor house exterior has not changed and appears very much the same today. Note the buildings in the background to the right: Old Årsta as it appeared a few years before its destruction	175
11.2	(a) The Årsta pews, still in Österhaninge parish church. Photo: Ivar Schnell. (b) The door from Årsta Manor, dated to around 1620. Photo: Nordiska muséets fotoateljé. (Nordiska muséet CC BY-NC-ND 2.5)	177
11.3	Fragments exposing and imposing deception. An elaborate stone slab used as a threshold for the “Mustering Barn”. It is most likely reused from a previous building, possibly the torn-down wing attributed to the King’s visit (photo: Anna Röst)	181
12.1	Above: RTI image of decoration on the Garboldisham macehead, Norfolk. Below: three views of the Garboldisham macehead (image: courtesy of Moyes Hall Museum)	192
12.2	RTI images of the Manx plaques from Ronaldsway (image: courtesy of the Manx Museum)	193
12.3	The carved stone ball from Clatchard, Fife. Above: RTI image showing revision of decoration on the knob of the ball. Below: two views of the carved stone ball from Clatchard (image: courtesy of National Museums Scotland)	196
13.1	An exploded diagram of the Kirkburn sword, East Yorkshire, showing the way numerous components were assembled (© Trustees of the British Museum)	211

13.2	The hypothetical positioning of the Grimthorpe shield fittings within the grave from which they were recovered (illustration: H. Chittock after Stead et al. 1969, 11 with kind permission). The dashed line represents Stead's interpretation of where the wooden or leather body of the shield may have lain, although no traces of this have survived	213
13.3	A photograph of the Torrs Pony Cap (Dumfries and Galloway, Scotland) (© National Museums Scotland)	217
14.1	Examples of the four types of modifications detected in Late Bronze Age metalwork from Sweden and Denmark. Fill-up: a belt dome from Grevie, Skåne (SHM 12937; Photo from The Swedish History Museum (SHM), CC-BY 2.5 SE). Fusing: a spectacle fibula from Senäte, Västergötland (SHM 1580; Photo by Stina Svantesson, Västergötlands Museum). Patching: a neck ring from Långbo, Södermanland (SHM 2674; Photo from The SHM, CC BY 2.5 SE). Upcycling: a razor from Ebberup Mark Denmark (from Madsen 1872; see also Thrane 2013). The modifications are marked with arrows	231
14.2	Three types of fused neck rings, with holes: Hårdshammar, Östergötland (OM. C 000635); cast-on: Altuna, Uppland (SHM 16018); and two fused by twisting two halves together: Svartarps gård, Åsle, Västergötland (SHM 22470; Photos from The SHM, CC-BY 2.5 SE; and Östergötlands Museum, CC-BY SA 4.0). The modifications are marked with arrows	233
15.1	A selection of deliberately damaged flat axeheads from Scotland. (a) The Hill of Finglenny hoard, Aberdeenshire; (b) an axehead from a cairn at Balnoon, Banffshire; (c) an axehead from Abdie, Fife (© National Museums Scotland)	246
15.2	A portion of the Bix hoard, Oxfordshire (PAS BERK-456EE1) (© Oxfordshire County Council, CC BY 2.0)	249
15.3	The Bloody Pool Hoard, Devon (photo: author, courtesy of Royal Albert Memorial Museum and Art Gallery, Exeter)	252
16.1	Parts of the Late Bronze Age hoard from Härnevi in central Sweden, containing a large portion of incomplete objects and often interpreted as a 'scrap hoard'. Note that not all breaks are ancient (illustration by Magdalena Forsgren, reprinted with kind permission)	260
16.2	Fragment of an unidentified object from the Härnevi hoard (photo by the author)	267

17.1	A large section of the bottom part of Rikswasa's hull was raised in the mid-1960s. It was then fragmented for the production of furniture, gadgets and memorabilia (photo: Jonas Berg, courtesy of National Maritime and Transport Museums, CC BY-SA).	279
17.2	The parts of <i>Rikswasa</i> keep circulating. In 2022 this clock was sold for c. 90 euros. The brass plaque states that the wood is a deck beam from the <i>Rikswasa</i> , built in Stockholm in 1599, foundered in 1623 and salvaged by the Nahlin brothers in 1962 (photo: Anders Båge Wahlström, Höganäs auktionsbyrå).	281
17.3	At the wreck site, the evidence of the breaking is evident. The most intact part of the remaining hull is slightly submerged into the sea floor and covered by loose pieces of timber (photo: Niklas Eriksson).	285
18.1	The relational identity triangle (source: author, re-drawn by Astrid A. Noterman)	292
18.2	Operational chains for the process of fragmentation (source: L. Woodard)	294
18.3	The entangled links of the repaired <i>Spondylus</i> bracelet, Grave 43, Varna cemetery (source: author)	296
18.4	A model for the movement of upland body fragments to the lowland enclosure of Herxheim (source: L. Woodard)	302



# Taylor & Francis

Taylor & Francis Group

<http://taylorandfrancis.com>

# TABLES

1.1	List of some interpretative approaches to fragmentation within archaeology and references to their appearance within this volume	4
1.2	A list of some of the most common interpretative approaches (of which many overlap) to fragments that can be found within the archaeological literature	6
6.1	Non-matching pairs of brooches from the western settlements. Museum numbers are in brackets. NMS: National Museums Scotland. BM: British Museum. NMI: National Museum of Iceland. NMD: National Museum of Denmark. DMAG: Doncaster Museum and Art Gallery (Table: Frida Espolin Norstein)	92
7.1	Fragmentation characteristics by material	106
7.2	Fragmentation characteristics by scale of investigation	112
7.3	Fragmentation characteristics by scale of investigation	113
8.1	Four types of methods for refitting studies according to the type of relationships processed and what is quantified (sets of fragments or sets of relationships between fragments)	125
8.2	Number of sherds (NR) and minimal number of individuals (MNI) in the Early Neolithic sub-phases EN1 and EN2 at the Tai site	127
8.3	Number of sherds according to layers (columns), divided into interlayer sets {similarity sets} and [connection sets] (rows) in the MN phase	129

8.4	Number and proportion of similarity relationships within and between the layers of the Middle Neolithic phase (966 relationships, 72 similarity sets)	130
8.5	Interpretation of the cohesive “strength” of refitting relationships as a function of the relative size of the connected fragments and the distance between their places of discovery	132
8.6	Properties of the fragmentation graphs built for the Cave and South entrance sectors (see Plutniak 2021b, Table 2, and the <i>archeofrag</i> documentation for details)	134
8.7	Cohesion and admixture values for EN1 and EN2 by sector and by weighting method (“x, y, z” is a shorthand for the distance factor)	134
10.1	Results from the stable carbon, nitrogen, sulphur and strontium isotope analysis of the reindeer skeletal remains from Adámvallda. Results of the quality assessment are also added to the table (concentrations of carbon, nitrogen, sulphur and strontium, as well as C:N, C:S and N:S ratios). Information about the finds from each Stállo foundation and hearth is added. Previous radiocarbon results are from Liedgren et al. 2007	164
14.1	The table shows some of the repaired LBA objects found in Sweden. Many of the hoards were discovered in the 19th century, and it is likely that fragments were sometimes neglected. SHM = Statens historiska museum; SLM = Södermanlands museum; UMF = Museum Gustavianum; KLM = Kalmar läns museum; VLM = Västmanland läns museum; OM = Östergötlands museum	228
16.1	The Late Bronze Age hoards included in this study, with fragmentation rates (*number of fragments in relation to the total number of items except casting debris, omitting breaks considered recent) ranging from about 50% to almost 90%	264

## CONTRIBUTORS

**Mirja Arnshav** is a research fellow at Stockholm University, Sweden. She is also a research coordinator at the Swedish National Maritime and Transport Museums and part of a project funded by the independent foundation Riksbankens Jubileumsfond entitled *The Lost Navy: Sweden's "blue" heritage c. 1450–1850*. Her research centres on the archaeology of the contemporary past, museums and maritime heritage studies. ORCID: 0000-0003-2037-3341

**Joanna Brück** is Professor of Archaeology at University College Dublin, Ireland. She is interested in the treatment of the human body, the social role of objects and the relationship between space and society. Her books include "Personifying prehistory: relational ontologies in Bronze Age Britain and Ireland" and "The social context of technology: non-ferrous metalworking in later prehistoric Britain and Ireland". ORCID: 0000-0001-8942-5504

**Joséphine Caro** is an archaeologist working on Early and Middle Neolithic societies in southern France through the analysis of ceramic productions. She studied at the Jean Jaurès University in Toulouse (France) where she defended her PhD in 2020. She is now an associate member of the TRACES laboratory (Toulouse). ORCID: 0000-0002-8526-9847

**John Chapman** is an Emeritus Professor of European Prehistory at Durham University. He started the research field of fragmentation in 2000 and published widely on fragmentation with Dr Gaydarska. He has recently published a synthesis of Balkan prehistory (*Forging identities in Balkan prehistory: individuals, individuals and communities, 7000–3000 BC*, 2020) alongside his memoir (*A life in Balkan archaeology*, 2021).

**Helen Chittock** is a Post-Excavation Project Manager for MOLA (Museum of London Archaeology), where she manages a range of commercial and research projects. Her doctoral and post-doctoral research focussed on decorative practices in Iron Age Britain and Europe, and her current research interests include later prehistoric art and archaeologies of repair. ORCID: 0000-0003-2419-3110

**Markus Fjellström** is a postdoctoral researcher at Lund University, affiliated to the Archaeological Research Laboratory at Stockholm University and Silvermuseet/INSARC in Arjeplog, studying Late Palaeolithic and Mesolithic reindeer. His previous postdoctoral position was at Oulu University during the development of this book. ORCID: 0000-0003-0332-7351

**Bisserka Gaydarska** is a Bulgaria-born European prehistorian working in the UK. Her wide-ranging research interests include material culture studies, identity, early urbanism, landscape archaeology, applications of archaeological science and fragmentation. She has conducted and led fieldwork and museum research in Bulgaria, Greece, Romania, Serbia and Ukraine. Her publications include 3 books, 9 co-edited volumes, 45 articles and 42 book chapters. ORCID: 0000-0002-6236-872X

**Emily H. Hull** is a zooarchaeologist who specialises in domestication studies, human-animal studies, non-human paleopathology, historical archaeology, and archaeological theory. She is currently researching non-human cultural and environmental histories and zooarchaeological theory at the University of Idaho. Hull previously worked as a postdoctoral scholar at the University of Oulu, Finland. ORCID: 0000-0002-5577-6899

**Andrew Meirion Jones** is Professor of Archaeology, Department of Archaeology and Classical Studies, Stockholm University, Sweden. He previously worked at the University of Southampton, UK (from 2001 to 2021). His research interests include the archaeology of Stone Age Europe, art and material culture, indigenous archaeologies, and digital imaging. He is currently working on a book examining time and archaeological images. ORCID: 0000-0002-4453-8369

**Matthew G. Knight** is Senior Curator of Prehistory at National Museums Scotland, responsible for the Chalcolithic and Bronze Age collections. He is particularly fascinated by the production, use, treatment and deposition of material culture, notably metalwork, and its meaning to Bronze Age communities. In 2022, he published a monograph exploring this subject entitled *Fragments of the Bronze Age* (Oxbow Books). ORCID: 0000-0001-6880-4417

**Arjan Louwen** studied 'Prehistory of Northwest Europe' at Leiden University and obtained his PhD in 2021 with his research into the funerary practices associated with urnfield graves in Northwest Europe. Arjan is still working at Leiden University, Faculty of Archaeology, as an Assistant Professor in field archaeology with research interests in 'Landscape Archaeology', 'Field Methods' and 'Bronze- and Iron Age'. ORCID: 0000-0002-1113-4165

**Claire Manen** is a CNRS research director in the TRACES laboratory, Toulouse, France. She works on the first farmers in the Western Mediterranean. She has directed the excavation and publication of the Taï site, whose long archaeological sequence of nearly three millennia allows us to trace the history of the communities and their environment. ORCID: 0000-0002-7827-8876

**Ulla Moilanen** is a postdoctoral researcher at the University of Helsinki, Finland, and a visiting researcher at the University of Turku, Finland. Her research covers a range of topics, from mortuary archaeology to material culture from the Iron Age to the postmedieval period. ORCID: 0000-0002-4213-4061

**Frida Espolin Norstein** is a postdoctoral researcher at Stockholm University, Sweden. Her research centres on Viking Age burial practices in Northern Europe, with a particular interest in artefact studies, ritual practices, regional variation, and the process of Christianization. ORCID: 0009-0002-7430-8895

**Astrid A. Noterman** is a human osteologist and researcher at Stockholm University, Sweden, and a collaborative member of the CESCUM, France (UMR 7302). Her ongoing research centres on early medieval mortuary practices in western and northern Europe, Merovingian historiography and 19th century French archaeology. She is a founder member of the Scandinavian Archaeo-othanatology Working Group. ORCID: 0000-0002-1189-9205

**Karin Ojala** is an Assistant Professor of Archaeology at Uppsala University, Sweden. Her research centres on contacts and interaction in Late Bronze Age and Early Iron Age Scandinavia. She is currently working with the Bronze Age–Iron Age transition, focussing on burial practices as well as the use of bronze and iron, including repairs and foreign objects. ORCID: 0000-0002-6694-8828

**Sébastien Plutniak** is a researcher at the French National Centre for Scientific Research (CNRS), affiliated with the CITERES laboratory (Tours, France), and a former fellow of the École française de Rome. Trained as a prehistoric archaeologist and a sociologist, his research focusses on current and past uses of formal and computer-based methods in the humanities and social sciences,

**xx** Contributors

studied from both practical, socio-historical and epistemological perspectives. ORCID: 0000-0002-6674-3806

**Anna Röst** completed her doctoral degree at Stockholm University in 2016. Her research interests include archaeology and memory, interdisciplinary perspectives on the past and microhistory. She is currently Curator of Årsta Manor Museum in Sweden and runs a project on the Early Modern archaeology of Årsta and the material culture of the nobility in the 17th century. ORCID: 0009-0007-1445-8951

**Anna Sörman** is a Wenner-Gren Postdoctoral Fellow at Nantes University (LARA/UMR 6566 CReAAH), France, and affiliated with Stockholm University, Sweden. Her research interests include the Bronze Age–Iron Age transition, craft organisation and archaeological theory. Her ongoing research centres on the use and deposition of fragmented metalwork in Bronze Age communities in north-western France and southern Scandinavia. ORCID: 0000-0003-3796-7066

# PREFACE

This volume grew out of a two-day international workshop entitled ‘Fragmentation in Archaeological Context’, organised by the editors through the Postdoctoral Archaeological Group at the Department of Archaeology and Classical Studies, Stockholm University, in the autumn of 2021. The papers presented conveyed important reflections and new ideas, leading us to propose further collaboration and a publication. As the original contributors have delivered and developed their ideas, a few additions have also been made by scholars who were not able to attend the meeting in person but who have useful things to say about this theme. With this collection of texts, we hope to show a broad variety of approaches to fragmentation in archaeology and to contribute to views on our incomplete source materials and the fragmented character of reality, both within and beyond archaeology.

We owe a debt of gratitude to several Swedish foundations that supported the original event and allowed for the stimulating meeting to take place: Riksbankens Jublieumsfond’s Initiation Grant and the ‘Black Box’ initiative by the Board of Human Science, Stockholm University. Generous support for producing and publishing this volume was provided by the Olle Engkvist Foundation and the Berit Wallenberg Foundation, to which we are very thankful.

Thanks also goes to Andrew M. Jones, professor at the Department of Archaeology and Classical Studies at Stockholm University, for his support and encouragement throughout this project, and to Judith Crawford and Emily H. Hull for their great job with English language revision. We are also grateful to the Routledge editorial team for their readiness and support throughout the editorial process.

Finally, the largest and warmest thanks go to the scholars who contributed to this volume. It has been a privilege to follow each other's ideas through this process. The meeting was something extra after years of pandemic restrictions, and the energy and investment by everybody in discussing and contributing to this topic have been very inspiring. We can only hope that it will now live on to inspire future readers.



# 1

## FRAGMENTATION IN ARCHAEOLOGICAL CONTEXT – STUDYING THE INCOMPLETE

*Anna Sörman, Astrid A. Noterman and  
Markus Fjellström*

### Archaeological perspectives on fragmentation

#### *From source-critical problem to interpretative potential*

In early antiquarian practice, fragmented remains were often viewed as a problem – the result of unfortunate damage, hindering archaeological reconstruction of the original whole. Fragmented remains recovered from excavations were commonly understood as rubbish; burials featuring post-depositional extraction of artefacts and skeletal parts were disappointedly described as ‘disturbed’, and broken objects were generally reconstructed before being put up for exhibition in museums. The complete was considered better than the broken. However, it has successively become clear to archaeologists that broken objects and bodies carry important information. The act of fragmentation, as ‘a breaking or separation into fragments’, was sometimes accidental, sometimes deliberate and sometimes strategic. Whatever the causes of the breakup of the whole, the broken pieces often live on with new meanings. Various forms of breakage and reuse of fragments have been attested from all periods of the past, from Neolithic figurines and relics in the Catholic church to modern souvenirs featuring pieces of the Berlin Wall.

Within archaeology, fragmentation became an eye-opener at the turn of the millennium through John Chapman’s pioneering work on the deliberate use of broken objects in prehistoric societies of Eastern Europe (Chapman 2000). Chapman showed that fragments were not just discarded scrap but were sometimes distributed among people and deposited in the landscape in order to manifest social relationships – to create enchainments. Chapman’s ‘fragmentation theory’ was stimulated by curious patterns in deposited

material, notably ceramic fragments from pots, seals and anthropomorphic figurines in different Neolithic and Chalcolithic communities in the Balkans (Chapman 2000; Chapman & Gaydarska 2007). The theory was also formulated as a critique (Chapman 2000:4) against some of the most functionalistic thinking in processual site formation studies, often assuming straightforward relationships between an ancient activity and its ‘waste’, deposited in archaeological formations (e.g. Binford 1962; Schiffer 1972; 1987; also see critique in Richards & Thomas 1984). This should also be seen in the context of anthropological insights into categorisation of ‘dirt’ and ‘waste’ as culturally relative (e.g. Douglas 1966; Moore 1981). Chapman highlighted how fragments played a part in creating people, places and objects. He also demonstrated how fragmented material culture could create references across time and place as one way of transmitting relationships and memories into new contexts (Chapman 2000).

It has now been over 20 years since the publication of Chapman’s work on fragmentation. Over the last decades, numerous case studies, debates and conceptual developments have taken archaeological insights on fragmentation practices and the use of fragmented materials in new directions (e.g. Knüsel & Outram 2004; Jones 2005; Brück 2006, 2016, 2017; Chapman & Gaydarska 2009; Brittain & Harris 2010; Rebay-Salisbury et al. 2010; Friesman 2012; Burström 2013; Lund 2013; Hansen 2016; van der Vaart-Ver-schoof 2017; Morton et al. 2019; Valera 2019; Chittock 2020; Guernsey 2020; Knight 2020; Nieuwhof 2020; Louwen 2021; Ahola et al. 2022; Chapman 2022). Archaeological thinking has moved a long way from automatically understanding fragments as ‘scrap’ or ‘waste’, and from the historical preference for highlighting only complete or heavily reconstructed specimens in exhibitions and publications. There are now numerous perspectives, studies and examples that acknowledge how fragments can tell stories and testify to historical processes. Fragmentation, whether deliberate or not, is the basic condition for most remains that we handle in archaeology. Not only do these perspectives contain fascinating examples of human strategic and deliberate use and reuse of fragments, but they always have stories to tell where breakage or decomposition is one part of the process of ever-changing materials and assemblages.

The aim of the following collection of texts is twofold: to show the breadth of fragmentation and fragment use in prehistory and history, and to provide an up-to-date insight into the current archaeological thinking around the topic. The volume is divided into three thematic parts: fragmentation and funerary practices; fragmentation and archaeological methods; and fragmentation and the manipulation of objects. These sections are preceded by this introduction, followed by a concluding essay by John Chapman. The examples and case studies in this book concern the chronological period between the Neolithic and the modern period and are almost exclusively European in

scope. They embrace the theme through a variety of approaches and methods that highlight the relevance of the fragmentation discussion in any context.

### ***Fragmentation – definitions of an expanding concept***

Actions and reactions in relation to broken materials encompass many interesting avenues for thought. In order to understand the width of this topic, we will start by defining two of the main concepts: fragmentation and fragment. Following the definition of each concept, we provide an overview, broad but not exhaustive, of different archaeological perspectives on fragments and fragmentation in archaeology.

Fragmentation encompasses all sorts of breakage, not only fragmentation that is intentional. This volume takes a broad interest in the broken and the incomplete – deliberate or unintentional. A lexical definition of fragmentation is “the action or process of breaking something into small parts” (*Cambridge Dictionary online*). This basic and instrumental definition can be complemented with definitions of the *consequences* or *implications* of such a process. In his concluding essay to this volume, John Chapman brings in Julia Guernsey’s (2020:112) observations from studies of Preclassic Mesoamerican human figurines and statues, where “(...) breakage was both a transformative, generative and a communicative act (...)”. In particular, the first two adjectives describe the incontestable consequences of fragmentation: it is transformative (it changes, often irreversibly, the material it breaks) and generative (it creates new entities in the form of pieces). As Chapman observes (p. 291 in this volume), this view could be extended to many, if not most, of the case studies presented in this book. In addition, archaeological research provides a multitude of approaches to fragmentation (Table 1.1).

Turning now to the results of the fragmentation – the fragments. The simple, lexical definition is “a small piece or a part, especially when broken from something whole” (*Cambridge Dictionary online*). However, this phenomenon also benefits from more in-depth reflection. First, it is, for example, interesting to reflect upon the difference between a fragment and any part (or ‘multiple actant’) of an assemblage, considering that assemblage theory and new forms of symmetrical and relational ontologies (e.g. Deleuze & Guattari 2004; DeLanda 2006; Harris 2018) have pointed out that the idea of stable wholes and categories is a misconception. If everything consists of shifting, interrelated constellations on various scales, then how can we argue there is a distinctive difference between what is fragmented and what is just in a constant but ever-changing state of becoming? Bisserka Gaydarska considers this question in the present volume and advances the argument that “if an overall commonly accepted design or form is affected, then we can recognise fragmentation. Thus, there will be no cross-culturally valid concepts of wholeness, while fragments can still be identified as such” (p. 104 in this

**TABLE 1.1** List of some interpretative approaches to fragmentation within archaeology and references to their appearance within this volume

<i>Studying fragmentation as:</i>	<i>Meaning/examples:</i>
Intentional vs. unintentional	Random and accidental breaking, natural decay, deliberate act... (All chapters concern fragmentation, either in intentional or unintentional form).
Practice	Breaking (Louwen; Moilanen; Plutniak et al.; Knight; Sörman; Arnshav), disarticulating (Brück; Noterman; Fjellström; Röst), splitting (Louwen; Fjellström), parting/dividing (Norstein), crushing, chopping, cutting (Moilanen), reconfiguring (Röst; Chittock; Ojala & Sörman; Arnshav), upcycling (Ojala & Sörman; Arnshav), dismantling (Röst; Chittock; Ojala & Sörman), separating (Hull), accumulating (Jones).
Technology	Skilled – unskilled (Röst; Chittock; Knight), reductive – additive (Gaydarska; Chittock; Chapman), complex – multi-stage (Brück; Hull; Fjellström; Knight; Arnshav), demanding of special techniques or tools (Brück; Noterman; Chittock; Ojala & Sörman; Knight; Arnshav).
Sensory experience	Discrete, memorable (Knight), violent, noisy, smelly (Noterman), visual (Chittock).
Communicative act	Participatory, performative, in front of an audience, as a specific event, in ritual or ceremony, involving specific actors/parties (Moilanen; Gaydarska).
Meaningful/Strategic act	Reuse/creating pieces for secondary use (Brück; Röst; Chittock; Ojala & Sörman; Knight; Sörman; Arnshav), enforcing social relations/creating enchainments (Brück; Louwen; Moilanen; Noterman; Norstein; Chittock; Sörman; Arnshav; Chapman), reinforcing group identity and sense of belonging (Moilanen), propaganda/underlining (prestigious) historical links (Brück; Röst; Sörman; Arnshav), economic gain/commodification (Sörman; Arnshav).
Disruptive act	Iconoclastic, defunctionalisation, disrespectful, fragmenting in order to symbolically ‘kill’, or fragmenting in order to break alliances or kinship ties (Brück; Moilanen; Noterman).
Constructive act	Constructing/configuring personhood (Brück; Louwen; Hull), life stories/materialising narratives (Norstein; Hull; Röst; Chittock; Sörman; Arnshav), maintaining kinship ties (Moilanen), creating notions of identity and place (Noterman; Röst; Chapman).
Accumulative process	Assemblages (Gaydarska; Chittock), creating multiple objects (Jones), creating enchainments in the form of ancestral links/histories/connections (Brück; Louwen; Moilanen; Noterman; Norstein; Jones; Chittock; Sörman; Chapman).
Taphonomic indicator	Re-fitting studies (Gaydarska; Plutniak et al.), post-burial interventions (Noterman), secondary deposition (Brück; Louwen; Noterman).

volume). Second, the concept of fragments versus a whole can also be used in a transferred sense for conceptualising the relation between body part versus body, and part versus ‘set’ (Chapman 2000:7, 46–47, fig. 1.4). Furthermore, archaeological research provides a multitude of overlapping perspectives when approaching fragments (Table 1.2).

These perspectives on fragmentation and fragments demonstrate the variation in how these phenomena can be studied archaeologically. As highlighted by Gaydarska (this volume), fragments can continue to live on and be strategically used, no matter whether they are created through intentional or random breakage. This stands as an important and nuanced insight in relation to the ‘fragmentation premise’ developed by Chapman and Gaydarska (2007, 2009), where much emphasis was placed on the intentional breakage in the process of strategic fragment use. As indicated by the approaches listed above, meaning can be created at various points during the handling of fragmented matter: in the event of breakage, in the process of fragmentation, in the practice surrounding the fragmented parts directly after the break, or through non-associated practices following the rediscovery of these pieces at a later point in time. This highlights an important point about temporality: fragmentation can have importance as an act or event for the fragments that were created, but fragments can also be used in practices totally unrelated to the original breakage. In this sense, our terminology around fragmentation could be further developed to capture differences in the processes of fragmentation and the itineraries of the resulting fragments.

### *The ontological and existential qualities of fragments*

Among the perspectives listed above, we can see that some themes touch upon the more existential values of fragments, with particular relevance in relation to the archaeological pursuit. First, in an ontological and philosophical sense, the world contains residues and incomplete pieces of past realities. This affects us and stimulates reactions and thoughts. Pastness through fragments and ruins arouses curiosity about what was once there and evokes ideas of there being something more to reality than what we can perceive in the present (Olivier 2011; Burström 2013; Schnapp 2020; Demoule et al. 2021). In our time and culture, these reactions are tightly tied to and answered by the disciplines of archaeology and history. At the same time, there is also a growing awareness of how ideas of our own modern culture have presented the complete and spotless, while often discarding broken and used materials as weak or waste (e.g. Chapman & Gaydarska 2007; Brück 2017:144; Chittock 2020).

Living in this bricolage of fragments from different pasts has inspired various kinds of approaches and underlined experiences, as illustrated by the fruitful archaeological studies of ‘the past in the past’ and the role of material

**TABLE 1.2** A list of some of the most common interpretative approaches (of which many overlap) to fragments that can be found within the archaeological literature

<i>Fragments as:</i>	<i>Meaning/examples:</i>
Referencing their original whole	Memory is related to origin (transmitted, invented and mythical), with the original whole being identifiable from the fragment. Examples of ‘wholes’: a body, an object, a set of objects, a construction, a monument, a place/raw material outcrop/landscape feature.
Unrelated to/going beyond their original whole	Used for new purposes and no importance placed on origin or perceived origin/the original whole is unidentifiable from the fragment.
Reinforcer of social relations	Creating or embodying enchainments, tokens of hospitality, tokens of friendship, kinship, alliances or deals.
Constructive	Constructing personhood, life stories, notions of identity and place.
Material memories	Real, fake, manipulated, enhanced; relating to personal, institutional, communal, living or mythical memory.
Present vs. absent	Archaeologically present (orphan) versus absent (missing) fragments, meaning that fragments from the same whole had different itineraries after the break.
Dispersed/distributed/circulated	Fragments found in multiple locations were identified as belonging together, meaning that fragments from the same whole had different itineraries and uses after the break. Fragments circulating as currency.
Recycled/reused material	Raw materials or modules to be integrated into new forms.
Variably fragmentable	Composite objects that can be easily parted or disassembled versus materials breaking into more random pieces; fragile materials versus massive materials breaking with more difficulty; the partibility of bodies subjected to different post-mortal treatments (e.g. cremation) or in different stages of decomposition.
As pieces of different types of wholes	As fragments of a material mass or natural (such as flakes of a rock), as pieces of a broken object (such as half a sword, a foot of glass or a shard of a pot), as parts of a composite object, as elements of a large construction, as pieces of a body, as pieces from a scattered ‘set’ of associated objects or features or as pieces of material extracted from the same landscape feature.
‘Multiple objects’	In constant forms of becoming, stages in a process (see Jones this volume).

culture in memory processes (e.g. Bradley & Williams 1998; Bradley 2002; Jones 2007, this volume; Chittock this volume) (see also Lowenthal 1989). Similarly, fragments as material memories are related to questions about the archaeological project itself. Archaeology is just yet another way to handle fragmented materials from the past in the present. In modern culture and scientific discourse, historical disciplines are approaching fragments of the past by ordering, classifying and trying to explain past societies, and by protecting and exhibiting such remains through politically sanctioned heritage discourses. This focus and the tendency to think of time as linear and separated episodes (e.g. Lucas 2005; Olivier 2014) are probably one of the reasons why other stories possible to tell through fragments, those of secondary uses, natural decay, dispersal or later interventions, etc., are less exploited than the narratives relating to the original wholes.

This brings us to the second point of *how* archaeology and the heritage sector handle fragments of past objects and bodies, which in themselves have stories to tell. This meta-perspective – turning questions of fragmentation towards our practice as archaeologists – can reveal interesting phenomena and processes. Fragments that were broken or divided among contestants in colonial heritage ventures are now distributed among museum institutions in several modern nations (e.g. Shefton 1985). In a similar way, entire monuments, assemblages or pieces of objects were divided and shared between geopolitical stakeholders (e.g. Hicks 2020). Displayed in the main collections during the 19th and 20th centuries, they were both trophies of glory and tokens of scientific advances. Moreover, they were hints of geopolitical dominance and a way to inscribe one's own nation's history into the framework of the Great Civilisations (Bourguet et al. 1998; Díaz-Andreu 2007; Gran-Aymerich 2007), and hence a tool for the ideology of imperialism (Hicks 2020). This dispersed heritage is in itself an example of a more recent practice of fragmentation (see also Arnshav this volume). Most objects have remained separated, but sometimes they have been joined in new exhibitions or after repatriation to states in the original find-regions (e.g. Shefton 1985; Rondot 2022:144). The potential of fragmented materials to tell the meta-story of archaeology and colonialism is an important issue to develop.

Another example of fragmentation within the heritage sector is the separation between skeletal remains and bone artefacts in museum storage. Generally, pieces of human and animal bodies are stored separately and separated from other items in the same context depending on whether they have been reworked into objects or not (Karlsson 2016:9). Animal and human remains from the same set of finds are usually studied independently of each other, in every sense of the word. Expected to require different professional skills, they are analysed in different rooms, even sometimes in different buildings; they are examined at different times of the post-excavation process, presented in a

different way in the final report, and discussed separately in conferences. This fragmentation in the study of bone assemblages is barely questioned today, nor are issues concerning large fragmented animal bone material (however, see Hull this volume). Even though separated categories of finds might be reassembled again before exhibition, the fact that we keep supporting these fragmentation practices when handling archaeological source material reveals our own systems of thought.

***Broken bodies – funerary practices, personhood and secondary use of human body parts***

Human bodies have a certain degree of individual variety and uniqueness when it comes to details. However, the overall form of the human body can be universally recognised.<sup>1</sup> Also, human body parts – primarily in the form of disarticulated dead bodies – have been fragmented, manipulated and circulated in a variety of forms throughout prehistory, history and the present. Even if the industrialised nations within monotheistic religious traditions mostly live in the paradigm of the sacred and unpartable body, there are different traditions in cultures with other outlooks as well as new trends in cremation practices in the Western world where bodies are more subjected to manipulation after death than is often believed or acknowledged (e.g. Williams 2011; Anthony 2016).

Jennifer Kerner's research on post-mortem body manipulations has shown that the partibility of the deceased is in fact a longstanding story (Kerner 2018). Fragmentation is an integral part of the funeral ritual in some modern communities, with dead individuals positioned in a certain way in the tombs to facilitate the recovery of body parts, while the graves themselves are adapted for post-mortem handling (e.g. Dumas-Champion 1995). Archaeological contexts often provide dry skeletal remains, free of organic material such as soft tissues and organs, limiting the discussion on the fragmentation of the organic part of human bodies. Yet, the separation of the body from its entrails is attested in written and ethnographic sources, not necessarily in connection with the simple desire to annihilate the putrefaction of the body (Kerner 2018:178–188). For the 12th–14th centuries, the mortuary traditions have even been referred to as a 'culture of fragmentation' (Westerhof 2004).

A further example is the forceful repressive function of the 'incomplete' body in life (e.g. colonial forces cutting off hands in the Belgian Congo; hand-cutting as a punishment for theft) and to live on with this visible incompleteness in a culture where the missing of that particular piece stands so clearly for repression, guilt and oppression. On the other end of the spectrum, these hands, like other body parts in collections (anatomical, ethnographic, medical, curiosity cabinets, etc.) were displayed in Western contexts to underline

domination, racial world order and sometimes to boost personal or scientific pride. In antiquity, cutting off hands was not only used as a punitive measure but also used as a visual marker for grave robbers (Noterman 2016:192–193). In his thought-provoking publication on the notion of *corpse*, Louis-Vincent Thomas points out all the ambiguity of body mutilations, involve contempt and disrespect but may also be ritual in many societies. In biblical narratives, there are several examples of this; after being butchered and pulled apart by dogs, Jezebel is denied her individuality in death (Jégou 2015). There are also iconic examples in European history, such as the corpse of the pope Formosus, which was exhumed, brought to trial and condemned and had several fingers amputated in a symbolic gesture to deny him his ritual rights (Thomas 1980:109–110).

Examples of divided, manipulated bodies and the circulation of body parts are numerous in European modern and pre-modern history. Reasons varied and included, for example, the protection that a piece of a body could offer by wearing a dead man's bone as an amulet to fight fever or bring luck (Jacob 1859:96–97). Other examples involved cures through the ingestion of specific parts, as in 17th and 18th century *pharmacopoeia* manuals that recommended using fragments of the skull of a man who died from a violent death (execution) to cure epilepsy (Lémery 1697). Going further back in time, the examples multiply, spanning from the deliberate fracturing of body parts into relics as remnants of specific cults within the Catholic church (e.g. Kjellström 2017:171) to arrangements of dismembered, incomplete remains in collective assemblages of megalithic tombs (e.g. Tornberg 2022) and the intricate handling of cremated and curated human remains in Bronze Age mortuary traditions (e.g. Brück 2006, 2017, this volume; Ojala & Röst 2021; Louwen this volume), to mention only some.

Breaking bodies and using the parts might be ways to link ancestors with specific places, persons or phenomena in the present. They can serve to activate, manipulate, or eradicate memory; to relate and make claims on ancestry, history or terrain; to be extracted for reuse – magically, religiously, medically, scientifically or for propagandistic purposes, for example (see Brück this volume; Moilanen this volume; Noterman this volume; Hull this volume). Parts of bodies can also serve to link the dead with the living, keeping a connection between two worlds or recreating a connection that death had momentarily broken.

### ***Fragments – their properties and how to study them***

The properties of various materials and bodies have a major impact on how they lend themselves to fragmentation and how they behave as fragments (Chapman 2000:23, 71; Gaydarska this volume). Significant visual qualities that are sometimes harnessed in fragmentation and fragment use are,

for example, peculiar/exotic forms and decorations (Chapman 2000:65) and age/patina (Chittock 2020). Properties such as durability, density, shape, proneness to decay, hardness, etc. will impact the likelihood of breakage of things and bodies, the means needed to fragment them, and the characteristics of the fragments produced. The importance of these qualities is a growing insight in archaeological studies of fragmentation and is also visible in the studies presented in this volume. This is presumably partly influenced by new strands of thought, such as new materialism and posthumanism, which urge us to reflect on material properties, and co-dependences between material and form, and the effects and affects of things.

The range of material properties and conditions given by the material form is one of the points that emerge from various examples and materials discussed in this volume. The breakability of objects varies between, for example, ceramic pots (Gaydarska this volume; Plutniak et al. this volume), animal bodies (Fjellström this volume; Hull this volume), massive bronzes (Knight this volume; Sörman this volume) or composite metalwork objects (Chittock this volume; Ojala & Sörman this volume). A cremated human body (Brück this volume; Louwen this volume) does not present the same qualities for fragmentation as a decomposing human or skeletal human body in an inhumation grave (Brück this volume; Moilanen this volume; Noterman this volume) and differs yet again from large architectonic elements salvaged from old houses or shipwrecks (Röst this volume; Arnshav this volume). All these materials indicate different strategies and technologies for fragmentation in the past.

Fragments of different materials also require different types of methodological considerations from archaeologists studying them in the present. Typically, easily breakable and frequent (mass)materials such as faunal skeletal remains, ceramics and lithic debris are more often subjected to re-fitting studies, stratigraphic analyses and quantitative reconstruction efforts (e.g. Gaydarska this volume; Plutniak et al. this volume; Hull this volume; Fjellström this volume). Here, the possibility to scientifically trace common origins (through similarities in microstructure, chemical composition, isotopic signatures, aDNA, etc.) also creates varying conditions for various materials. However, it should be noted that provenance from the same original whole might have been perceived differently in the past, as suggested by examples where 'fake' fragments are, knowingly or unknowingly, given the same value as 'authentic' pieces (e.g. Hunter & Biekert 2014; Thunø 2018:163; see also Röst this volume).

Material properties also have implications for the technology of breaking, and the scale and skill involved (Gaydarska this volume). Ceramics can be broken without special skill, while massive metalwork is harder to break and breaks differently depending on the technique applied (Knight 2019, 2020, this volume), whereas composite metalwork designs might instead enhance

the breakability and inspire fragmentation (Chittock 2021, this volume; Ojala & Sörman this volume). Bodies that have been burned (cremated), skeletonised, processed in some way or have reached an advanced stage of decay are more easily fragmented (reconfigured) than the newly deceased (Brück this volume; Noterman this volume). This has consequences for thinking about skill, the fragmentation as an event, and the sensual experiences surrounding the break, but also for the end result (Knight 2022; Gaydarska this volume). How many fragments are created, what are the properties of these parts, and are the qualities and characteristics of the parts the same or different?

In previous works, objects such as figurines have been emphasised as possible to break into pieces of very different shapes and visual properties, opening for complex forms of association (e.g. Chapman 2000; Chapman & Gaydarska 2007:69–70). The character of fragments influences their potential use and sets certain limits for interaction with them. For example, different treatments of Neolithic figurine parts in material from the Balkans have been linked to configurations of gender identities (Chapman 2000:68–79; Chapman & Gaydarska 2007: Chapter 3). Other examples are the special handling of hands and heads in the Late Bronze Age cremation graves in central Sweden (Röst 2016), which is a pattern not yet fully understood, and the special attention to heads in some reopening practices in early medieval row-grave fields (Noterman this volume). Furthermore, in several cultural contexts, fragmentation of objects with a particular symbolism, such as stamps, seals or friendship tokens, has been identified as meaningful in confirming alliances or joint agreements (e.g. Chapman 2000; rituals involving early medieval belts, see Noterman this volume).

Here, we also note the importance of the shape of the original whole, as certain wholes, such as more uniform and massive objects, might be less partible and therefore more remarkable when actually fragmented. Rings are often involved in enchainment practices, with and without the involvement of fragmentation, and examples are found cross-culturally (e.g. Swift 2012; Ahola et al. 2022; Chapman this volume; Sörman this volume). One might ask if certain shapes, such as rings, would be more readily subjected to these kinds of practices. Would the properties of round, solid or symmetrical shapes evoke other notions when forming wholes vis-a-vis parts, and is this quality and potential symbolism harnessed? Here we might also think of human bodies and non-human animal bodies, which might be seen as presenting quite distinct and historically continuous ‘wholes’. Another strong potential for symbolism can be found in breaking the coupling of a pair, consisting of two symmetrical pieces; this seems to have occurred in some cases of Scandinavian Viking oval brooch sets (Norstein this volume) and discs on some Nordic Late Bronze Age ‘spectacle fibulas’ (Ojala & Sörman this volume). The properties of wholes and parts and the incentives for choosing

to use certain wholes for fragmentation practices certainly differ in cultural contexts and situations and are thereby key to archaeological analysis.

Affordances of patina and visual signs of age also play a major role in many of the examples where fragments come into secondary use. This underlines the often intimate and intricate link between fragmented matter and memories of the past. Examples from this volume include decayed objects from sets of grave goods in a reopened grave, which might have special significance for their obvious origins (Noterman this volume); the fragments of old architectural parts strategically reused at the Årsta mansion, partly appreciated for their ‘old’ style (Röst this volume); and Late Bronze Age metal objects accumulated in some of the so-called ‘scrap hoards’, which were recognisable and probably tied to ancestral memories (Brück this volume; Sörman this volume). Further, oak salvaged from sunken battleships became souvenirs, often in masculine spheres evoking naval life and military pride, and were exploited for the very reason of the colour and patina of the ‘black oak’, timber that had once sunk to the seafloor and was later recovered (Arnshav this volume). Age and patina are significant sometimes, but might not always be sought after or exploited in fragmentation.

Another factor is ‘otherness’ or ‘specificness’ involved in the itinerary of the object or the form, as for example in fragments of obvious non-local objects and imports, or special patterns or shapes that are perhaps sometimes more potent for use in strategic links through fragmentation (Chapman 2000: 64–65). One example here is the sets of Viking oval brooches used in Scandinavian female costume, where single parts or fragments could sometimes be used in West Atlantic colonies to evoke memories of the journey and origins of women from previous generations (Norstein this volume). The special character of valued fragments can also be enhanced by adding to or configuring their appearance, such as by assembling them into composite objects that tell visual stories (Chittock 2020, this volume). Other examples involve placing them on a special base or pedestal, such as souvenirs of the Berlin Wall mounted on small plaques and provided with a label, or setting them in special fittings, capsules or feretories, such as relics in the Catholic cult. Such additions underline the exclusiveness and the special trajectories of the fragments, and their ‘specialness’ is enhanced by reconfiguring the object itself.

A last point considered here is a reflection on what is lost and what is gained after fragmentation. What aspects and qualities of the original whole are still perceivable in the piece (its colours, its identity, its shape, its function or its origin)? A broken pot can no longer serve as a container but can be carried and stored in small places (Brück 2016, 2017; Louwen this volume; Gaydarska this volume). A fragment with a handle, a hole or a loop could be suspended from a hook or on a string. A shipwreck can no longer sail but can fit in a home as a piece of furniture (Arnshav this volume). A bronze vessel

fragment can no longer be used for banquets, but can be shaped into a new, smaller object (Thrane 2013; Ojala & Sörman this volume). A fragmented body can no longer act as a living individual in relation to others but can be intermingled and physically mixed with the body of another individual (Brück this volume; Louwen this volume). Many important observations can be made by posing the question, what can fragments *do*? (c.f. Chittock 2021). Their capacity to be multiplied, portable, combinable, etc. demonstrates the qualities and possibilities that fragmentation brings about and that we must try to evaluate. Changing from whole to fragment means losing some characteristics but gaining others. As emphasised throughout this volume, the result of fragmentation and breaking is transformation rather than loss.

### ***Fragments and their relations – assemblages, new materials and post-human perspectives***

Climate change and the environmental changes that we are facing today have opened up archaeology to a new field studying the effects of the Anthropocene and its materiality. With finds made through glacial archaeological surveys (Callanan 2012, 2016), new categories of fragmented objects and animal remains are emerging from the melting ice and snow, formed in special conditions. The findings of whole organic artefacts, ecofacts and fauna historic finds provide new understanding of fragmented objects, whether they were unintentionally or deliberately broken, intentionally deposited or accidentally misplaced. Modern fragments also give us an unfortunate insight into the consequences of worldwide consumerism, with fragmented plastic objects and (macro- and micro-) plastic fragments floating ashore, also far away from areas where these plastics were used, such as the Arctic (Pétursdóttir 2019). The archaeology of plastics is a currently developing field that studies how plastics can be used as a stratigraphic indicator of the Anthropocene (Zalasiewicz et al. 2016). According to Jan Zalasiewicz et al. (2016:8), plastics seem to be gaining terrain in the archaeological field, and plastic fragments are increasingly used as stratigraphic markers in recently disturbed or modern deposits. Recently, analyses of fragmented plastic debris in terrestrial deposits have illuminated the contemporary use and pollution of heritage sites (Mytum & Meek 2021:208–209).

There is currently a growing body of theory that calls attention to the intermingled character of all agents (human and non-human animals, ‘nature’, things) in the creation of reality. These developments in science and philosophy can partly be understood as responses to and insights following the accelerating climate crisis on Earth. More than before, the changing climate highlights the embedded human position in ecological systems, inter-species dependencies and the impact of natural processes and material resistance on

human lives. Among these perspectives, we find actor-network theory, relational, flat and object-oriented ontologies, symmetrical perspectives, posthumanism, new materialism or the ‘material turn’. In one way or another, these are approaches that appeal to a higher sensitivity to the symmetry between humans and other kinds of physical entities in our efforts to describe and understand the world (e.g. Latour 1987, 2005; Deleuze & Guattari 2003; DeLanda 2006, 2016; Ingold 2008; Haraway 2015, 2016; Harman 2018). These perspectives have also taken inspiration from indigenous worldviews and ontologies, an intellectual inspiration that has rarely been acknowledged in the Western academic community (Marín-Aguilera 2021). These strands of thought have been fundamental in deconstructing traditional dichotomies, which have been argued to be misleading, such as human versus thing, human versus machine, human versus animal and culture versus nature. Furthermore, posthumanism and animal studies have begun to demonstrate the fallacies and inconsistencies in anthropocentric explanations for current and past processes (e.g. Weil 2012; Braidotti 2013; Fredengren 2015; Haraway 2016). How do fragmentation studies relate to these recent theoretical currents of relational archaeology?

Post-human perspectives criticise the tendency to place human agency and experience at the centre of attention, explanation and description (e.g. Fredengren 2015:125–126). In a straightforward sense, this might call into question some of the terminology and metaphors used when speaking of fragmentation in archaeology. Expressions such as ‘orphan’ shards to denote single fragments where the rest of the object is missing are one of them. Others are ‘parent’ and ‘child’ relationships for the whole and the part ‘descending’ from that whole. Although these might refer to kinship relations among animals or ‘beings’ in general, we have to raise the question about what associations these terms bring with them (intimacy, strong emotional bond, similarity). Could the fact that we are drawing from the human experience, instead of trying to describe what we see with more adapted terms, limit our view? On the other hand, in advocating more inclusive views on ‘kinship’, there are also scholars who argue for the necessity of regarding relations to landscapes, matter, objects and non-human animals as extended kinship (Johnston 2020; Brück 2021). Another relevant reflection pointed out by Emily H. Hull in her contribution to this book is the anonymising terminology and methods used to process fragmented skeletal remains from non-human animals.

A fundamental question when considering fragmentation in reference to symmetrical or relational perspectives was already touched upon in an earlier section (see *Fragmentation – definitions of an expanding concept*). How can we consider parts and wholes while also relating to reality in terms of assemblages? Seeing the world through assemblage theory stipulates that everything, all entities and even their components, are clusters forming different assemblages, more or less stable or elusive through time (e.g. DeLanda 2006,

2016; Harris 2017). Assemblages are thus, as Helen Chittock has aptly formulated by drawing on Manuel DeLanda (2006, 2016), Yannis Hamilakis and Andrew Jones (2017), “heterogeneous collections of co-functioning elements that are related but independent” (Chittock 2021:68). Moreover, as expressed by Oliver J.T. Harris (2018:89), this is “a way of thinking about the world that turns our gaze from the appearance of final, fixed forms to the multiplicity of elements that come together and sustain all the different things in the world”. As Bisserka Gaydarska (p. 104 in this volume) notes, assemblage theory thereby tells us that everything is always part of a bigger whole. Nevertheless, following Gaydarska, considering that there are designs or forms that are accepted and recognised (by humans, by animals and sometimes by other biological or physical forces in the world), these can be identified as incomplete.

In a recent analysis of the development of assemblage theory in archaeology, Yannis Hamilakis and Andrew M. Jones identify Chapman’s fragmentation theory as one of the first initiatives to have realised the significance of assemblages (Hamilakis & Jones 2017:81; see also Jones this volume; Chapman this volume). They highlight the fact that Chapman’s work not only demonstrated practices of fragmentation but also was concerned with how materials are used for creating relations, for example by discussing fragmentation and accumulation as two ways to link people through enchainment relations. Hamilakis and Jones point out the relational character of assemblages or accumulations and how these links between people, places and objects co-create relations and, essentially, reality. Relational perspectives on symmetrical relations and interdependence among all scales of assemblages are therefore in agreement with ideas concerning the ways fragments (similarly to other materials) facilitate enchainments between people, places and objects, as proposed by Chapman (2000) and developed by Chapman and Gaydarska (2007).

In his concluding essay to this volume, John Chapman points out the early contribution of fragmentation theory in shifting our thinking towards more relational perspectives on humans and their interactions/co-dependency with places and non-human animals. While still arguing for the validity of human-centred questions at the heart of the archaeological pursuit, Chapman clarifies and develops his reasoning concerning links between insights formulated in fragmentation theory and the relational perspectives that were later adopted in archaeology. Notably, he emphasises the various strategies by which people link with places and communities and how they relate to senses of belonging (where fragmentation is only one of the possible ways to do so). He shows how these insights and perspectives can be seen as an early expression of this wider orientation towards understanding not only human actors on their ‘scene’ with animal and material ‘prop’, but engaging with the network of actors and agents linking us all together.

Like fragmentation theory, assemblage theory also challenges the concept of ‘waste’ when nothing ever comes to a final form; objects, parts and atoms are part of eternal, shifting itineraries rather than linear and ending lives (Chapman & Gaydarska 2007; Harris 2018; for discussion on the problems with the concept of ‘object biography’, see, for instance, Joyce & Gillespie 2015; Jones this volume). Even if something was (subjectively/culturally) considered waste at some point, its potential for reuse and continued presence in the world as fragments makes it continue to participate in new assemblages – and perhaps eventually, in thousands of years, as microscopic fragmented grains that have joined new geological formations. This, more than before, opens up the perspective of the transformation of fragments into endless related and unrelated chains of assemblages (see Jones this volume). We believe that perceiving reality along these ontological lines does not and should not exclude an analysis of power inequalities,<sup>2</sup> injustices or potentially harmful consequences for nature or living beings resulting from the assemblages and configurations we identify. It might be true that nothing can really, ontologically or conceptually, be considered a finite ‘waste’ or an unchanging remnant of the ‘original’. Nevertheless, as scholars and citizens, we must still strive to contextualise, explain and (re)act on our observations of phenomena such as pollution or the abuse of fragments of ancient times in historical revisionism or propaganda.

### Final reflections

A central idea within studies of fragmentation is that fragments, rather than being waste or useless scrap, have special potential *precisely* because of their broken and transformed format. Through observing fragmented parts in the past and present, we reach the complex, interrelated, ever-changing assemblages that constitute our reality. In view of the stimulating observations of fragmented materials in archaeology, we see that human responses to the incomplete have often been responses of creativity, opening up new associations and allowing us to perceive other realities beyond our own. This provides insight into how fragments can be used for new purposes and processes. By asking what fragments *do*, the potential of broken material becomes more apparent and acknowledges that breaking is fundamental transformation rather than destruction or loss.

Following the itineraries of fragments included as parts of various assemblages shifting over time and scale – as part of objects, as part of bodies, as part of enchainments, as part of stratigraphic layers, as part of historical narratives, as part of museum collections, as part of clay deposits. This highlights the constant cycle of changes – the constant forming and reforming of assemblages of which our physical bodies and surroundings are part. Seeing fragmentation in this perspective also raises the question of what

fragments and assemblages we are co-creating on this planet, in the form of non-degradable chemical compounds and pieces of durable materials such as steel and plastic (e.g. Zalasiewicz et al. 2016; Pétursdóttir 2019; Kuijpers 2020). At a more fundamental level, fragmentation challenges assumptions about human independence in our era and even the fetishisation of this, and it forms part of theories that acknowledge our interdependence with ecosystems and other beings (Chapman this volume). Archaeological approaches to fragmented materials place our own practices of fragmentation and reuse in a deeper historical perspective.

### Acknowledgements

We are thankful to reviewers and colleagues for their helpful comments on earlier versions of this text. This chapter has benefited from the stimulating discussions and ideas shared at the ‘Fragmentation in Archaeological Context’ workshop that we organised in Stockholm in 2021. We want to express our sincere gratitude to the workshop participants and all contributors to this volume for their input, enthusiasm and curiosity in this endeavour.

### Notes

- 1 However, this does not mean that social personhood has always been perceived as unified; see Chapman (2000:27): “There is a common sense assumption, widespread in archaeology and anthropology, that the physically discrete nature of the body is evidence for the unity of the person. But a central paradox of the human life cycle is the contrast between the physical identity and social changes which occur and the ‘fact’ that they occur to/in the “same” person”. Here, we will not go further into the complex question of the culturally variable relationship between perception of body and the perception of personhood; but it is a topic that has been linked to the issue of fragmentation and enchainment since the first work of J. Chapman (2000; see also further discussion in Fowler 2004; Jones 2005; Brück 2006, 2017; Chapman & Gaydarska 2006; Brittain & Harris 2010).
- 2 For critique on the lack of power analysis in works of relational or symmetrical ontologies see, for instance, Harris & Cippolla 2017:148 with references.

### References

- Ahola, M. et al. 2022. Materialising the social relationships of Hunter-Gatherers: archaeological and geochemical analyses of 4th millennium BC ‘Slate Ring Ornaments’ from Finland. *Journal of Archaeological Method and Theory* 29: 1259–1293. <https://doi.org/10.1007/s10816-022-09556-8>
- Anthony, S. 2016. *Materialising modern cemeteries: archaeological narratives of Assistens cemetery, Copenhagen*. Lund: Lund University.
- Binford, L.R. 1962. Archaeology as anthropology. *American Antiquity* 28: 217–225.
- Bourguet, M.-N. et al. 1998. *L’invention scientifique de la Méditerranée: Égypte, Morée, Algérie*. Paris: Éditions de l’EHESS.
- Bradley, R. 2002. *The past in prehistoric societies*. London: Routledge.

- Bradley, R.J. & Williams, H. (eds) 1998. The past in the past: the reuse of ancient monuments. [Themed issue] *World Archaeology* 30(1).
- Braidotti, R. 2013. *The posthuman*. Cambridge: Polity Press.
- Brittain, M. & Harris, O. 2010. Enchaining arguments and fragmenting assumptions: reconsidering the fragmentation debate in archaeology. *World Archaeology* 42(4): 581–594. <https://doi.org/10.1080/00438243.2010.518415>
- Brück, J. 2006. Fragmentation, personhood and the social construction of technology in Middle and Late Bronze Age Britain. *Cambridge Archaeological Journal* 16(3): 297–315. <http://dx.doi.org/10.1017/S0959774306000187>
- . 2016. Hoards, fragmentation and exchange in the European Bronze Age. In: S. Hansen et al. (eds) *Raum, Gabe und Erinnerung: Weibgaben und Heiligtümer in prähistorischen und antiken Gesellschaften*. Berlin: Edition Topoi, 75–92.
- . 2017. Reanimating the dead: The circulation of human bone in the British Later Bronze Age. In: J. Bradbury & C. Scarre (eds) *Dealing with the dead: exploring changing human beliefs about death, mortality and the human body*, Oxford: Oxbow Books 138–148.
- . 2021. Ancient DNA, kinship and relational identities in Bronze Age Britain. *Antiquity* 95(379): 228–237. <https://doi.org/10.15184/aqy.2020.216>
- Burström, M. 2013. Fragments as something more: archaeological experience and reflection. In: A. González-Ruibal (ed.) *Reclaiming archaeology: beyond the tropes of modernity*. Milton Park, Abingdon: Routledge, 311–322.
- Callanan, M. 2012. Central Norwegian Snow Patch Archaeology: Patterns Past and Present. *Arctic* 65(1): 178–118. <https://doi.org/10.14430/arctic4192>
- . 2016. Managing frozen heritage: Some challenges and responses. *Quaternary International* 402: 72–79. <https://doi.org/10.1016/j.quaint.2015.10.067>
- Chapman, J. 2000. *Fragmentation in archaeology: people, places and broken objects in the prehistory of South Eastern Europe*. London: Routledge. <https://doi.org/10.4324/9780203759431>
- . 2022. The fragmentation of place: towards an integrated theory of fragmentation. In: M. Grygiel & P. Obst (eds) *Walking among ancient trees*. Łódź: Fundacja Badań Archeologicznych Imienia Profesora Konrada Jażdżewskiego, 635–648.
- Chapman, J. & Gaydarska, B. 2007. *Parts and wholes: fragmentation in prehistoric context*. Oxford: Oxbow.
- . 2009. The fragmentation premise in archaeology: From the Paleolithic to more recent times. In: W. Tronzo (ed.) *The Fragment: an incomplete history*. Los Angeles: Getty Research Institute, 130–153.
- Chittock, H. 2020. Pattern as patina: Iron Age ‘kintsugi’ from East Yorkshire. In: I.-M. Back Danielsson & A.M. Jones (eds) *Images in the making: art, process, archaeology*. Manchester: Manchester University Press, 149–167.
- . 2021. *Arts and crafts in Iron Age East Yorkshire: a holistic approach to pattern and purpose, c. 400 BC–AD100*. Oxford: BAR Publishing.
- Demoule, J.-P. et al. 2021. On n’échappe pas aux ruines, « c’est que l’homme s’assied où la cendre de l’homme repose ». *Perspective* 2: 19–42. <https://doi.org/10.4000/perspective.24706>
- DeLanda, M. 2006. *A new philosophy of society: assemblage theory and social complexity*. London: Continuum.
- . 2016. *Assemblage theory*. Edinburgh: Edinburgh University Press.
- Deleuze, G. & Guattari, F. 2003. *A thousand plateaus: capitalism and schizophrenia*. London: Continuum.

- Díaz-Andreu, M. 2007. *A world history of nineteenth-century archaeology. Nationalism, colonialism, and the past*. Oxford: Oxford University Press.
- Douglas, M. 1966. *Purity and danger: an analysis of concepts of pollution and taboo*. London: Routledge & K. Paul.
- Dumas-Champion, F. 1995. Destin de la tête, le culte des crânes chez les Koma du Cameroun. In: C. Baroin et al. (eds) *Morts et rites funéraires dans le bassin du lac Tchad*. Bondy: ORSTOM, 153–162.
- Fowler, C. 2004. *The archaeology of personhood: an anthropological approach*. London: Routledge.
- Fredengren, C. 2015. Nature: cultures – heritage, sustainability and feminist post-humanism. *Current Swedish Archaeology* 23: 109–130. <https://doi.org/10.37718/CSA.2015.09>
- Frieman, C. 2012. Going to pieces at the funeral: completeness and complexity in early Bronze Age jet ‘necklace’ assemblages. *Journal of Social Archaeology* 12(3): 334–355. <https://doi.org/10.1177/1469605311431400>
- Gran-Aymerich, È. 2007. *Les chercheurs de passé, 1798–1945. Aux sources de l’archéologie*. Paris: CNRS Éditions.
- Guernsey, J. 2020. *Human figuration and fragmentation in Preclassic Mesoamerica: from figurines to sculpture*. Cambridge: Cambridge University Press. <https://doi.org/10.1017/9781108782043>
- Hamilakis, J. & Jones, A.M. 2017. Archaeology and assemblage. *Cambridge Archaeological Journal* 27(1):77–84. <https://doi.org/10.1017/S0959774316000688>
- Hansen, S. 2016. A short history of fragments in hoards of the Bronze Age. In: H. Baitinger (ed.) *Materielle Kultur und Identität im Spannungsfeld zwischen Mediterraner Welt und Mitteleuropa*. Mainz: Verlag des Römisch-Germanischen Zentralmuseum, 185–208.
- Haraway, D. 2015. Anthropocene, Capitalocene, Plantationocene, Chthulucene: Making Kin. *Environmental Humanities* 6: 159–165. <https://doi.org/10.1215/22011919-3615934>
- . 2016. *Staying with the trouble: making kin in the Chthulucene*. Durham: Duke University Press.
- Harman, G. 2018. *Object-oriented ontology: a new theory of everything*. London: Pelican Books.
- Harris, O.J.T. 2017. Assemblages and scale in archaeology. *Cambridge Archaeological Journal* 27(1): 127–139. <https://doi.org/10.1017/S0959774316000597>
- . 2018. More than representation: multiscale assemblages and the Deleuzian challenge to archaeology. *History of the Human Sciences* 31(3): 83–104. <https://doi.org/10.1177/0952695117752016>
- Harris, O.J.T. & Cippolla, C.N. 2017. *Archaeological theory in the new millennium: introducing current perspectives*. Abingdon, Oxon: Routledge.
- Hicks, D. 2020. *The Brutish Museums: The Benin bronzes, colonial violence and cultural restitution*. London: Pluto Press. <https://doi.org/10.2307/j.ctv18msmcr>
- Hunter, B. & Biekert, M. 2014. *The wall for sale* [online]. *Exberliner*. <https://www.exberliner.com/berlin/fall-of-the-berlin-wall-25-years-the-wall-for-sale/>. [Accessed 5 October 2021].
- Ingold, T. 2008. Bindings against boundaries: entanglements of life in an open world. *Environment and Planning A: Economy and Space* 40(8): 1796–1810. <https://doi.org/10.1068/a40156>

- Jacob, P. L. 1859. *Curiosités de l'histoire des croyances populaires au Moyen Âge*. Paris: A. Delahays.
- Jégou, L. 2015. Compétition autour d'un cadavre. Le procès du pape Formose et ses enjeux (896-904). *Revue historique* 3(675): 499–524. <https://doi.org/10.3917/rhis.153.0499>
- Johnston, R. 2020. *Bronze age worlds: a social prehistory of Britain and Ireland*. London: Routledge. <https://doi.org/10.4324/9781315177632>
- Jones, A. 2005. Lives in fragments? Personhood and the European Neolithic. *Journal of Social Archaeology* 5(2):193–224. <https://doi.org/10.1177/1469605305053367>
- Joyce, R.A. & Gillespie, S.D. (eds) 2015. *Things in motion: object itineraries in anthropological practice*. Santa Fe, New Mexico: School for Advanced Research Press.
- Karlsson, J. 2016. *Spill : om djur, hantverk och nätverk i Mälaramrådet under vikingatid och medeltid*. Stockholm: Stockholm University.
- Kerner, J. 2018. *Manipulations post-mortem du corps humain. Implications archéologiques et anthropologiques*. Leiden: Sidestone Press.
- Kjellström, A. 2017. Tangible traces of devotion. The post-mortem life of relics. *Current Swedish Archaeology* 25: 151–175. <https://doi.org/10.37718/CSA.2017.17>
- Knight, M. 2019. Going to pieces: investigating the deliberate destruction of Late Bronze Age swords and spearheads. *Proceedings of the Prehistoric Society* 85: 251–272. <https://doi.org/10.1017/ppr.2019.3>
- . 2020. There's method in the fragments: a damage ranking system for Bronze Age metalwork. *European Journal of Archaeology* 24(1): 48–67. <https://doi.org/10.1017/ea.2020.21>
- . 2022. *Fragments of the Bronze Age: the destruction and deposition of metalwork in South-West Britain and its wider context*. Oxford: Oxbow Books.
- Knüsel, C.J. & Outram, A.K. 2004. Fragmentation: the zonation fragmented human remains and forensic contexts. *Environmental Archaeology* 9: 85–97. <https://doi.org/10.1179/env.2004.9.1.85>
- Kuijpers, M. 2020. The materials that build our world are also destroying it. What are the alternatives? [online]. *The Correspondent*. <https://thecorrespondent.com/665/the-materials-that-build-our-world-are-also-destroying-it-what-are-the-alternatives> [Accessed 8 November 2022].
- Latour, B. 1997. *Science in action: how to follow scientists and engineers through society*. Milton Keynes: Open University Press.
- . 2005. *Assembling the social: an introduction to actor-network-theory*. Oxford: Oxford University Press.
- Lémery, N. 1697. *Pharmacopée universelle, contenant toutes les compositions de pharmacie qui sont en usage dans la médecine, tant en France que par toute l'Europe*. Paris: Laurent d'Houry
- Louwen, A. 2021. *Breaking and making the ancestors: Piecing together the urnfield mortuary process in the Lower-Rhine-Basin, ca. 1300 - 400 BC*. Leiden: Sidestone Press.
- Lowenthal, D. 1989. Material Preservation and Its Alternatives. *Perspecta* 25: 67–77. <https://doi.org/10.2307/1567139>
- Lucas, G. 2005. *The archaeology of time*. London: Routledge.

- Lund, J. 2013. Fragments of a conversion: handling bodies and objects in pagan and Christian Scandinavia ad 800–1100. *World Archaeology* 45(1): 46–63. <https://doi.org/10.1080/00438243.2012.759511>
- Marín-Aguilera, Beatriz. 2021. Ceci n'est pas un subalterne. A comment on indigenuous erasure in ontology-related archaeologies. *Archaeological Dialogues* 28: 133–139. <https://doi.org/10.1017/S1380203821000234>
- Moore, H.L. 1981. Bone refuse - possibilities for the future. In: A. Sheridan & G. Bailey (eds) *Economic Archaeology*. Oxford: B.A.R., 87–94.
- Morton, S.G. et al. 2019. Shattered: Object fragmentation and social enchainment in the eastern Maya lowlands. *Journal of Anthropological Archaeology* 56: 101108. <https://doi.org/10.1016/j.jaa.2019.101108>
- Mytum, H. & Meek, J. 2021. The Iron Age in the Plastic Age: anthropocene signatures at Caseel Henllys. *Antiquity* 95(379): 198–214. <https://doi.org/10.15184/aqy.2020.237>
- Nieuwhof, A. 2020. Luxury tableware? Terra sigillata in the coastal region of the northern Netherlands. In: A. Rubel & H.-U. Voß (eds) *Experiencing the frontier and the frontier of experience*. Oxford: Archaeopress, 94–110. <https://doi.org/10.32028/9781789696813-8>
- Noterman, A. A. 2016. *Violation, pillage, profanation: La perturbation des sépultures mérovingiennes au haut Moyen Âge (VI<sup>e</sup>–VIII<sup>e</sup> siècle) dans la moitié nord de la France*. Unpublished Ph.D. dissertation, Université de Poitiers.
- Ojala, K. & Röst, A. 2021. Bronsålderns benbruk i östra Mellansverige: med exempel på variation i gravskicket vid Broby och Hallunda. *Fornvännen* 116(1): 1–16.
- Olivier, L. 2011. *The dark abyss of time: archaeology and memory*. Lanham, Md.: AltaMira Press.
- Pétursdóttir, Þ. 2019. Anticipated futures? Knowing the heritage of drift matter. *International Journal of Heritage Studies* 26(1): 87–103. <https://doi.org/10.1080/13527258.2019.1620835>
- Rebay-Salisbury, K. et al. (eds) 2010. *Body parts and bodies whole: changing relations and meanings*. Oxford: Oxbow.
- Richards, C. & Thomas, J. 1984. Ritual activity and structured deposition in Later Neolithic Wessex. In: R. Bradley & J. Gardiner (eds) *Neolithic studies: a review of some current research*. Oxford: B.A.R., 189–218.
- Rondot, V. (ed.) 2022. *Pharaon des Deux Terres : L'épopée africaine des rois de Napata*. Paris: Louvre Éditions.
- Röst, A. 2016. *Fragmenterade platser, ting och människor: stenkonstruktioner och depositioner på två gravfältlokaler i Södermanland ca 1000-300 f Kr*. Stockholm: Stockholm University.
- Schnapp, A. 2020. *Une histoire universelle des ruines. Des origines aux Lumières*. Paris: Éditions du Seuil.
- Schiffer, M.B. 1972. Archaeological context and systemic context. *American Antiquity* 37(2): 156–165. <https://doi.org/10.2307/278203>
- . 1987. *Formation processes of the archaeological record*. Albuquerque: University of New Mexico Press.
- Shefton, B. 1985. A Greek lionhead in Newcastle and Zurich. *Antiquity* 59(225): 42–44.
- Swift, E. 2012. Object biography, re-use and recycling in the late to post-Roman transition period and beyond: rings made from Romano-British bracelets. *Britannia* 43: 167–215. <https://doi.org/10.1017/S0068113X12000281>

- Thomas, L.-V. 1980. *Le cadavre: de la biologie à l'anthropologie*. Bruxelles: Éditions Complexe.
- Thrane, H. 2013. Scrap metal razors: Late Bronze Age razors made of scrap metal – another source for the study of imported bronze vessels. In: I. Heske et al. (eds) “Landschaft, Besiedlung und Siedlung”: archäologische Studien im nordeuropäischen Kontext: Festschrift für Karl-Heinz Willroth zu seinem 65. Geburtstag. Neumünster: Wachholtz, 445–453
- Thunø, E. 2018. Reliquaries and the cult of relics in late antiquity. In: R.M. Jensen & M.D. Ellison (eds) *The Routledge handbook of early Christian art*. London & New York: Routledge, 150–168.
- Tornberg, A. 2022. A prehistory of violence: Evidence of violence related skull trauma in southern Sweden, 2300-1100 BCE. In: A. Tornberg, A. Svensson, & J. Apel (eds) *Life and afterlife in the Nordic Bronze Age: Proceedings of the 15th Nordic Bronze Age Symposium held in Lund 11th to 15th June 2019*. Acta Archaeologica Lundensia Series Prima in 4; No. 37, 99–118.
- Valera, A.C. (ed.) 2019. *Fragmentation and depositions in pre and proto historic Portugal*. Lisbon: NIA-ERA.
- van der Vaart-Verschoof, S. 2017. *Fragmenting the chieftain: a practice-based study of Early Iron Age Hallstatt C elite burials in the Low Countries*. Leiden: Sidestone Press.
- Weil, K. 2012. *Thinking animals: why animal studies now?* New York: Columbia University Press.
- Westerhof, D. M. 2004. *Aristocratic executions and burials in England c. 1150 - c. 1330. Cultures of fragmentation*. Unpublished PhD dissertation. University of York.
- Williams, H. (ed.) 2011. Archaeologists on contemporary death [Themed issue]. *Mortality* 16(2). <https://doi.org/10.1080/13576275.2011.560450>
- Zalasiewicz, J. et al. 2016. The geological cycle of plastics and their use as a stratigraphic indicator of the Anthropocene. *Anthropocene* 13: 4–17. <https://dx.doi.org/10.1016/j.ancene.2016.01.002>

## **PART I**

# Fragmentation and funerary practices



# Taylor & Francis

Taylor & Francis Group

<http://taylorandfrancis.com>

# 2

## MARKING BOUNDARIES, MAKING CONNECTIONS

### Fragmenting the body in Bronze Age Britain

*Joanna Brück*

#### **Introduction**

The archaeological record is, by its very nature, a phenomenon of fragments. Taphonomic factors mean that much is lost (organics, for example), while other material culture often survives in partial or fragmentary form. It has been easy to assume that post-depositional processes are the primary drivers of fragmentation in the archaeological record. Although Schiffer's classic work on formation processes considered both natural and cultural factors in the transformation of sites and artefacts (Schiffer 1987), only since John Chapman's seminal research (Chapman 2000; Chapman & Gaydarska 2007) has the role of the fragmentation of artefacts as a deliberate cultural practice come to be more widely considered.

Of course, artefacts are not the only things that survive in fragmentary form in the archaeological record. Human bodies are also fragmented through a variety of cultural and natural processes, and stray pieces of human bone are not unusual finds on archaeological sites, even those of a non-funerary nature. Such finds are often assumed to result from the accidental disturbance of primary inhumation burials and subsequent unintentional reincorporation into later depositional contexts. In recent years, however, archaeologists have explored how the complex and protracted nature of funerary rites means that mortuary practices can themselves lead to the fragmentation of the body (e.g. Rebay-Salisbury et al. 2010; Weiss-Krejci 2010; Noterman this volume). Processes such as excarnation, for example, can result in the swift skeletonisation and disarticulation of the body after death. Secondary burial has also been commonly documented (e.g. Schmitt et al. 2018): temporary places of burial can be reopened and bones removed for final deposition elsewhere.

The various factors that can result in the fragmentation and loss of bone during and after cremation have also been discussed (McKinley 1989; Louwen this volume). Moreover, individual human bones can also be retained and circulated outside of the funerary context for different reasons. The potential of the dead to be drawn into the social and political strategies of the living has been the subject of many studies (e.g. Verdery 1999; Weiss-Krejci 2011).

In BA Britain (c. 2500–800 BCE), disarticulated fragments of human bone are commonly recovered from a variety of mortuary and non-mortuary contexts, and these often appear to have been deliberately selected for deposition. This paper will bring together a variety of evidence to consider the social practices that resulted in the fragmentation of the body during this period. We will examine differences in the treatment and deposition of such finds over the BA, which suggest that the meaning ascribed to the process of fragmentation changed. The significance of such practices for changing perceptions of the body and personhood and for the social role of the dead in the world of the living will also be considered. Moreover, the deliberate fragmentation of human bodies has interesting implications for our understanding of other broken objects. At present, two competing conceptual frameworks are applied to broken artefacts in the BA. Broken ceramics, for example, are frequently viewed as refuse, while the presence of broken bronze objects in hoards has often been interpreted as a means of commodification – a way of stripping the social value from artefacts so that they could be weighed and measured for the purposes of trade (e.g. Bradley 1985; Huth 1997). Others view the deliberate breakage of artefacts as an act of enchainment that underlines their ongoing social salience. For example, it has been argued that the deliberate fragmentation of grave goods from Early Bronze Age (EBA) burials helped to map and maintain connections between the living and the dead, creating heirlooms that could be retained and transmitted across the generations (e.g. Sheridan & Davis 2002; Woodward & Hunter 2015). These competing interpretations are based on quite different understandings of the relationship between people and objects. Here, I will explore the practices of fragmentation applied to human remains in BA Britain to consider these questions afresh.

### **Fragmented bodies in Bronze Age graves**

Historically, fragments of human bone found in both mortuary and non-mortuary contexts have often been explained away as accidental inclusions. For example, at Redlands Farm, Irthlingborough, Northamptonshire, the inhumation burial of an adult female dating to the EBA was accompanied by a shale armband, a copper-alloy earring, two flint flakes and a Beaker pot (Bradley 2007:167–169). The grave also yielded two incisors, a skull fragment, a possible pelvis fragment from a second adult and a humerus fragment

from a subadult. The published plan of the grave shows only the inhumation burial and the artefacts, suggesting that the excavators considered the other fragments of human bone to be accidental inclusions, although there is no explicit discussion of this question in the excavation report. This reluctance to consider fragments of bone as possible grave goods may be a product of our own tendency to classify people and objects as distinct cultural categories. However, as we will discuss below, this view may not have been shared by those who buried the dead in the BA.

Sometimes the evidence of complex mortuary practices that resulted in the fragmentation of the body and deliberate (re)deposition of those fragments is incontrovertible, however. At Dryburn Bridge in East Lothian, two neighbouring stone cists of EBA date each contained the well-preserved crouched inhumation of an adult male (Dunwell 2007). Lying over the pelvis and abdomen of the burial in cist 1 were the disarticulated remains of another adult male, whereas in cist 2, the disarticulated bones of a child were deposited over the feet and lower legs of the articulated inhumation (Figure 2.1). Both disarticulated bodies were incomplete: most of the larger bones were present, but despite the good condition of the bones, the smaller bones of the hands and feet were underrepresented. This suggests that the cists had never contained the complete bodies of the disarticulated adult and child and that their bones had been brought from elsewhere for redeposition; the location of the missing elements remains unknown.

The presence of disarticulated and fragmentary bones in British BA mortuary contexts is, in fact, not unusual (e.g. Gibson 2004; Fowler 2013:108–169). Although the dominant image of BA burials is of single burials of complete bodies shortly after death, the evidence suggests a more complex and variable picture (as is the case in other regions too, e.g. Chapman 2010). Bodies are often incomplete. In many cases, this is because graves were reopened, sometimes to deposit additional bodies but also to encounter, handle and remove the bones of the dead. At Babraham Road in Cambridge, for example, a grave containing the partially articulated and incomplete remains of a young adult male was found (Hinman & Malim 1999). Articulated elements included the right arm, which was still attached to the ribcage, although the hand was missing. The mandible had been placed on a pile of partially articulated foot bones just below the pelvis. A cutmark ‘visible where the jaw joined with the skull’ may have been made when the mandible was detached; this suggests that the grave was reopened and the bones rearranged (and probably removed) when the body was in a partially decomposed state. At South Dumpton Down in Kent, three deep intercutting pits at the centre of a ring ditch contained seven crouched inhumations deposited in sequence (Perkins 1995). Most of the skulls were missing, suggesting that each time a new body was interred, the skull of the preceding burial was removed. Another nearby grave may provide a clue as to what happened to those missing bones.

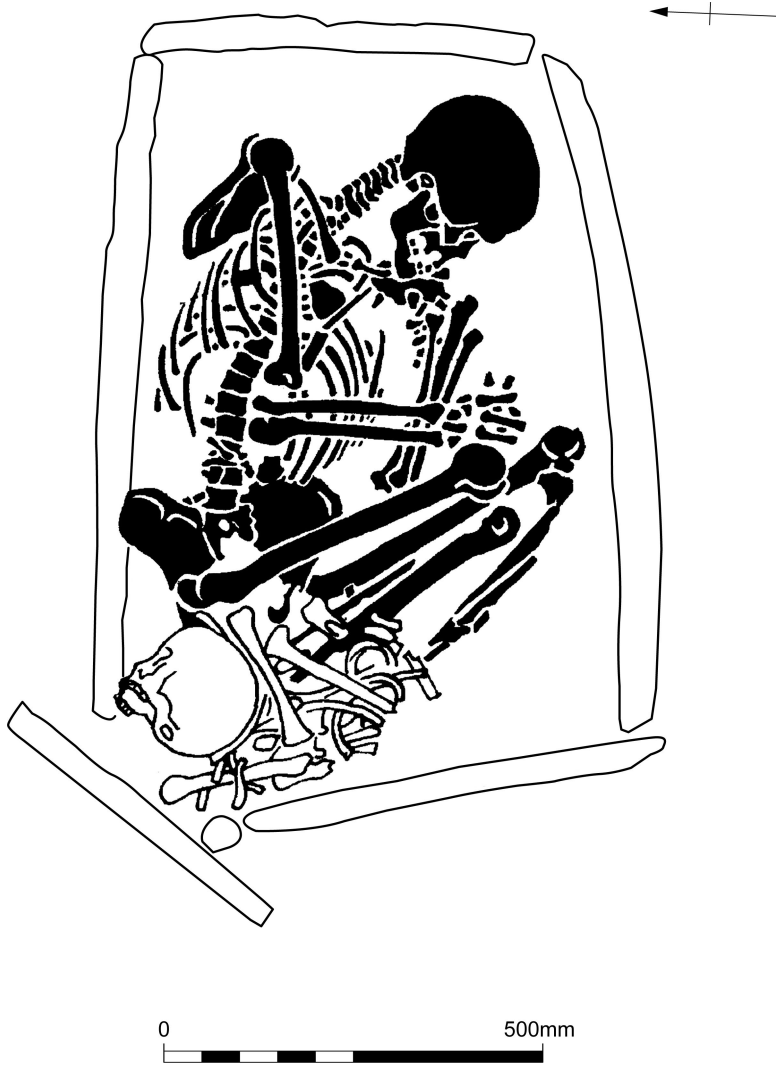

**FIGURE 2.1** Cist 2 at Dryburn Bridge, East Lothian (reproduced with permission of Dave Pollock, Andrew Dunwell, and the Society of Antiquaries of Scotland).

This contained two complete articulated inhumation burials, one of which was accompanied by the disarticulated mandible of a third individual.

The reopening of existing primary graves was not the only way in which the bodies of the dead were fragmented and dispersed. Recent analysis suggests that exhumation may also have been practiced during this period. At Melton Quarry in East Yorkshire, the disarticulated and incomplete remains

of an infant were found nestled between the torso and legs of a complete crouched inhumation burial (Fraser Brown and Lauren McIntyre, Oxford Archaeology South, pers. comm.). Radiocarbon dating indicated that these bones were between 185 and 346 years older (at 68% confidence) than the inhumation burial (Brück & Booth 2022a). Histological analysis of the infant's bone shows low levels of bacterial attack on the internal bone microstructure, contrasting with a bone sample from the accompanying articulated skeleton, which showed extensive bacterial bioerosion (Brück & Booth 2022a). Previous studies indicate that bodies buried intact and soon after death in generally dry, aerobic environments will suffer high levels of bacterial bioerosion to the internal bone microstructure visible through micro-CT analysis (Jans et al. 2004; Booth 2016). By contrast, low levels of bacterial bioerosion are the result of post-mortem treatments that inhibit bodily decomposition, such as mummification or deposition in waterlogged environments, or that rapidly remove soft tissue, such as excarnation and dismemberment (Booth et al. 2015; Booth 2016). The disarticulated state of the infant's bones from Melton suggests that the body may originally have been excarnated. Collections of objects probably deposited in organic bags are a common feature of EBA burials (Cooper et al. 2019), and it is possible that these bones were kept in such a container, perhaps even worn on the body of the articulated individual during life.

Some of the bones from Windmill Fields in Ingleby Barwick, North Yorkshire, were probably also retrieved from bodies that had been excarnated. At this site, the inhumation burial of an adult female was accompanied by a bundle of disarticulated skulls and long bones representing at least three other individuals (Annis et al. 1997). Radiocarbon dating of two of the skulls (one adult male and one adult female) indicates that they were between 59 and 179 years older (at 68% confidence) than the articulated burial (Brück & Booth 2022a). A nearby pit yielded an assemblage of partial and disarticulated remains. Histological analysis of a disarticulated long bone from this second deposit revealed little bioerosion, consistent with the body having been excarnated (Booth et al. 2015:1167). Radiocarbon dating indicates that the two skulls that accompanied the female inhumation are contemporary with the deposit of disarticulated remains in the neighbouring pit (Booth et al. 2015:1197), and they may have been retrieved from that deposit.

The manipulation and curation of disarticulated bones and their (re)deposition as 'grave goods' in subsequent burials call into question the relationship between bodies and objects. It is perhaps therefore unsurprising that a small number of artefacts made from human bone have been found in burials of EBA date. The primary cremation in Wilsford Barrow G15 in Wiltshire, for example, was accompanied by a belt hook made from a human femur (Figure 2.2) (Woodward & Hunter 2015: Table 3.3.1, 200). Nearby, the



**FIGURE 2.2** The belt hook of human bone from Wilsford Barrow G15, Wiltshire (© Wiltshire Museum).

inhumation burial of an adult male in barrow G58 yielded a bone tube fashioned from a human femur (Woodward & Needham 2012; Woodward & Hunter 2015:114). The interior of this item has been scraped out and its outer surface polished. There originally appears to have been a hole towards one end of the tube, although this no longer survives; the item has therefore sometimes been described in the literature as a whistle, although that interpretation remains uncertain. Although its significance is hard to interpret, the selection of a human femur for both the whistle and the belt hook is interesting. Such powerful acts of enchainment linked dead members of the community with objects that might themselves have been viewed as imbued with life force.

The intimacy of the physical connections between bodies and body parts in BA graves suggests close social relations. Previous work on EBA grave goods suggests that some objects were already old on deposition, and these have been interpreted as heirlooms (e.g. Sheridan & Davis 2002; Woodward & Hunter 2015). In a similar way, we can suggest that both unmodified human bones and artefacts fashioned from them were viewed as ancestral relics. The suggestion that curated bones belonged to important ancestors is perhaps supported by the aDNA evidence from the grave of the so-called Boscombe Bowmen in Wiltshire. This grave contained the articulated and disarticulated

remains of several adults and children (McKinley 2011). At the base of the grave lay the inhumation burial of an adult male. A bundle of disarticulated bones was found under his body, and two crania and part of a mandible lay at his feet. Genetic analysis of the inhumation burial and one of the crania indicated that the disarticulated skull came from a second- to third-degree relative of the articulated male (Olalde et al. 2018; Booth et al. 2021), possibly a genetic paternal cousin, half-sibling, (great) uncle, or (great) grandfather of the articulated male. This suggests that disarticulated remains at least sometimes belonged to genetic relatives of the primary burials in which they were deposited. Strontium isotope analysis of enamel in teeth from the articulated male and the cranium suggests that these two individuals undertook similar journeys in childhood (Evans et al. 2006). The decision to redeposit the skull alongside an articulated body that had a similar life history suggests that the identity of the individual to whom the skull belonged was known and remembered.

The suggestion that fragmentary and disarticulated remains belonged to specific known kin rather than generalised ancestors is supported by radiocarbon dating. A recent study of curated remains from British EBA mortuary contexts employed statistical analysis to demonstrate that the median period of curation for disarticulated fragments of bone is 95 years, around three to four generations (Brück & Booth 2022a). Jan Assmann's useful distinction between communicative and cultural memory can help us make sense of this pattern (Assmann 2008). Communicative memory can be characterised as living memory, transmitted through everyday interpersonal interaction. In contrast, cultural memory is a form of collective memory, enshrined in myth, ritual and tradition. Communicative memory, Assmann suggests, can be maintained for around 80–100 years, or three to four generations, matching well the average period of curation for disarticulated bone from EBA graves.

### **Fragmented bodies in non-mortuary contexts**

The examples discussed thus far are all from EBA graves. In contrast, during the Late Bronze Age (LBA, c. 1150–800 BCE), mortuary rites were largely archaeologically invisible, and we know little about how the dead were treated. Instead, fragments of unburned, disarticulated bone and small deposits of cremated remains are frequently recovered from LBA settlements and other non-mortuary contexts (Brück 1995). At Shorncote Quarry in Gloucestershire, for example, part of an unburned human skull was found in the basal fills of a waterhole that formed part of an extensive open settlement (Boyle 2002:69). The extraordinarily well-preserved settlement at Must Farm in Cambridgeshire has produced several fragments of human bone (Dodwell, in press), including a near-complete skull found in a midden adjoining one of the roundhouses. Osteological analysis identified peri-mortem or

post-mortem trauma to its base, indicative either of decapitation or possibly modification so that it could be placed on a flat surface for display. The polished appearance of the skull suggests it was touched or handled repeatedly, although radiocarbon dating indicates that it was deposited in the midden only a few years after death.

In LBA Britain, fragments of human bone were often deposited at boundaries and entrances (Brück 1995). At South Hornchurch, London Borough of Havering (Guttmann et al. 2000), a small deposit of cremated human bone was recovered from one of the postholes in the porched entranceway to a roundhouse. Elsewhere on the same site, the entrances to a large ringwork (a characteristic type of monumental settlement enclosure) were marked in a similar way: a deposit of cremated bone was found in a pit just outside the southern entrance to the enclosure, while fragments of burned bone were also placed in the northern terminal of the ditch at the north-eastern entrance. Human bone is also commonly encountered in other features across the settled landscape, such as field boundaries, burnt mounds and waterholes. Like the entrances to roundhouses and settlements, many of these locations can be viewed as liminal places – meeting points between different worlds at which productive and dangerous transformations might take place. At Bradley Fen in Cambridgeshire, for example, the junction between the fen and the higher ground to the east became a focus for deposition (Knight & Brudenell 2020:180–188). A hoard of broken fragments of swords, spearheads, ferrules and chapes was deposited in the watery fen edge where two field boundaries met (Figure 2.3). In the peat, c. 5m north of the hoard, were three fragments of human skulls. Histological analysis suggests that the body to which these originally belonged may have been excarnated (Brück & Booth 2022b).

Lengthy and complex post-mortem trajectories are suggested by evidence for the working or modification of human bone from several LBA sites. Cutmarks were identified on three skull fragments from Stanton St Bernard (Wiltshire), for example; in this instance, modification of the bone appears to have been carried out on already disarticulated remains (D. McOmish, pers. comm.). All three fragments were weathered, suggesting that they were exposed to the elements, perhaps during excarnation or display. At Potterne in Wiltshire, a mandible fragment and a skull fragment had been cut into roughly rectangular shapes that would fit in the palm of a hand (Waddington 2009:328, 333). Radiocarbon dating indicated that the mandible fragment had been curated for between 210 and 96 years prior to deposition (at 68% confidence; Brück & Booth 2022b); in contrast, for the skull fragment, the date of death and date of deposition were not significantly different.

Complex forms of post-mortem interaction with the bodies of the dead in LBA Britain are perhaps most vividly demonstrated by the large pit at Cliffs End Farm in Kent, which yielded an extraordinary variety of articulated, semi-articulated and disarticulated human remains (McKinley et al. 2015). These included the articulated but incomplete body of an adult male, comprising

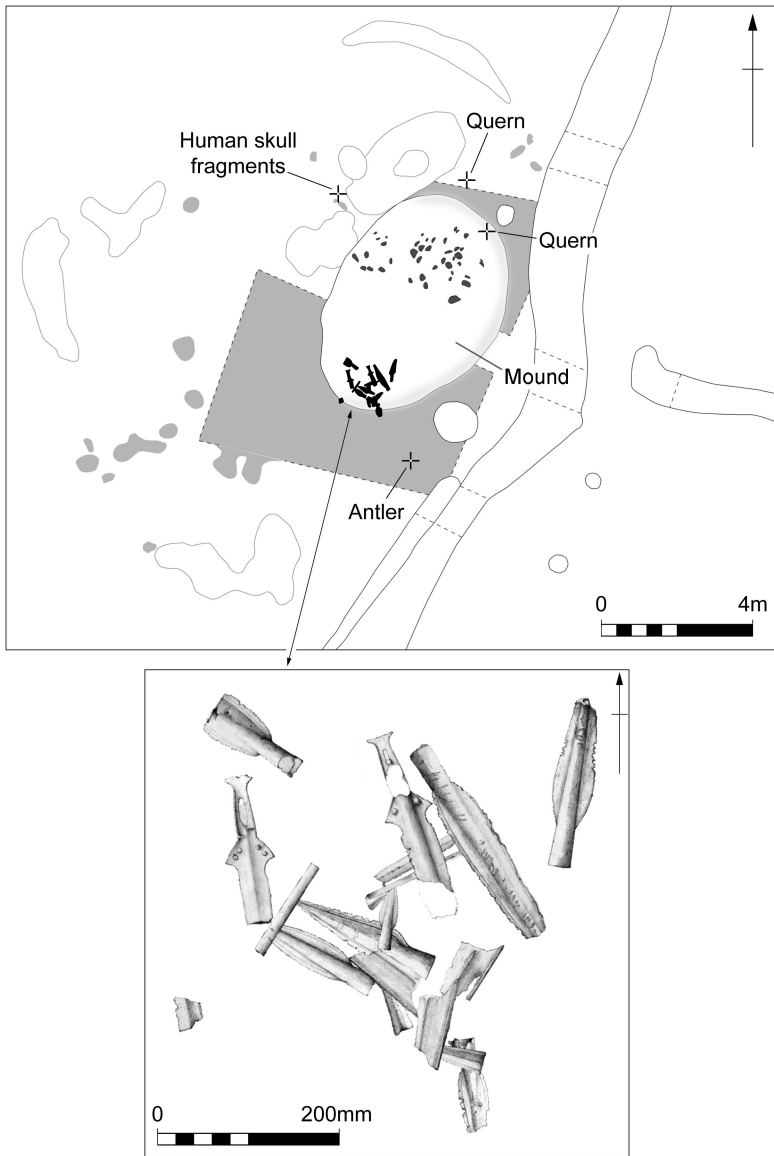

**FIGURE 2.3** The hoard, human bone and other finds from the fen edge at Bradley Fen, Cambridgeshire (reproduced with permission of Cambridge Archaeological Unit).

the skull, spine, left half of the ribcage and upper left arm arranged as a bundle; the awkward relative positioning of the different elements suggested that the body must have been partially decomposed when it was deposited in the pit. Other finds from the pit included the crouched and prone body of a 10–11-year-old child, which was missing its right hand and most of its skull. The body of a second child of around the same age was laid in a tightly crouched position on its right-hand side; its skull had been twisted round to face half of a ceramic vessel deposited behind the head, probably once the body had partially decomposed. There is no evidence for re-excavation of the feature between episodes of deposition, and the excavators suggest that the pit was left open for a number of years to facilitate the addition of bodies and manipulation of existing deposits. The presence of articulated remains suggests that there may have been a temporary cover to protect the bodies from the elements and from scavengers. However, evidence for canid gnawing and weathering on some of the disarticulated bones from the pit hints that these may have been retrieved from elsewhere for redeposition.

Although the shaped mandible fragment from Potterne described above may have been kept for up to two centuries, most disarticulated bones from LBA contexts were not curated for such long periods of time. An analysis of radiocarbon dates was able to demonstrate a statistically significant difference between the date of death and the date of deposition for just 20% of such fragments (Brück & Booth 2022b). This contrasts with the evidence from EBA graves, where more than 50% of dated disarticulated remains were older than their final depositional context. The median period of curation is also different. As we have already noted above, disarticulated bones from EBA graves have been curated for an average of 95 years. In contrast, the median period of curation for fragments of bone from non-mortuary contexts of LBA date was 43 years.

How might this difference be explained? One clue is perhaps provided by the identification of evidence of violence. This is present, although relatively rare, in the EBA (Thorpe 2006). In contrast, evidence for sharp-force trauma is more common in the LBA. For example, a skull fragment from East Chisenbury in Wiltshire displayed injuries inflicted by a pointed implement or weapon around the time of death or shortly thereafter (Egging Dinwiddy 2021). A probable blade injury was identified on a fragment of frontal bone belonging to an adult male deposited at the base of a pit dating to the LBA–Early Iron Age transition at Eye Quarry, Cambridgeshire (Dodwell 2009). It is therefore possible that some disarticulated bones from LBA contexts belonged to enemies rather than ancestors, and this may explain why they were not curated for such long periods. The fragmentation of bodies and the deposition of those fragments soon after death may have been a way of negating the personhood of the deceased. The frequent deposition of human bone in liminal contexts – places of danger where social categories could

be challenged and dissolved – may support this suggestion. Such a practice would, of course, affect the median period of curation, although other bones may have been curated and displayed as trophies over longer periods of time.

This interpretation should not be taken too far, however. No detailed study of the cutmarks on LBA human bone has yet been carried out, and it is often unclear if these were the result of post-mortem manipulation or peri-mortem violence. In the modern Western world, the dissolution of the human body is frequently viewed with disgust and disquiet due to the ideological primacy of concepts of the self as a bounded individual (Morris 1991). It is easy to inadvertently impose such assumptions onto the past by viewing fragments of human bone as a manifestation of the abject (Kristeva 1982), a deliberate negation of culturally prescribed concepts of the self. In fact, the recovery of human bone from in and around houses and the evidence for the manipulation of skeletonised and semi-decomposed bodies suggest that LBA people may have been accustomed to handling the remains of the dead and might not have viewed these in a negative way. Yet, anthropological studies suggest that in many societies, processes of transformation involving transition from one state to another or the crossing of social boundaries can be viewed as both dangerous and productive (Douglas 1966; Bloch & Parry 1982). The deposition of human bone in liminal contexts (such as the entrances to settlements or wetlands) may therefore suggest an element of ambivalence in how the remains of the dead were understood in the LBA. Fragments of human bone were deposited not because they were rubbish, accidentally incorporated into such contexts, but because bone was a powerful and meaningful material.

## Conclusion

In this paper, I have suggested that throughout the British BA, human bodies were deliberately fragmented, either in the context of protracted funerary rites or because bones were required for social and political purposes beyond the mortuary domain. However, it is possible to suggest that the meaning of fragmentation as a process changed. In the EBA, fragmentation of bone facilitated the curation, circulation and redeposition of ancestral remains, mapping the location of people within webs of kinship and giving material form to significant interpersonal relationships. These were the familiar dead, and often their specific identities may have been known. In the future, the potential of aDNA to facilitate the tracking of fragmented individuals might help to illuminate further the links between the living and the dead. In the LBA, on the other hand, disarticulated human bones are found not in graves but in quite different archaeological contexts. Sometimes, fragmentation of the bodies of enemies may have been a means of negating (or at least reconfiguring) their identities, but disarticulated human remains were not necessarily stripped of value or meaning. The deposition of fragments of bone in liminal places suggests that it

was viewed as ambivalent and dangerous, but it was also a powerful material that conjured productive and necessary processes of transformation. Whether it was a relic belonging to an ancestor or the skull of an enemy, human bone had an important social and political role. As yet, there has been no sustained study of evidence for the cutting, shaping or polishing of human bone in the British LBA, even though there is currently little understanding of how those modifications came about. In the future, such work has considerable potential to help us understand the complexities of these practices.

The examples discussed in this paper suggest that no single interpretation can be applied to the act of bodily fragmentation or to the deliberate circulation, re-use and deposition of fragments of bone in BA Britain. Of course, the practice and meaning of fragmentation are also likely to have varied in other chronological and geographical contexts; fragmenting the body facilitated a variety of ways of making and breaking relationships. What, then, are the implications of these observations for other fragmented objects in the BA, both in Britain and beyond? Bronze hoards frequently include broken artefacts, but this was not always a means of commodifying the metal from which they were made or, necessarily, of cutting them off from their histories. For example, the Middle BA hoard of 79 artefacts deposited in a ceramic vessel near Lewes in East Sussex (Portable Antiquities Scheme SUSS-C5D042) includes both complete and broken bronze ornaments. Some, like the ‘Sussex loop’ bracelets and finger rings, were complete or largely complete, whereas the quoit-headed pins, torcs and coiled spiral necklaces were deposited mostly as fragments. Objects of other materials were also found, including a number of amber beads and four gold discs. It is hard to see the assembly and deposition of this collection of objects as the result of ‘economic’ imperatives such as recycling or trade. Instead, we can suggest that the histories of these objects were known and that their links with the biographies of particular people were significant. Like human bones, hoards too were deposited in liminal places. For example, the hoard from Isleham in Cambridgeshire, including fragments of weapons, bronze vessels and horse gear, was deposited near the terminal of a ditch, probably part of a field boundary that ran down to the fen edge (Malim et al. 2010). In light of our discussion of the deposition of human bone above, we can suggest that broken objects (each with its own biography) in so-called scrap hoards were not commodities but powerful social agents whose fragmentation facilitated the reformulation of relational identities. The deposition of *pars pro toto* offerings marked and mediated the crossing of boundaries, making possible the recycling of objects with histories, and acknowledging the challenges and potential of social and material change (see Fontijn 2019).

In BA Britain, then, deliberate fragmentation of both bodies and objects was a socially significant act. On the one hand, it was an act of enchainment, designed to mark and maintain particular relationships through the curation,

exchange and deposition of fragments of meaningful things, at least some of which had known histories. On the other hand, it also facilitated the transgression of cultural categories and processes of transformation integral to the renewal of life (Brück 2006). Its meaning appears to have changed over the course of the period, so that fragments of human bone and broken artefacts may have been viewed with a certain level of ambivalence by the LBA. This may be a reflection of wider processes of change, notably the increasing intensity and frequency of inter-community engagement as suggested by the extensive evidence for the movement of people, materials and objects during this period (e.g. Needham et al. 2013; Patterson et al. 2021).

## References

- Annis, R. et al. 1997. *An unusual group of Early Bronze Age burials from Windmill Fields, Ingleby Barwick, Stockton-on-Tees*. Hartlepool: Tees Archaeology unpublished report.
- Assmann, J. 2008. Communicative and cultural Memory. In: A. Erll & A. Nünning (eds) *Cultural memory studies. An international and interdisciplinary handbook*. Berlin: De Gruyter, 109–118. <https://doi.org/10.1515/9783110207262.2.109>.
- Bloch, M. & Parry, J. 1982. Introduction: death and the regeneration of life. In: M. Bloch & J. Parry (eds) *Death and the regeneration of life*. Cambridge: Cambridge University Press, 1–44. <https://doi.org/10.1017/CBO9780511607646.002>.
- Booth, T.J. 2016. An investigation into the relationship between funerary treatment and bacterial bioerosion in European archaeological human bone. *Archaeometry* 58: 484–499. <https://doi.org/10.1111/arcm.12190>.
- Booth, T.J. et al. 2015. Mummification in Bronze Age Britain. *Antiquity* 89: 1155–1173. <https://doi.org/10.15184/aqy.2015.111>.
- Booth, T.J. et al. 2021. Tales from the supplementary information: ancestry change in Chalcolithic and Early Bronze Age Britain. *Cambridge Archaeological Journal* 31: 379–400. <https://doi.org/10.1017/S0959774321000019>.
- Boyle, A. 2002. Human bone. In: A. Brossler. Shorncliffe Quarry: excavations of a late prehistoric landscape in the Upper Thames Valley, 1997 and 1998. *Transactions of the Bristol and Gloucestershire Archaeological Society* 120: 68–70.
- Bradley, P. 2007. The long barrow. In: J. Harding & F. Healy (eds) *The Raunds area project. A Neolithic and Bronze Age landscape in Northamptonshire*. London: English Heritage, 166–169. <https://doi.org/10.2307/j.ctvxc8r1.12>.
- Bradley, R. 1985. Exchange and social distance: the structure of bronze artefact distributions. *Man* 20: 692–704. <https://doi.org/10.2307/2802757>.
- Brück, J. 1995. A place for the dead: the role of human remains in Late Bronze Age Britain. *Proceedings of the Prehistoric Society* 61: 245–277. <https://doi.org/10.1017/S0079497X00003091>.
- . 2006. Fragmentation, personhood and the social construction of technology in Middle and Late Bronze Age Britain. *Cambridge Archaeological Journal* 16(2): 297–315.
- Brück, J. & Booth, T. 2022a. The power of relics: the curation of human bone in British Bronze Age burials. *European Journal of Archaeology* 25(4): 440–62. <https://doi.org/10.1017/eea.2022.18>.

- . 2022b. The ambivalent dead: curation, excarnation and complex post-mortem trajectories in Middle and Late Bronze Age Britain. *Proceedings of the Prehistoric Society* 88: 193–220. <https://doi.org/10.1017/ppr.2022.8>.
- Chapman, J. 2000. *Fragmentation in archaeology: people, places and broken objects in the prehistory of South Eastern Europe*. London: Routledge. <https://doi.org/10.4324/9780203759431>
- . 2010 ‘Deviant’ burials in the neolithic and chalcolithic of central and south eastern Europe. In: K. Rebay-Salisbury et al. (eds) *Body parts and bodies whole: changing relations and meanings*. Oxford: Oxbow Books, 30–45.
- Chapman, J. & Gaydarska, B. 2007. *Parts and wholes. Fragmentation in prehistoric context*. Oxford: Oxbow Books.
- Cooper, A. et al. 2019. Covering the dead in later prehistoric Britain: elusive objects and powerful technologies of funerary performance. *Proceedings of the Prehistoric Society* 85: 223–250. <https://doi.org/10.1017/ppr.2019.8>.
- Dodwell, N. 2009. Assessment of the human bone. In: R. Patten. Excavations at Eye Quarry the southern extension. *CAU Unpublished Report* 869: 82–84.
- Dodwell, N. In press. Human bone. In: M. Knight et al. (eds) *The Must Farm pile-dwelling settlement. Volume 2: specialist reports*. Cambridge: McDonald Institute for Archaeological Research, chapter 25.
- Douglas, M. 1966. *Purity and danger: an analysis of the concepts of pollution and taboo*. London: Routledge & Kegan Paul.
- Dunwell, A. 2007. *Cist burials and an Iron Age settlement at Dryburn Bridge, Innerwick, East Lothian*. Edinburgh: Society of Antiquaries of Scotland.
- Egging Dinwiddy, K. 2021. Human bone. In: P. Andrews. East Chisenbury Midden 2015–17: further investigations of the late prehistoric midden deposits, enclosure and associated settlement. *Wiltshire Archaeological and Natural History Magazine* 114: 102–103.
- Evans, J. et al. 2006. Bronze Age childhood migration of individuals near Stonehenge, revealed by strontium and oxygen isotope tooth enamel analysis. *Archaeometry* 48: 309–321. <https://doi.org/10.1111/j.1475-4754.2006.00258.x>.
- Fontijn, D. 2019. *Economies of destruction: how the systematic destruction of valuables created value in Bronze Age Europe, c. 2300–500 BC*. London: Routledge. <https://doi.org/10.4324/9781315109879>.
- Fowler, C. 2013. *The emergent past: a relational realist archaeology of Early Bronze Age mortuary practices*. Oxford: Oxford University Press. <https://doi.org/10.1093/acprof:osobl/9780199656370.001.0001>.
- Gibson, A. 2004. Burials and beakers: seeing beneath the veneer in Late Neolithic Britain. In: J. Czebreszuk (ed.) *Similar but different: Bell Beakers in Europe*. Poznan: Adam Mickiewicz University, 173–192.
- Guttmann, E. et al. 2000. A Late Bronze Age landscape at South Hornchurch, Essex. *Proceedings of the Prehistoric Society* 66: 319–359. <https://doi.org/10.1017/S0079497X00001845>.
- Hinman, M. & Malim, T. 1999. Ritual activity at the foot of the Gog Magog Hills, Cambridge. *Past* 31: 1–3.
- Huth, C. 1997. *Westeuropäische Horte der Spätbronzezeit*. Regensburg: Universitätsverlag.
- Jans, M. et al. 2004. Characterisation of microbial attack on archaeological bone. *Journal of Archaeological Science* 31: 87–95. <https://doi.org/10.1016/j.jas.2003.07.007>.

- Knight, M. & Brudenell, M. 2020. *Pattern and process. Landscape prehistories from Whittlesey Brick Pits: the King's Dyke & Bradley Fen excavations 1998–2004*. Cambridge: McDonald Institute for Archaeological Research. <https://doi.org/10.17863/CAM.55585>.
- Kristeva, J. 1982. *Powers of horror: an essay on abjection*, trans. Léon S. Roudiez. New York: Columbia University Press.
- Malim, T. et al. 2010. The environmental and social context of the Isleham hoard. *Antiquaries Journal* 90: 73–130. <https://doi.org/10.1017/S0003581509990485>.
- McKinley, J. 1989. Cremations: expectations, methodologies and realities. In: C.A. Roberts et al. (eds) *Burial archaeology: current research, methods and developments*. Oxford: BAR, 65–76.
- . 2011. Human remains. In: A. Fitzpatrick. *The Amesbury Archer and the Boscombe Bowmen. Bell Beaker Burials at Boscombe Down, Amesbury, Wiltshire. Wessex Archaeology*: 18–32.
- McKinley, J. et al. 2015. *Cliffs End Farm, Isle of Thanet, Kent: a mortuary and ritual site of the Bronze Age, Iron Age and Anglo-Saxon period with evidence for long-distance maritime mobility*. Salisbury: Wessex Archaeology Reports 31.
- Morris, B. 1991. *Western conceptions of the individual*. London: Berg.
- Needham, S. et al. 2013. *Claimed by the sea: Salcombe, Langdon Bay and other marine finds of the Bronze Age*. York: Council for British Archaeology.
- Olalde, I. et al. 2018. The Beaker phenomenon and the genomic transformation of northwest Europe. *Nature* 555: 190–196. <https://doi.org/10.1038/nature25738>.
- Patterson, N. et al. 2021. Large-scale migration into Britain during the Middle to Late Bronze Age. *Nature*. <https://doi.org/10.1038/s41586-021-04287-4>.
- Perkins, D. 1995. *An assessment/research design: South Dumpton Down, Broadstairs*. Canterbury: Trust for Thanet Archaeology unpublished report.
- Rebay-Salisbury, K. et al. (eds) 2010. *Body parts and bodies whole: changing relations and meanings*. Oxford: Oxbow Books.
- Schiffer, M. 1987. *Formation processes of the archaeological record*. Albuquerque: University of New Mexico Press.
- Schmitt, A. et al. (eds) 2018. *Gathered in death. Archaeological and ethnological perspectives on collective burial and social organisation*. Louvain-la-Neuve: Presses Universitaires de Louvain.
- Sheridan A. & Davis M. 2002. Investigating jet and jet-like artefacts from prehistoric Scotland: The National Museums of Scotland project. *Antiquity* 76: 812–825. <https://doi.org/10.1017/S0003598X00091298>.
- Thorpe, I.J.N. 2006. Fighting and feuding in Neolithic and Bronze Age Britain and Ireland. In: T. Otto et al. (eds) *Warfare and society. Archaeological and social anthropological perspectives*. Aarhus: Aarhus University Press, 141–166.
- Verdery, K. 1999. *The political lives of dead bodies: reburial and postsocialist change*. New York: Columbia University Press.
- Waddington, K. 2009. *Re-assembling the Bronze Age: exploring the southern British midden sites*. Unpublished Ph.D. thesis, Cardiff University.
- Weiss-Krejci, E. 2010. The formation of mortuary deposits: implications for understanding mortuary behavior of past populations. In: S. Agarwal & B. Glen-cross (eds) *Social bioarchaeology*. Oxford: Blackwell, 68–106. <https://doi.org/10.1002/9781444390537.ch4>.

- . 2011. The role of dead bodies in Ancient Maya politics: cross-cultural reflections on the meaning of Tikal altar 5. In: J. Fitzsimmons & I. Shimada (eds) *Living with the dead: mortuary ritual in Mesoamerica*. Tuscon: University of Arizona Press, 17–51.
- Woodward, A. & Hunter, J. 2015. *Ritual in Early Bronze Age grave goods: an examination of ritual and dress equipment from Chalcolithic and Early Bronze Age graves in England*. Oxford: Oxbow.
- Woodward, A. & Needham, S. 2012. Diversity and distinction: characterising the individual buried at Wilsford G58, Wiltshire. In Jones, A.M. et al. (eds) *Image, memory and monumentality: archaeological engagements with the material world*. Oxford: Prehistoric Society/Oxbow, 116–126.

# 3

## BREAKING AND MAKING THE ANCESTORS. FRAGMENTATION AS A KEY FUNERARY PRACTICE IN THE CREATION OF URNFIELD GRAVES

*Arjan Louwen*

### **A means to an end?**

In Bronze Age (BA) Europe, it was not just the copper ores that found themselves being submitted to the transforming qualities of fire. In this very same period, the practice of ‘*cremation*’ really started to become an important way of dealing with a dead body, both in the British Isles and on the continent (Harding 2001:318–325; Cunliffe 2008). At the dawn of the last millennium BCE, cremation had even become the dominant funerary rite in most communities inhabiting the vast area between the Atlantic coast, South Scandinavia, Sicily and the Carpathians (Harding 2000:77, Table 3.1; Cunliffe 2008:fig. 8.2). On the continent, the dominance of the cremation rite is perhaps best displayed by the often vast cemeteries that would later become known as ‘urnfields’, named after the pottery vessels used to contain the cremated remains (Probst 1996:258). The graves themselves are generally described as plain and simple, as they mostly contain no more than an urn with cremated remains. If grave goods are present in the first place, they mostly consist of pieces of accessory pottery or the occasional (few scraps of burned) metal object, mostly related to personal adornment (bracelets, pins) or appearance (razors and tweezers). Still, as urnfields can contain up to several hundred graves, they form one of the most abundant funerary legacies of later prehistory in Europe.

Excavations of urnfields are known to have been carried out by clergymen and physicians from the early 18th century onwards (Nunningh 1713), and by the time archaeology had established itself as a scientific discipline, urnfields were already accepted as a widespread funerary tradition marking the capstone of the European BA (Jockenhövel 1994:11; Cunliffe 2008:234).

As a result, urnfields seem to have gradually grown into an archaeological construct of their own (Sørensen & Rebay 2008), while the urns and objects collected from urnfield graves often still function as static representations of *time* and *culture* (e.g. Verlinde & Hulst 2010). Related to this latter critique is the general tendency to read the contents of graves as direct representations of the deceased's former social role (Sørensen 2010:56). This is basically how the seemingly plain and simple urnfield graves, which often lack grave goods, became known as representing egalitarian peasant village societies (Childe 1950:200; Kristiansen 1998:113).

There are, however, different ways of distilling meaning from tacit bones and silent grave goods, not just for urnfield graves but for grave contexts in general. *Death*, to start with, is a major social event. Like at weddings, it is one of those rare occasions where people from all chapters of a person's life are gathered in the same place. These strange reunions not only emphasise the social significance of death but also introduce the most important actors of the mortuary process to the stage: the mourning community. As the dead do not bury themselves, what we see in a grave should not just be seen as a portrait of the deceased but as a reflection of a community's ideas about social and cosmic order in the face of the loss of one of its members (see Metcalf & Huntington 1991). Altogether, the way a dead body is treated, positioned and provided with certain categories of objects provides tiny hints about the way communities try to make sense of the world around them (*idem*). Furthermore, since funerals tend to draw an audience, they even constitute a way to communicate social statements (see Oestigaard & Goldhahn 2006; Fowler 2013). In this view, the *practices* that finally result in the material manifestations archaeologists encounter in grave contexts are as important as the contents themselves, if not more important. What follows is that even the most simple graves should be regarded as *meaningful composite artefacts*.

When applying this view to urnfield graves, a few things immediately stand out. First of all, the dead not only needed to be cremated, but the cremated remains *also* needed to be buried. Why go through all the trouble of cremating someone if you are still going to bury that person anyway? This observation alone already suggests that cremation itself was seen as more than just a metaphorical transformation of the dead person. Additionally, many of the objects represented in urnfield graves either underwent the same destructive process of burning or were deliberately broken and taken apart before being (partially) added to the grave. Noting this parallel between the state of the corpse after cremation and the treatment of grave goods throughout the mortuary process, it will be argued in this chapter that the practice of cremation, next to its symbolic meaning(s), might as well have been a means to an end: *the fragmentation of a person*. Moreover, in this way, both fragmented bodies and objects could serve as vehicles in creating new entities and emphasising links between persons, objects and places.

### Setting the stage: the urnfield mortuary process as a narrative

To understand how and why the practice of fragmentation was important in the creation of urnfield graves, it is necessary to put the urnfield mortuary process in a theoretical social and archaeological context first. For this research, inspiration was drawn from the work of Chris Fowler, who recently argued that funerals in general can in fact be read as narratives in which the (social) transformation of the dead is played out (Fowler 2013). Throughout this mortuary narrative, the multiple social personae of the deceased (re) surface and are reflected upon by the mourning community, while social statements important to the said community are made (Fowler 2013:513; see Saxe 1970:235). For the urnfields, cremating corpses and breaking grave goods were in some way essential elements to this mortuary narrative. But what archaeological indicators do we have at our disposal to reconstruct such a mortuary narrative in more detail?

As we are dealing with cremation graves, at least three stages in the mortuary narrative can already quite simply be deduced: (1) someone died; (2) was cremated; and (3) eventually buried. These three points are evident from the archaeological record, and the chronology could be filled in with quite some detail (see Figure 3.1) based on either archaeological evidence (e.g. the complexity of the grave and monument) and/or ethnographic evidence (e.g. the time concerned with open-air cremations).<sup>1</sup> The intermezzos in between these three stages, however, are much more elusive, as all actions performed would have happened above ground, at locations not directly associated with funerary sites (e.g. in and around the house), or have left no clear direct archaeological evidence at all. When the practice of fragmentation is concerned, it is exactly one of these elusive intermezzos that is important: the time between cremation and interment. Since cremation turns a corpse into a

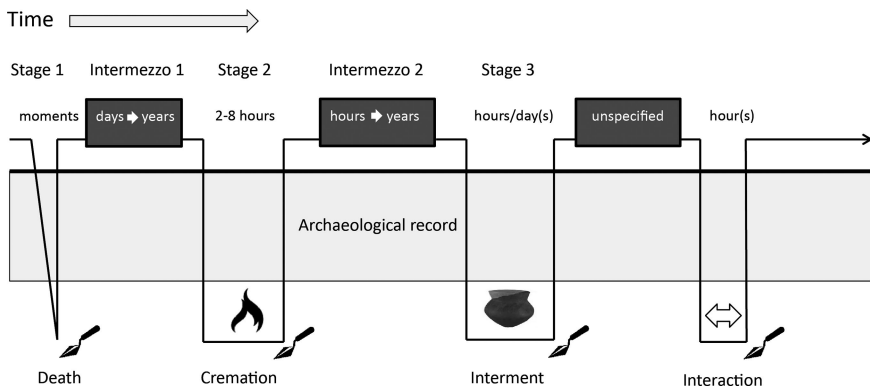

FIGURE 3.1 The urnfield mortuary process from an archaeological perspective (adapted version of Louwen 2021:fig. 3.7).

tangible heap of calcined bones, the deceased becomes both durable and storable, eliminating the need for a quick burial (e.g. Oestigaard & Goldhahn 2006; Rebay-Salisbury 2010). Therefore, the possibility must be considered that the actual burial could have taken place even years after cremation, providing the mourners with ample time to interact with and manipulate both bones and objects associated with the dead person.

A (final) stage that should be mentioned here as well concerns the unspecified time after interment when relatives return to the grave from time to time to interact with the dead, perhaps as acts of commemoration. Concrete evidence for this stage in regard to the studied urnfields consists of the placement of (broken) objects in the circular ditches surrounding the graves (Louwen 2021:178–182.)

### **Urnfields on the edge of the continent: the Lower Rhine Basin**

The basis for the present study is formed by recent research into the funerary practices associated with urnfields in the Lower Rhine Basin (Louwen 2021). The region sits on the western edge of the *Northwest European Plain* and comprises the present-day Netherlands, north Belgium and west Germany. As the name already suggests, the landscape is only slightly undulated and, at the time of the urnfields, would have consisted of a patchwork of sand plateaus, stream- and river valleys, levees and vast peat bogs. Important to mention is that in the *Lower Rhine Basin*, both the LBA (1100–800 BCE) and the EIA (800–500 BCE) are counted among what is traditionally regarded as the Urnfield period (Gerritsen 2003:15). Recent excavations, however, reveal an ever-growing number of funerary sites that start way before 1100 BCE (e.g. Dyselinck 2013) or continue to be used for burials well into the Middle Iron Age (MIA) and later (e.g. Hiddink & de Boer 2011; Blom & van der Velde 2015).

Most urnfields in the Lower Rhine Basin are characterised by large collections of small funerary monuments in the form of round mounds encircled with ditches, but other structures like long mounds and keyhole-shaped monuments also occur. The graves themselves are often small shaft-like pits containing an urn or a tight bundle of cremated remains. In the Netherlands alone, some 700 sites are known to have produced graves dating to either the LBA or EIA (Louwen 2021:23–25). Eventually, 75 well-excavated and well-published cemeteries were selected for further research. Taken together, these sites produced 3,182 graves (idem), of which 3,137 were cremation graves (Louwen 2021:85). Every single one of these graves has been studied for 45+ variables that may illuminate specific funerary practices. Among other things, these included the type of monument, the type of grave, the use of urns, the presence and treatment of grave goods and the positioning of both cremated remains and objects inside the grave. Where possible, these variables have

also been studied in relation to the age and sex of the deceased. Overall, the study provides a unique insight into how the mortuary narrative associated with the urnfields was played out in the Lower Rhine Basin and how the fragmenting of both bodies and objects was an essential element of this narrative.

### **Piece by piece**

First of all, a cremation had to be arranged for each of the 3,137 cremation graves in the dataset. Wood had to be collected, a pyre had to be assembled and the corpse had to be prepared as well. Judging from the burned state of many body ornaments in the dataset (Louwen 2021:Table 5.8), corpses were probably dressed up nicely before cremation. Unfortunately, we do not know where the actual cremation took place. In the Netherlands, only one cemetery, which was not part of the dataset for this study, yielded clear evidence for the presence of a pyre within the confines of the cemetery itself (Hissel et al. 2012:fig. 7.43). It is not unlikely that cremations would have taken place inside or close to the cemetery. However, the problem is that pyres are built on the surface, and even though high temperatures could be reached, the heat would only have marginally affected the subsoil underneath the pyre (McKinley 1997:134). It is only from the MIA onwards that we can clearly see that the location of the pyre is also used for burial with the introduction of the so-called cinerary mounds (Hessing & Kooi 2005:637).

When the cremation rite began, it is safe to assume that at least part of the mourning community was present as well since someone had to light the fire and keep the burning pyre in check while the cremation ensued for two to eight hours (McKinley 1989:67). The burned state of many grave goods retrieved from urnfield graves (Figure 3.2) suggests that the deceased could already have been provided with these at the stage of cremation. Most of the burned grave goods bear reference to the consumption of food and drink, such as small pottery cups with ears and the legbones and ribs of cattle, sheep and pigs (Louwen 2021:148–149, Table 5.9). These grave goods could either have functioned as food offerings that accompanied the corpse on the pyre or represent a reference to a funerary meal held by the mourners in honour of the deceased. Although presence at the pyre site is the most straightforward explanation for the burned state of these grave goods, it cannot entirely be excluded that their burned state was caused by other fiery occasions outside the funerary context. Burned pottery, for example, is also found in contemporary contexts around the house in the form of depositions (Gerritsen 2003:97; De Vries 2016:96). However, it remains remarkable that all categories of grave goods that show signs of burning also occur in an unscathed or (just) fragmented state. Apparently, both the stage of cremation and the stage of interment were deemed suitable occasions to provide the deceased with objects and/or food offerings. The most striking example of this is the



**FIGURE 3.2** Burned pottery cup from an Early Iron Age urn at Deventer – ‘t Bramelt (left). Amber beads from a Late Bronze Age urn at Maas-tricht – Ambyerveld (right). One of the beads has been broken into two pieces. One half was missing from the grave (Dyselinck 2013, fig. 3.22).

only two daggers that were recorded for the present dataset. These respective (*antenna*) daggers were retrieved from two contemporary EIA cemeteries in the southern Netherlands, situated some 40 kilometres apart as the crow flies. While the example from Haps was found laid out in the grave unscathed (Verwers 1972:55–58), even still sheathed, the dagger from Someren had been burned along with the corpse on the pyre (Kortlang 1999:158).

Combustion grades studied for 1,117 graves in the dataset show that cremations were carried out thoroughly; in almost 95% of these cases combustion grades of IV (550–750 °C) and V (>750 °C) have been recorded (Louwen 2021:tab. 4.2). This is an important observation, it underpins that what the mourners witnessed was a complete transformation, dissolution or destruction of the corpse rather than some sort of ritual cleansing by fire. At this stage of the cremation, the body of the deceased no longer resembles its former human shape but is in a shattered and fragmented state (see Rebay-Salisbury 2010). With the cooling down of the pyre debris (or through the active dousing of it), we now enter one of the most crucial stages of the mortuary process. At this point, an important decision needed to be made: how to deal with these fragments of a former human being?

Since urnfield graves are in fact cremation graves, the simple answer to this question would be that the cremated remains were either wrapped or contained and transported to the location of the grave to be interred. As mentioned earlier, however, this is exactly the stage in the mortuary process when the mourning community disappears from the archaeological record (Figure 3.1), only to resurface at the stage of interment. We can get a last glimpse

of them at the pyre site by deducing how cremated remains were collected from the pyre debris, assessing if they were cleaned, the degree of fragmentation, and finally, the representativeness of the cremated remains themselves.

Starting with the first, the dataset yielded examples of both ‘clean’ cremated remains (no traces of charcoal in the grave) as well as examples where fragments of the pyre debris have been detected in the grave (Louwen 2021:tab. 6.3). In these latter cases, the pyre debris itself was clearly also regarded as an important constituent of the grave, perhaps as a reference to the event of the cremation earlier in the mortuary process or based on the idea that body and pyre were now melted into the same substance. The graves that contained no charcoal particles could indicate that the cremated remains had been carefully selected or even washed before interment. Interestingly, both practices were often observed within the same cemetery and on contemporary graves (Louwen 2021:168).

Both the degree of fragmentation and the representativeness of the cremated remains prove to be problematic proxies from a taphonomical point of view. For the present dataset, no clear observations exist for deliberate pounding or grinding of cremated remains. The poor preservation of the vast majority of the graves also makes it difficult to establish whether the occasional splintering of cremated remains occurred because of intentional action or because of the simple fact that these remains have been buried in shallow graves for 2.500–3.500 years within reach of ploughs, tree roots and burrowing animals.

With regard to representativeness, the present dataset only seldom yields examples of graves where the total weight of cremated remains would fall within the expected ranges established for the cremation of adult individuals (see McKinley 1993). Taphonomical causes for the modest weight of the cremated remains apply in most cases. Nevertheless, even in a small reference group consisting of graves of adult individuals (MNI = 1), which could with a fair amount of certainty be regarded as intact graves, the total weights would fall a few hundred grams under the lower threshold for complete adult individuals (see McKinley 1993). Harvig and Lynnerup have, however, recently argued that for cremated remains from archaeological contexts, both mass and volume are not only heavily reduced by taphonomy but also by our own (post-)excavation handling (Harvig & Lynnerup 2013:2719–2720). Caution is therefore urged when using total weights for assessing the completeness of cremated remains (see Louwen 2021:92–103 for an elaborate discussion). The dataset did, however, yield a few clear examples of token deposits where less than 100 grams<sup>2</sup> of cremated remains have been collected from intact graves (Louwen 2021:tab. 4.6). For instance, at the cemetery of Nijmegen-Kops Plateau, an intact urn was unearthed that only contained a single piece of burned human bone (Fontijn & Cuijpers 1999:52). These examples show that fragmented bodies could indeed be further fragmented during the period

between cremation and interment. It is not unlikely that this also happened for a large share of the graves that show total weights above 100 grams. Conversely, the dataset also yielded at least 51 graves containing the remains of multiple individuals (Louwen 2021:tab. 4.7); in some graves, there were as many as seven individuals (Roymans & Hoogland 1999). Especially in this latter example, it seems unlikely that these seven individuals were all cremated on the same pyre or that their cremated remains were put together to save space in the cemetery. More likely, we are dealing with a scenario in which (portions of) the cremated remains had been stored after cremation and were finally buried together.

When, after an unspecified period of time (see Figure 3.1), we again meet the mourning community gathered around a fresh burial pit, we see how cremated remains, pyre debris and grave goods are forged into a new whole: the grave. Cremated remains have either been collected in an urn (43–44% of the graves) or entered the ground in a different capacity. As mentioned, some objects and food offerings had already accompanied the deceased on the pyre, and these fragmented remains needed to be buried as well. At this stage, ‘fresh’ grave goods could also be added. Eventually, some 9% of the dead were provided with either a burned or an unburned piece of accessory pottery, and 5–6% of the graves had objects (mostly metal) related to personal adornment or appearance. In addition, a remarkably high number of graves (437) contained loose pottery sherds that could not convincingly be related to either an urn or a piece of accessory pottery. In quite a few cases, this would have been the result of taphonomical processes, which have heavily damaged originally unscathed pieces of pottery, but in as many cases, it seems that pottery sherds entered the grave exactly in that capacity: as pottery sherds (e.g. Dyselinck 2013).

Both loose pottery sherds and complete pieces of accessory pottery also occur in the ditches encircling the small mounds that were erected over the graves after interment (Verwers 1975:fig. 5). As these pieces of pottery are retrieved from the fills of the ditches, it means that they must have been deposited sometime after these ditches had originally been dug, suggesting the mourning community returned to the grave from time to time. Frequently, the type of pottery (small cups and pots) collected from circular ditches does not differ from the pottery added to the graves themselves. Moreover, on rare occasions, pottery sherds from graves could even be fitted together with pottery sherds collected from ditches (Louwen 2021:171). In one example from the cemetery of Geldrop – Genoenhuis, it could even be established that the fitting sherds from the grave and circular ditch had received different treatments. Where the pottery sherd from the grave itself was ‘just’ broken, the fitting sherd retrieved from the ditch had been submerged into an undefined oleaginous substance and had also been burned (Hissel et al. 2007:184).

## The related dead

In the previous section, it was highlighted where, in the mortuary process associated with urnfield graves in the Lower Rhine Basin, we see practices of fragmentation occur. It is now time to explore the possible reasons behind these practices. Taken together, many of the practices observed seem to have been geared towards creating but also emphasising *relations*. Not just relations between people, but also between people, objects and places. Fragmenting both bodies and objects would have provided people in the LBA and EIA with the means to do so.

### *Relations between people and people*

As argued above, the practice of cremation eliminates the need for quick burial and turns a dead person into tangible, durable and storable matter (see Brück 2004, 2006; Rebay-Salisbury 2010). The examples in the dataset of token deposits and the mixing of cremated remains of multiple individuals show that the above-mentioned qualities of cremated remains were employed to divide up a person and/or to forge them together. Unfortunately, aDNA cannot be used for cremated remains to see what social ties might have existed between multiple people in one grave. However, of the 51 attested cases of mixed individuals, 41 graves (some 80%) contained combinations of adults and children (<15 years of age). Though children were clearly granted a fair share of autonomy in these cemeteries (Louwen 2021:156–161), their social role (in death) might still have been attached to, or even dependent on, adult relatives. The one grave from Beegden containing the remains of seven individuals (one adult male, three adult females and three children) might even represent an entire family or bloodline (Roymans & Hoogland 1999:77). As the urn from Beegden clearly did not contain *all* the cremated remains of these seven individuals (Idem), this example not only emphasises how the dead could be divided up and merged together, but it also shows how the cremation rite allowed people to have their dead represented at multiple locations at once.

### *Relations between people and places*

The grave from Beegden was found underneath a long mound that most probably represents the oldest monument in this small cemetery (Roymans & Hoogland 1999:82). Interestingly, this was not the only burial along the central axis of the monument, as another contemporary urn was found, containing the remains of four individuals (two adults and two children). Around the long mound, a small cemetery eventually developed that was probably only in use for a short period of time during the EIA (Roymans & Hoogland

1999:81). In these surrounding monuments, several so-called *Schräghalsurns* were found; these had such distinctive decoration that one could not have been moulded without the potter at least having seen the others (Roymans & Hoogland 1999:fig. 5). All these observations amount to the hypothesis that the people buried in this cemetery were all members of the same (tight) community and that both the mixing of cremated remains and the resemblance of urns might even indicate family ties. The fact that the oldest monument in the cemetery also contained two urns with the (partial) remains of multiple individuals, which composition-wise might represent families, could mean that a group of people founded this cemetery by bringing the cremated remains of these (two?) bloodlines to the new burial ground at Beegden, while parts of these persons remained buried at the place these people once came from.

With the act of burying someone, a physical connection between a person and a place is automatically generated as the two come together at the location of the grave. Although cremation is not necessary for creating such a connection, the burial of cremated remains at least emphasises that this link is still deemed important. Additionally, the practice of cremation would have most definitely facilitated the possibility of having (future) ancestors represented at multiple locations at once. The question that remains is why this link between people and places was deemed important. The answer most probably lies in the connection people would have experienced with the land they lived on (see de Coppet 1985). As these were fully agrarian communities, they had to invest intensively in the land, and with every generation, this link must have grown tighter and more evident by the traces left in the landscape by preceding generations (see Fontijn 1996). Interestingly, cremated remains were not the only substance that entered the ground in vast numbers in this period, since various arrangements of objects occurred in relation to the land in the form of depositions (Fontijn 2019). Not only did this result in specific metal objects like swords ending up in rivers (Fontijn 2002), but also in the deposition of more mundane kinds of objects such as pottery (sherds) (Gerritsen 2003:97; de Vries 2016, 2021). This brings us to the final relationship to be emphasised by the (funerary) practice of fragmentation: between people and objects.

### *Relations between people and objects*

One of the most remarkable observations with regard to the objects in urn-field graves is that cremated remains, clearly no longer resembling human shape, were still provided with dress items such as bracelets and pins. These personal dress items have predominantly been found in the graves of adult individuals.<sup>3</sup> This could mean that these types of objects were earned at a certain age, were deemed inalienable from the people wearing them (Brück

2004, 2006) and could not be separated from their owners even at death. This inalienability might also have been the reason for these objects to have sometimes been deliberately fragmented so that they could serve as references to (dead) persons beyond the context of the grave. For example, at the cemetery of Maastricht – Ambyerveld, three amber beads had been placed on the bottom of an urn (see Fig. 3.2). One of these beads had been deliberately cut in half. While one half was placed in the urn, the other half was clearly missing from the grave (Dyselinck 2013:86–88). The same observation was made in the case of a bronze bracelet from another grave in the same urnfield (*idem*). By acting in this way, links with contexts outside the grave were automatically generated; these same personal items were now spread out over different locations, perhaps still bearing a connection to their previous owners. The same probably also applied to the above-mentioned examples of pottery sherds that were added to the grave. Breaking a pot might have been deemed metaphorical for the state of the dead person, and like the cremated remains themselves, it could be used to negotiate the presence of, or reference to, the same person in different locations.

### **A socialised landscape: people, places and objects**

This chapter sets out to explore the practice of fragmentation in relation to urnfield graves in the *Lower Rhine Basin*. It was argued that many of the observed practices seem to have been geared towards creating and emphasising relations between *people*, *places* and *objects*. The practice of cremation itself, as well as the practice of dividing up and merging fragments of both persons and objects, was clearly an important way of negotiating these relations. Overall, the observations are very much in line with the ideas put forward by Brück and Fontijn, who argue that in the course of the BA people, objects and places grow ever more inextricably linked in the creation of social identities (Brück & Fontijn 2013:213). By distributing fragments of persons and objects (that bear references to persons) over the land(scape), it is as if these social identities are written down in the land(scape) itself in the form of burial mounds, selective depositions (Fontijn 2002, 2019), as well as fragments kept in the domestic spheres (Brück 2004, 2006). In this way, the land(scape) grew ever more socialised throughout the BA, imposing a certain way of *acting* on the generations that came after (see Fontijn 1996). In a sense, the emergence of urnfields can be seen as an almost inevitable result of this intricate interplay between people (ancestors?), places (land) and objects (as extensions or counterparts of persons) that started way earlier in the BA. If we want to gain a better understanding of why the urnfield mortuary narrative was played out the way it was, it is in this direction that we must search.

## Notes

- 1 For a detailed discussion of the timeframes involved in this ‘mortuary flow-chart’ see Louwen 2021:41–52.
- 2 Joachim Wahl (1982) specifically mentions intact graves containing only between 0.1 and 100 grams as representing intentionally incomplete or symbolic interments (Wahl 1982:24).
- 3 14 adults vs 1 child.

## References

- Blom, E. & H.M. van der Velde. 2015. De archeologie van Boxmeer-Sterckwijk: 4500 jaar wonen, werken en begraven langs de Maas. *ADC-monografie* 18. Amersfoort.
- Brück, J. 2004. Material metaphors: the relational construction of identity in Early Bronze Age burials in Ireland and Britain. *Journal of Social Archaeology* 4(3): 7–33. <https://doi.org/10.1177/1469605304046417>.
- . 2006. Fragmentation, personhood and the social construction of technology in Middle and Late Bronze Age Britain. *Cambridge Archaeological Journal* 16(2): 297–315. <https://doi.org/10.1017/S0959774306000187>.
- Brück, J. & Fontijn, D.R. 2013. The myth of the chief: prestige goods, power and personhood in the European Bronze age. In: H. Fokkens & A. Harding (eds) *The Oxford handbook of the European Bronze Age*. Oxford: Oxford University Press, 197–215. <https://doi.org/10.1093/oxfordhb/9780199572861.013.0011>.
- Childe, V.G. 1950. *Prehistoric migrations in Europe*. Oslo: Aschehaug.
- De Coppet, D. 1985. Land owns people. In: R.H. Barnes, D. de Coppet & R.J. Parkin (eds) *Contexts and levels: anthropological essays on hierarchy*. Oxford: JASO, 78–90.
- Cunliffe, B. 2008. *Europe between the oceans: 9000 BC–AD 1000*. New Haven, CT: Yale University Press.
- Dyselink, T. 2013. *Maastricht Ambyerveld-Hagerhof. Een laat bronstijd urnenveld*. BAAC-rapport A-08.0487. 's Hertogenbosch.
- Fontijn, D.R. 1996. Socializing landscape. Second thoughts about the cultural biography of urnfields. *Archaeological Dialogues* 3(1): 77–87. <https://doi.org/10.1017/S1380203800000611>.
- . 2002. *Sacrificial Landscapes. Cultural biographies of persons, objects and ‘natural’ places in the Bronze age of the Southern Netherlands, 2300–600 BC*. Leiden: Sidestone Press.
- . 2019. *Economies of destruction: how the systematic destruction of valuables created value in Bronze Age Europe, c. 2300–500 BC*. London: Routledge. <https://doi.org/10.4324/9781315109879>
- Fontijn, D.R. & Cuijpers, A.G.F.M. 1999. Prehistoric stone circles, stone platforms and a ritual enclosure from Nijmegen. *Berichten van de Rijksdienst voor het Oudheidkundig Bodemonderzoek* 43: 33–67.
- Fowler, C. 2013. Identities in transformation. Identities, funerary rites, and the mortuary process. In: S. Tarlow & N. Stutz (eds) *The Oxford handbook of the archaeology of death and burial*. Oxford: Oxford University Press, 511–526. <https://doi.org/10.1093/oxfordhb/9780199569069.013.0028>.
- Gerritsen, F. 2003. *Local identities. Landscape and community in the late prehistoric Meuse-Demer-Scheldt region*. Amsterdam Archaeological Studies 9. Amsterdam: Amsterdam University Press.

- Harding, A. 2000. *European societies in the Bronze Age*. Cambridge: Cambridge University Press. <https://doi.org/10.1017/CBO9780511605901>.
- . 2001. Reformation in Barbarian Europe, 1300 – 600 BC. In: Cunliffe, B. (ed.) *The Oxford illustrated history of prehistoric Europe*. Oxford: Oxford University Press, 304–335.
- Harvig, L. & Lynnerup, N. 2013. On the volume of cremated remains – a comparative study of archaeologically recovered cremated bone volume as measured manually and assessed by Computed Tomography and by Stereology. *Journal of Archaeological Science* 40(6): 2713–2722. <https://doi.org/10.1016/j.jas.2013.01.024>.
- Hessing, W. & Kooi, P.B. 2005. Urnfields and cinerary barrows. Funerary and burial ritual in the Late Bronze and Iron ages. In: L.P. Louwe Kooijmans et al. (eds) *The prehistory of the Netherlands*. Amsterdam: Amsterdam University Press, 631–654.
- Hiddink, H.A. & de Boer, E. 2011. *Opgravingen in Waterdael III te Someren 1. Grafvelden en begravingen uit de IJzertijd en Romeinse tijd*. Zuidnederlandse Archeologische Rapporten 42. Amsterdam.
- Hissel, M.E. et al. 2007. *Begraven, bewonen, beakkeren: Archeologisch onderzoek bij de uitbreiding van de woonwijk Genoehuis, gemeente Geldrop-Mierlo (Noord-Brabant)*. Amsterdam Archeologisch Centrum Publicaties 29. Amsterdam: AAC.
- Hissel, M.E. et al. 2012. *Cold case in het stuifzand. Het urnenveld van de Boshoverheide bij Weert ontsloten*. Rapportages Archeologische Monumentenzorg 209. Amersfoort: Rijksdienst voor het Cultureel Erfgoed.
- Jockenhövel, A. 1994. Raum und Zeit. Gliederung der Bronzezeit. In: A. Jockenhövel & W. Kubach (eds) *Bronzezeit in Deutschland*. Stuttgart: Verlag, 11–14.
- Kortlang, F. 1999. The Iron Age urnfield and settlement from Someren – ‘Waterdael’. In: N. Roymans & F. Theuws (eds) *Land and ancestors. Cultural dynamics in the Urnfield period and the Middle Ages in the southern Netherlands*. Amsterdam Archaeological Studies 4. Amsterdam: Amsterdam University Press, 133–198.
- Kristiansen, K. 1998. *Europe before history*. Cambridge: Cambridge University Press.
- Louwen, A.J. 2021. *Breaking and making the ancestors. Piecing together the urnfield mortuary process in the Lower-Rhine-Basin, ca. 1300–400 BC*. Leiden: Sidestone Press.
- McKinley, J.I. 1989. Cremations: expectations, methodologies and realities. In: C.A. Roberts et al. (eds) *Burial archaeology; Current research, methods and developments*. British Series 211. Oxford: BAR, 65–76. <https://doi.org/10.1002/ajpa.1330870116>.
- . 1993. Bone fragment size and weights of bone from modern British cremations and the implications for the interpretation of archaeological cremations. *International Journal of Osteoarchaeology* 3: 283–287. <https://doi.org/10.1002/oa.1390030406>.
- . 1997. Bronze Age ‘Barrows’ and Funerary Rites and Rituals of Cremation. *Proceedings of the Prehistoric Society* 63: 129–145. <https://doi.org/10.1017/S0079497X00002401>.
- Metcalfe, P. & Huntington, R. 1991. *Celebrations of death. The anthropology of mortuary ritual* [Second edition]. Cambridge: Cambridge University Press. <https://doi.org/10.1017/CBO9780511803178>.
- Nunningh, J.H. 1713. *Sepulcretum Westphalico-Mimigardico-Gentile*. Coesfeldt.
- Oestigaard, T. & Goldhahn, J. 2006. From the dead to the living: death as transactions and re-negotiations. *Norwegian Archaeological Review* 39(1): 27–48. <https://doi.org/10.1080/00293650600703928>.

- Probst, E. 1996. *Deutschland in der Bronzezeit. Bauern, Bronzegiesser und Burgherren zwischen Nordsee und Alpen*. München: Bertelsmann.
- Rebay-Salisbury, K. 2010. Fragmented bodies: cremations in the Bronze and Iron Age. In: K. Rebay-Salisbury et al. (eds) *Body parts and bodies whole: Changing relations and meanings*. Oxford: Oxford Books, 64–71.
- Roymans, N. & Hoogland, M. 1999. The Early Iron Age urnfield of Beegden. In: N. Roymans & F. Theuvs (eds.) *Land and ancestors. Cultural dynamics in the Urnfield period and the Middle Ages in the Southern Netherlands. Amsterdam Archaeological Studies 4*. Amsterdam: Amsterdam University Press, 63–86.
- Saxe, A.A. 1970. *Social dimensions of mortuary practices*. Unpublished Ph.D. thesis. University of Michigan.
- Sørensen, M.L.S. 2010. Bronze Age bodiness – maps and coordinates. In: K. Rebay-Salisbury et al. (eds) *Body parts and bodies whole: Changing relations and meanings*. Oxford: Oxford Books, 54–63.
- Sørensen, M.L.S. & Rebay, K.C. 2008. The impact of 19th century ideas on the construction of ‘urnfield’ as a chronological and cultural concept. In: A. Lehoerff (ed.) *Construire le temps. Histoire et méthodes des chronologies et calendriers des derniers millénaires avant notre ère en Europe occidentale*. Glux-en-Glenne: Centre archéologique européen, 57–67.
- Verlinde, A.D. & Hulst, R.S. 2010. *De grafvelden en grafvondsten op en rond de Veluwe van de Late Bronstijd tot in de Midden IJzertijd*. Nederlandse Archeologische Rapporten 39. Amersfoort: Rijksdienst voor het Cultureel Erfgoed.
- Verwers, G.J. 1972. *Das Kamps Veld in Haps in Neolithikum, Bronzezeit und Eisenzeit*. *Analecta Praehistoria Leidensia* 5. Leiden: Leiden University Press.
- . 1975. Urnenveld en nederzetting te Laag Spul, gem. Hilvarenbeek. *Analecta Praehistoria Leidensia* 8: 23–43.
- De Vries, K.M. 2016. Together apart. Iron Age deposition practices on the Fries-Drents plateau. In: A. Müller & R. Jansen (eds) *Metaaltijden 3. Bijdragen in de studie van de metaaltijden*. Leiden: Sidestone Press, 93–104.
- . 2021. *Settling with the norm. Norm and variation in social groups and their material manifestations in (Roman) Iron Age (800 BC–AD 300) settlement sites of the northern Netherlands*. Leiden: Sidestone Press.
- Wahl, J. 1982. Leichenbranduntersuchungen. Ein Überblick über die Bearbeitungs- und Aussagemöglichkeiten von Brandgräbern. *Prähistorische Zeitschrift* 57(1): 1–125.

# 4

## BONDED BY PIECES

### Fragments as means of affirming kinship in Iron Age Finland

*Ulla Moilanen*

#### **Introduction: a brief background on kinship and archaeology**

Kinship refers to the relationships and connections between individuals based on shared bloodlines, marriage, adoption, and social ties. It encompasses the relationships and networks between members considered 'kin' and the cultural and social customs and behaviours associated with these relationships. Usually, three types of kinship are distinguished: consanguineal, affinal, and social. Consanguineal kinship refers to biological (blood) relations, and affinal kinship refers to relationships created through marriage (e.g. Sahlins 2013; Read 2015:61). Although friendships and casual acquaintances are not considered kinship relationships, kinship does not require blood ties to exist. Social kinship can be formed between individuals through strong social bonds, shared experiences, or cultural practices. This category includes, for example, adoption and co-residence (Read 2015:61).

The theoretical background to kinship in archaeology is rooted in anthropology, specifically the study of social organisation and relationships. In the 19th century, Lewis Henry Morgan (1871) argued that as human societies evolved, they developed increasingly complex systems for classifying and regulating relationships between individuals. According to him, kinship systems became more complex over time, but his focus remained on blood relationships. In the mid-20th century, Claude Lévi-Strauss (1949) expanded the concept of kinship and emphasised the importance of affinal relationships and their symbolic and cultural aspects. He proposed that kinship systems are based on the exchange of women. These 'marriage alliances' create bonds and alliances between groups and serve to regulate social relations and maintain social order. Lévi-Strauss (1982) also argued that domestic units are a

microcosm of the larger social and political order. In this view, households represent a symbolic association between the house and the occupants, and the head of the household holds both domestic and political power.

In the past decades, the notion of kinship has been re-evaluated and broadened with the incorporation of post-structural and feminist perspectives on gender, power, and social identity, as well as the recognition of the importance of agency and practice. Kinship systems are not simply biological relationships but are also shaped by cultural beliefs and values (Sahlins 2013). The systems and categories are varied can change and reform, and kin can also include inanimate objects or fictitious and nonhuman beings (Haraway 2016; Johnston 2020; Eriksen & Kay 2022). In archaeology, kinship has been approached in various ways, such as through studying settlement patterns, mortuary practices, and objects. Although kinship has been considered somewhat irrelevant in archaeology, ancient DNA analyses have brought the concept to the spotlight (e.g. Monroy Kuhn et al. 2018; Vai et al. 2020). However, the emphasis on biological relatedness can distort the idea of how kinship was understood and enacted in the past (Brück & Frieman 2021), making it worthwhile to bring the concept back into the archaeological debate. (For various anthropological, historical, and archaeological perspectives on kinship, see, e.g. Lawrence 1999; Gillespie 2000; Jussen 2000; González-Ruibal 2006; Ensor 2011; Johnson & Paul 2016; Souvatzi 2017; Johnston 2020; Brück 2021; Eriksen & Kay 2022; Fowler 2022).

In a few Finnish publications, crushed bones and broken objects, which are often encountered in Iron Age (IA) cemeteries, have been associated with ancestors and the creation of bonds with the past (Wessman 2010:87–108; Puolakka 2020:30; Moilanen 2021:81, 88), although these publications do not explicitly discuss the concept of kinship in IA societies in Finland. Kinship has been referred to mostly implicitly, as it has been suggested that households were inhabited by *families* (e.g. Asplund 2008:355). Similarly, ceramic and dress traditions have been associated with *families* (e.g. Vuorinen 2009:194), and it has been suggested that the political power and economy in the IA were controlled by chiefly *families* and their networks (e.g. Raninen & Wessman 2015:275). However, the concept of family is seldom defined, and it has only been discussed in detail in a few Finnish publications. Drawing on Scandinavian research, Sirkku Pihlman (2004:53) has suggested that Finnish communities formed kinship-like social bonds through concubinage and a foster system during the Viking Age (c. 800–1025 CE). In the latter, a child could be raised in another household as a sign of mutual favour and as a creator of family ties. According to Pihlman, slaves were excluded from these social systems; therefore, their burial practices differed from the others – perhaps they were not even buried in a visible way.

Family and kinship systems are known to change and vary over time (e.g. Parkin 2021), and it is difficult to say how many changes occurred during the

IA. It is usually assumed that the concept of the nuclear family (a pair and their children) is a recent concept (Kertzer 1991), which immediately complicates references to families in the past. For example, in the classical world, the family also included extended family members and even slaves (Rawson 1986). A complete understanding of the concept of ‘family’ in IA Finland would require a detailed discussion of not only who was included or excluded in kinship networks but also how kinship was formed and negotiated. This discussion is essential, as kinship is directly connected to local power structures, social norms, and values reflected in archaeological material. Describing how kinship was understood, formed, and maintained may help to understand inheritance and property rights and provide insights into how social structures and power relations vary and change over time. Although critical issues exist, this is beyond the purview of this article. Instead, this chapter will outline how kinship may have been presented in funerary rituals, especially in connection to fragmentation, and what the ritual act of breaking bones and bodies and handling fragmented material may have aimed to achieve.

### **Fragmentation and Iron Age burials in Finland**

Fragmentation characterises the burial practices of the IA in Finland. The so-called ‘cremation cemeteries’ under flat ground were used for hundreds of years (c. 500–1100 CE), and they commonly contain chopped and bent objects (Figures 4.1 and 4.2) as well as crushed cremated bones. The crushed bones and broken objects were usually scattered around the cemetery in a seemingly chaotic manner, and individual burials are rarely discernible (e.g. Wessman 2010).

Alongside the collective cremation cemeteries, burials were also made in cairns (Figure 4.3). The cairns may contain only a small amount of human bones, sometimes only a few pieces, as well as fragmented objects and potsherds that do not comprise entire vessels. The deposits in cairns are not always clearly identifiable as burials, and a question often arises as to whether cairns were built for burials or whether they could have been ritual structures built especially for ancestor worship (e.g. Raike & Seppälä 2005:73; Muhonen 2008). While cairns and cremation cemeteries dominate the IA landscape in southern Finland, individual cremations on flat ground or in natural rock formations are known in northern and inland Finland. It is also common for these burials to contain only a few bone fragments, never the full cremation material from a complete body (e.g. Hakamäki 2018:94).

At the beginning of the second millennium, inhumation burials began to appear in Finnish cremation cemeteries. These graves may have been dug through the cremation layers, and broken artefacts from the cremation cemetery may have been deliberately placed in the inhumation graves. On the other hand, early medieval cemeteries may include a mixture of cremation



FIGURE 4.1 A twisted penannular brooch with rolled terminals. The pin has been removed. A find from a cremation cemetery at Toijala, Kirkkomäki, Southern Finland (photo: Ulla Moilanen).



FIGURE 4.2 A tightly bent scramasax found from a cairn at Ylistaro Leikkimäki in Kokemäki, Western Finland. The handle parts have been removed (photo: Ulla Moilanen).

and inhumation burials. In these cases, cremated bone fragments may have been placed in a container or bag before being placed either in a separate pit or in an inhumation grave, where both cremated and uncremated remains share the space (e.g. Moilanen 2021:69–71).



**FIGURE 4.3** Cairns at the archaeological site of Harola, Eura, Western Finland. The IA site consists of over 700 stone cairns, of which only a few have been excavated. The structures contained ceramic shards, iron slag, unburnt animal bones, and a few fragments of cremated human bones (photo: Ulla Moilanen).

In summary, all Late Iron Age (LIA) burial types may contain broken and burned objects and crushed cremated bones. While cremated bones were handled after the cremation, the breaking of objects could have been done at different times, before or after cremation (Karvonen 1998:9; Moilanen 2008:29, 30), and differences in ways of breaking artefacts can be observed between cemeteries. The crushing and breaking of bones and objects was clearly a part of the mortuary ritual, and various motives for it have been proposed. The usual suggestions in Finnish contexts have been summarised by Johannes Karvonen (1998). His summary derives from various international sources, and they include, for example, a practical explanation in which long objects, such as swords and spearheads, could have been bent to fit better into the burial pit or between the stones of the cairn. However, this does not explain why small objects have also been broken. The act of breaking has also been seen as a way of transferring the souls of the objects to the afterlife with the deceased. A third explanation is that chopping or twisting marked the objects as the property of the deceased and thus prevented the dead from returning and harming the living. A fourth explanation is that the breaking of objects renders them unusable, and the act would have prevented grave robbing. It has also been suggested that broken objects could reflect cosmology

and the belief about the nature of the afterlife: it was a mirror image of the world of the living, and in there, objects were broken and incomplete as opposed to the world of the living, where they were intact. The breaking of objects and the fragmentation of human remains may have included similar beliefs (Hymylä 2004:42), and the fragments of bodies and objects may have been seen as interlinked, without differences between them (Brück 2006). In this perspective, both cremated objects and bones can be considered to be in a liminal space between life and death, and the act of breaking is associated with a transition between the worlds (c.f. Rebay-Salisbury 2010).

The most often applied theories involve ancestors, as ancestors are considered a defining element in IA beliefs and so important that the belief shaped all rituals and played a significant societal role in the period (e.g. Baudou 1989; Shepherd 1997:20; Muhonen 2008:295; Lang 2011:111; Laidoner 2020). In the case of Finnish cremation cemeteries, it has been suggested that the purpose of the burial ritual and the breaking of objects was to transfer the deceased individual to the collective world of the ancestors (Wessman 2010:60). However, there have been no actual definitions of what ‘ancestors’ actually mean, other than a vague set of previous generations (Wessman 2010:87–108; Puolakka 2020:30; Moilanen 2021:81, 88). This chapter takes the approach that both ancestors and the ritual practitioners (the users of cemeteries) represent kin – not necessarily biological relatives, but a group of individuals with whom the people felt a sense of connection. It is not certain to what extent cemeteries were understood as burial places for individuals, especially when the sites may have been used for centuries. Therefore, the notion of kinship becomes entwined not only with past individuals or ancestors but also with *place*. According to Hamish Forbes (2007), “the idea of a landscape representing a kinship system is ancient”, and as James Leach (2019) has written, “places are not only where things happen; they are part of what happens”. The location of the cemetery as the place of performing rituals would therefore have been a relevant factor, and the notion of kinship could have been extended from relationships between people to entanglement between people, landscape, and place (see Chapman 2000; Chapman & Gaydarska 2007; Johnston 2020), in this case, through the ritual of breaking and handling the fragmented remains (see also Jones this volume; Chapman this volume).

The IA cemeteries in Finland are generally considered household cemeteries used by a single farm or several cooperating farms until larger village cemeteries were established in the LIA and at the turn of the Medieval Period (Asplund 2008:34; Haggrén 2015:393; Raninen & Wessman 2015:310). A household is the basic unit of domestic life, usually consisting of a group of people living together and characterised by shared tasks, economic dependency, and emotional ties. Household formation, on the other hand, is a complex process that is influenced by social, cultural, and economic factors.

We currently do not know whether all the IA household members were related by blood or to what extent the household was formed through cohabitation arrangements (c.f. Vuorinen 2009:193 and the reference list). However, assuming that the persons with the highest hierarchical position in the household (a farm) were responsible for burial in their own cemetery and they were also the ones entitled to a burial in the same place (e.g. Pihlman 2004; Kuusela 2012), the burials in a certain cemetery would thus represent the dynamics between the people bound to a particular place. It has been suggested that the farms using certain cemeteries practised economic cooperation and possibly shared family ties (Asplund 2008:34). This means that we can assume that these groups had strong social and/or biological ties with each other and were bound to the economic and social spheres of the farm and the cemetery. These groups can be referred to as kin groups, and taking the idea slightly further, it can be stated that the rituals performed at the cemeteries can be approached from the perspective of maintaining or breaking these kinship ties.

### **Various ways of connecting with kin through fragments**

As described, IA burial customs involved destroying and breaking objects and human bodies. Objects were broken in various ways, for example, by twisting, bending, chopping, and cutting, while bones could be crushed. A selection of these fragments were scattered around burial sites, and it has often been wondered why cremation cemeteries and cairns do not contain the bones of entire individuals or complete objects. The modern Western perception of burial is easily influenced by the idea that a burial involves placing a complete body in one particular place. However, dividing the fragmented human remains and pieces of objects and dispersing them in different locations has occurred in different parts of the world at different times, and the motives behind the practice could have varied. For example, according to Old Norse sagas, king Hálfdan's remains were buried in several burial mounds to mark his political territory (Steinsland 2011:41), and pottery pieces from the same vessel have been deliberately placed in different, not adjacent, graves in early Medieval England (King 2004:227–228). As an explanation for partial bodies in IA cemeteries in Finland, it has been suggested that the bones and objects of the individual could have been divided between places (Söyrinki-Harmo 1984:118) or that the cremated material could have been distributed among relatives (Hakamäki 2018:92). This kind of sharing of objects, even human remains, between kin can strengthen kinship ties and reinforce the sense of belonging to a shared group (e.g. Sahlins 2013; Morton et al. 2019). The practice can also take other forms, such as the use of commemorative objects and heirlooms, which could have passed within kinship groups as symbols of shared bonds (Joyce 2000).

The phenomenon of passing keepsakes or heirlooms can be seen in Finnish IA and early medieval inhumation graves, which sometimes contain objects that are too old in relation to the age of the burial (Riikonen 2005; Wessman 2010:114–115). It is difficult to see a similar practice in the Merovingian period and Viking Age (c. 550–1050 CE) cremation cemeteries due to their dispersed nature, but occasionally the cremation cemetery finds include artefacts dating to the Early Roman or Migration Period (c. 200–500 CE). Usually, these artefacts are taken as evidence of the cemetery's earliest period of use. However, it is equally possible that the artefacts were, in fact, heirlooms and were deposited in the cemetery later (Wessman 2009). Even the distribution of fragmented objects could help identify possible kinship connections. For example, suppose fragments of objects found in multiple locations could be identified as belonging together (see Noterman this volume). Provided that chronological relationships could be established, the fragments could also be interpreted as an indication of their being passed among kin members, who used them at different times in different places for different purposes.

According to Lund and Arwill-Nordbladh (2016:431), the LIA Scandinavians used their understanding of the past to establish identities and demonstrate power. Although this emphasises the meaning of ancestors, *kinship* often plays a significant role in negotiating politics in many societies. This is manifested, for example, in kinship-based alliances or social organisations, which in turn shape and influence decision-making in communities (e.g. Arnold 2000; Sahlins 2013). Kinship is often seen as a fundamental element of social organisation (Ensor 2011), and kinship relationships often involve cultural, social, and economic obligations and responsibilities (Finch & Mason 1991). Members of the same kin group can be expected to provide care and emotional and economic support and sometimes make sacrifices for each other. These obligations create a sense of belonging. Therefore, kinship can be understood as a fundamental feature of human experience that shapes how individuals relate to each other and understand their communities and the world around them (e.g. Sahlins 2013; Johnson & Paul 2016:80). However, kinship is not always automatic; it can be built through various rituals and social actions at different times (e.g. Brück 2021:230). Because burial is, in many ways, social dialogue, kinship can also be seen as an essential element behind mortuary rituals. Burial rituals and cemeteries enable the maintenance and creation of kinship ties. The main element here is a sense of connection with a place and the people the burial site represents, not a biological link to previously buried individuals or ancestors *per se*.

Various rituals could have aimed to emphasise the complex ideas of connectedness and make kinship ties visible. An exciting example of this is the inhumation grave 2/1913 at Pahnainmäki, Hämeenlinna, southern Finland (see Moilanen 2021:73). The grave was located in a cremation cemetery, and

it contained cremated bones and broken artefacts that were several hundred years older and clearly used as part of the burial ritual. The cremated bones were found in a circular area on the stomach of the corpse, which could indicate that they were originally collected in a bag or a container. The cremated and broken objects included brooches, glass beads, bronze chain fragments, a chain distributor, and a neck ring. Many of the objects had been balanced on the body as if they had been actual dress accessories: the brooch had been placed at the chest and the chain distributor on the right side of the chest. The three fragments of a broken neck ring had been placed around the individual's neck. This means that the placement of the fragments must have happened after the corpse had been lowered into the ground.

The Pahnainmäki grave is an excellent example of how the fragmented objects were integrated into the inhumation burial ritual and how they were possibly associated with making connections with the past, perhaps as a symbol of the continuation of kinship connections between the previous users of the cemetery but also with the living individuals who took part in the mortuary ritual. This need for interaction could have emerged from a sense of belonging (see Day 2012), for example, to a certain social group, network, or place. Since cemeteries were closely connected to farms, the concept can be extended to notions of ownership. Ownership, or a sense of ownership, can connect a person to important places. In this case, cemeteries were connected to homes and livelihoods, of which the farm and house could be seen as the centres (see Seiser 2000:93). Therefore, the ritual of establishing or reinforcing kinship ties with past generations could also express the appropriation of a particular place, specifically farms and household cemeteries that were connected to each other. The ritual importance of certain places, such as territorial boundaries, sacred places, cemeteries, and sometimes also domestic spaces, is well known (Bradley 2005). Ritual performances at these locations may have included different acts, for example, eating or drinking (c.f. Kuusela 2018), or in the case of IA funerary rituals, the breaking of objects and the distribution of fragments to different locations or persons.

The acts of breaking objects and crushing bones can also reflect connections and bonds in other ways. Breaking can be a symbolic act to denote dividing, such as the Greek custom of breaking a coin between two people when parting (Rowlinson 2010:1). However, it can also serve as a uniting act, especially when connected to a rite of passage. An example of this can be seen in the breaking of a glass to end the Jewish wedding ceremony, which serves as a reminder of the fragility of life but also as a symbol of the couple's commitment to each other and the joining of two families (Goldberg 2003:131). Also, the act of breaking, in funerary contexts, may serve as a shared experience that reinforces the bonds between ritual participants (c.f. Lewis 1994:585), and through the act, kinship relationships could have been created, recreated, and maintained (c.f. Brück 2021:230). This may also

explain why there are noticeable differences in burial rituals between cemeteries: chopped objects in some and bent objects in others (Karvonen 1998). Rituals were modified by different kin groups and adapted for purposes that served individuals best at different times. Since all the fragments did not end up in cemeteries, they could have been used by the kin group members in different places they considered important and relevant. It has also been suggested that a sense of communal connection could have been achieved through physical proximity and touching objects and their fragments that had been in contact with a specific item, person, or place (c.f. Fiske 2020). If this connectedness between people, objects, and places was considered relevant in IA northern Europe, it would give a reason for keeping and storing the finds instead of discarding them.

In summary, the ritual breaking of bones and objects in IA funerary rituals may have strengthened the sense of belonging and bound the individuals into the broader family and community networks. The act of breaking and distributing objects would have been specifically related to places that included the farm and the cemetery, although not exclusively, as fragments also seem to have been taken to other places. In general, the fragments and their handling at a particular site can be linked to a kin group that is represented by the specific household(s) associated with a specific farm and cemetery. This relationship likely changed when Christianity was officially adopted in c. 13th century CE and the church began to define the framework of political power in communities. This also marked changes in the use of cemeteries. They became communal in a different way and no longer represented the burial place of one kinship group but the whole parish, which included several households. On the other hand, the placing of burnt bones in inhumation graves continued at some sites, possibly as a way of maintaining ties to the social network of specific individuals (for previous interpretations of the practice, see Moilanen 2021:69–70). It is noteworthy that this practice involved only the handling of fragmented human remains, not objects, which indicates changes from previous practices and motives.

## Conclusions

Kinship relationships may be expressed and reinforced in various ways through symbols and practices. This article suggests that LIA Finnish cemeteries were used by specific kin groups that shared biological, social, and emotional ties with each other. These ties were established within households, cemeteries, landscapes, and economic areas used by certain kin groups. As IA cemeteries and graves often contain fragmented material, the acts of breaking artefacts, crushing bones, and sharing and distributing the fragments may have been a shared experience that created, maintained, and strengthened the connections between the ritual performers, previous generations, and places. The observable differences in rituals can be explained by different kin groups

and individuals modifying and adapting the actions for different purposes. Generally, the production and handling of fragmented material reflect the continuing presence and influence of kin and kinship in people's lives.

## References

- Arnold, J.E. 2000. Revisiting power, labor rights, and kinship: archaeology and social theory. In: M.B. Shiffer (ed.) *Social theory in archaeology*. Salt Lake City: University Of Utah Press, 14–30.
- Asplund, H. 2008. *Kymittä. Sites, centrality and long-term settlement change in the Kemiönsaari Region in SW Finland*. Turku: University of Turku.
- Baudou, E. 1989. Hög - gård - helgedom i Mellannorrland under den äldre järnåldern. *Arkeologi i norr* 2: 9–44.
- Bradley, R. 2005. *Ritual and domestic life in prehistoric Europe*. New York: Routledge.
- Brück, J. 2006. Fragmentation, personhood and the social construction of technology in Middle and Late Bronze Age Britain. *Cambridge Archaeological Journal*, 16(3): 297–315. <https://doi.org/10.1017/S0959774306000187>
- . Ancient DNA, kinship and relational identities in Bronze Age Britain. *Antiquity* 95(379): 228–237. <https://doi.org/10.15184/aqy.2020.216>
- Brück, J. & Frieman, C.J. 2021. Making kin. The archaeology and genetics of human relationships. *TATuP - Zeitschrift für Technikfolgenabschätzung in Theorie und Praxis / Journal for Technology Assessment in Theory and Practice* 30(2): 47–52. <https://doi.org/10.14512/tatup.30.2.47>
- Chapman, J. 2000. *Fragmentation in archaeology: people, places and broken objects in the prehistory of South Eastern Europe*. London: Routledge. <https://doi.org/10.4324/9780203759431>
- Chapman, J. & Gaydarska, B. 2007. *Parts and wholes: fragmentation in prehistoric context*. Oxford: Oxbow.
- Day, A. 2012. Extraordinary relationality: ancestor veneration in Late Euro-American Society. *Nordic Journal of Religion and Society* 25(2): 169–181.
- Ensor, B.E. 2011. Kinship theory in archaeology: from critiques to the study of social transformations. *American Antiquity* 76: 203–227.
- Eriksen, M.H. 2022. Body-worldings of later Scandinavian prehistory: making odd-kin with two body-objects. *Current Swedish Archaeology* 30: 65–94. <https://doi.org/10.37718/CSA.2022.09>
- Eriksen, M.H. & Kay, K. 2022. Reflections on posthuman ethics. Grievability and the more-than-human worlds of Iron and Viking Age Scandinavia. *Cambridge Archaeological Journal* 32(2): 331–343. <https://doi.org/10.1017/S0959774321000561>
- Finch, J. & Mason, J. 1991. Obligations of kinship in contemporary Britain: is there normative agreement? *The British Journal of Sociology* 42(3): 345–367. <https://doi.org/10.2307/591185>
- Fiske, A.P. 2020. *Kama Muta: discovering the connecting emotion*. Abingdon & New York: Routledge.
- Forbes, H. 2007. The kinship landscape. In: H. Forbes (ed.) *Meaning and identity in a Greek landscape: an archaeological ethnography*. Cambridge: Cambridge University Press, 286–342. <https://doi.org/10.1017/CBO9780511720284.010>
- Fowler, C. 2022. Social arrangements. Kinship, descent and affinity in the mortuary architecture of Early Neolithic Britain and Ireland. *Archaeological Dialogues*, 29(1): 67–88. <https://doi.org/10.1017/S1380203821000210>

- Gillespie, S.D. 2000. Beyond kinship. An introduction. In: R.A. Joyce & S.D. Gillespie (eds) *Beyond kinship. Social and material reproduction in house societies*. Philadelphia: University of Pennsylvania Press, 1–21.
- Goldberg, H. 2003. *Jewish passages: cycles of Jewish life*. Berkeley and Los Angeles: University of California Press.
- González-Ruibal, A. 2006. House societies vs. kinship-based societies: an archaeological case from Iron Age Europe. *Journal of Anthropological Archaeology* 25 (2006): 144–173.
- Haggrén, G. 2015. Keskiajan arkeologia. In: G. Haggrén et al. (eds) *Muinaisuutemme jäljet. Suomen esi- ja varhaishistoria kivikaudelta keskiajalle*. Helsinki: Gaudeamus, 367–536.
- Hakamäki, V. 2018. *Seeing behind stray finds: understanding the Late Iron Age settlement of Northern Ostrobothnia and Kainuu, Finland*. Oulu: University of Oulu.
- Haraway, D.J. 2016. *Staying with the trouble: making kin in the Chthulucene*. Durham, NC: Duke University Press.
- Hymylä, J. 2004. Rituaalit ja polttokenttäkalmistot. Teoreettista ja metodologista pohdintaa. *Muinaistutkija* 2/2004: 38–50.
- Johnson, K.M. & Paul, K.S. 2016. Bioarchaeology and kinship: integrating theory, social relatedness, and biology in ancient family research. *Journal of Archaeological Research* 24: 75–123. <https://doi.org/10.1007/s10814-015-9086-z>
- Johnston, R. 2020. *Bronze Age worlds. A social prehistory of Britain and Ireland*. London: Routledge.
- Joyce, R. 2000. Heirlooms and houses: materiality and social memory. In: R.A. Joyce & S.D. Gillespie (eds) *Beyond kinship. Social and material reproduction in house societies*. Philadelphia: University of Pennsylvania Press, 189–212.
- Jussen, B. 2000. *Spiritual kinship as social practice: godparenthood and adoption in the early Middle Ages*. Newark and London: University of Delaware Press and Associated University Press.
- Karvonen, J. 1998. Deliberately damaged objects in Iron Age cremation cemeteries. With reference to the objects from the cremation cemeteries of Ylipää in Lieto and Päiväniemi in Lempäälä. *Fennoscandia archaeologica* 15: 3–13.
- Kertzer, D.I. 1991. Household history and sociological theory. *Annual Review of Sociology* 17: 155–179.
- King, J.M. 2004. Grave-goods as gifts in early Saxon burials (ca. Ad 450–600). *Journal of Social Archaeology* 4(2): 214–238. <https://doi.org/10.1177/1469605304041076>
- Kuusela, J.-M. 2018. Food and tension: feasting as means to alleviate social tension in the fourteenth–fifteenth century trading places of the Bothnian Bay region. *World Archaeology*: 50(2): 323–336. <https://doi.org/10.1080/00438243.2018.1494625>
- . 2012. Style as distinction – burials reflecting distinction and the development of social stratification of the Iron Age elites of Southern Ostrobothnia, Finland. In: T. Äikäs et al. (eds) *Archaeology of social relations: ten case studies by Finnish archaeologists*. Oulu: University of Oulu, 155–180.
- Laidoner, T. 2020. *Ancestor worship and the elite in Late Iron Age Scandinavia: A grave matter*. Abingdon and New York: Routledge.
- Lang, V. 2011. Traceless death: missing burials in Bronze and Iron Age Estonia. *Estonian Journal of Archaeology* 15(2): 109–129.
- Lawrence, S. 1999. Towards a feminist archaeology of households: gender and household structure on the Australian goldfields. In: P.M. Allison (ed.) *The Archaeology of household activities*. London: Routledge, 121–141.

- Leach, J. 2019. Kinship and place: the existential and moral process of landscape formation on the Rai Coast of Papua New Guinea. In: S. Bamford (ed.) *The Cambridge handbook of kinship*. Cambridge: Cambridge University Press, 211–230. <https://doi.org/10.1017/9781139644938.009>
- Lévi-Strauss, C. 1949, *Les Structures élémentaires de la parenté*. Paris: PUF.
- . 1982. *The way of the mask*. Seattle: University of Washington Press.
- Lewis, G. 1994. Magic, religion and the rationality of belief. In: T. Ingold (ed.) *Companion encyclopedia of anthropology*. London: Routledge, 563–590.
- Lund, J. & Arwill-Nordbladh, E. 2016. Divergent ways of relating to the past in the Viking Age. *European Journal of Archaeology*, 19(3): 415–438. <https://doi.org/10.1080/14619571.2016.1193979>
- Moilanen, M. 2008. Miekkojen rikkominen rautakaudella – muutamia teknisiä havaintoja. *Muinaistutkija* 4: 19–33.
- . 2021. *Variations in inhumation burial customs in southern Finland (AD 900–1400): case studies from Häme and Upper Satakunta*. Turku: University of Turku.
- Monroy Kuhn, J. et al. 2018. Estimating genetic kin relationships in prehistoric populations. *PLoS ONE* 13(4): e0195491. <https://doi.org/10.1371/journal.pone.0195491>
- Morgan, L. H. 1871. Systems of consanguinity and affinity of the human family. *Smithsonian Contribution to Knowledge*. Washington DC: Smithsonian Institution.
- Morton, S. G. et al. 2019. Shattered: object fragmentation and social enchainment in the eastern Maya lowlands. *Journal of Anthropological Archaeology* 56 (101108). <https://doi.org/10.1016/j.jaa.2019.101108>
- Muhonen, T. 2008. Something old, something new: excursions into Finnish sacrificial carins. *Temenos-Nordic Journal of Comparative Religion* 44(2). <https://doi.org/10.33356/temenos.4592>
- Parkin, R. 2021. *How kinship systems change: on the dialectics of practice and classification*. New York and Oxford: Berghahn.
- Pihlman, S. 2004. Väestöräjähdyksen historiallisen ajan taitteessa? Voisiko aineistoja tulkita toisinkin? *Aboa* 2002–2003: 47–77.
- Puolakka, H. 2020. Ancestors and additional bones: mixing of burial traditions in Late Iron Age Finland. In: T. Äikäs & S. Lipkin (eds) *Entangled beliefs and rituals: religion in Finland and Sápmi from Stone Age to contemporary times*. Helsinki: Suomen arkeologinen seura, 16–34.
- Raike, E. & Seppälä, S.-L. 2005. Naarankalmanmäki. An IA Complex in Lempäälä, Southern Finland. *Fennoscandia archaeologica* 22: 43–78.
- Raninen, S. & Wessman, A. 2015. Rautakausi. In: G. Haggren et al. (eds) *Muinaisutemme jäljet. Suomen esi- ja varhaishistoria kivikaudelta keskiajalle*. Helsinki: Gaudeamus, 215–368.
- Rawson, B. 1986. The roman family. In: B. Rawson (ed.) *The Family in ancient Rome: new perspectives*. Ithaca, NY: Cornell University Press.
- Read, D. 2015. Kinship terminology. In: D. Wright (ed.) *International encyclopedia of the social & behavioral sciences, 2nd edition*. Amsterdam: Elsevier, 61–66. <https://doi.org/10.1016/B978-0-08-097086-8.53053-0>
- Rebay-Salisbury, K. 2010. Cremations: fragmented bodies in the Bronze and Iron Ages. In: K. Rebay-Salisbury et al. (eds) *Body parts and bodies whole: changing relations and meanings*. Oxford: Oxbow, 64–71.
- Riikonen, J. 2005. Kirkkomäen gotlantilainen miniä. In: V. Immonen & M. Haimila (eds) *Mustaa valkoisella. Ystäväkirja arkeologian lehtori Kristiina Korkeakoski-Väisäselle*. Vantaa: Dark Oy, 223–246.

- Rowlinson, M. 2010. *Real money and romanticism*. Cambridge: Cambridge University Press.
- Sahlins, M. 2013. *What kinship is-and is not*. Chicago, IL: The University of Chicago Press.
- Seiser, G. 2000. On the importance of being the last one: inheritance and marriage in an Austrian peasant community. In: P.P. Schweitzer (ed.) *Dividends of kinship: meanings and uses of social relatedness*. London: Routledge, 92–123.
- Shepherd, D. 1997. The ritual significance of slag in Finnish Iron Age burials. *Fennoscandia archaeologica* 14: 13–22.
- Souvatzi, S. 2017. Kinship and social archaeology. *Cross-Cultural Research* 5(2): 172–195. <https://doi.org/10.1177/1069397117691028>
- Söyrinki-Harmo, L. 1984. Problems of research related to cremation cemeteries in Häme. *Iskos* 4: 112–120.
- Steinsland, G. 2011. Origin myths and rulership. From the Viking Age ruler to the ruler of medieval historiography: continuity, transformations and innovations. In: G. Steinsland et al. (eds) *Ideology and power in the Viking and Middle Ages: Scandinavia, Iceland, Ireland, Orkney and the Faeroes*. Leiden: Brill, 15–68.
- Vai, S. et al. 2020. Kinship determination in archeological contexts through DNA analysis. *Frontiers in Ecology and Evolution* 8. <https://doi.org/10.3389/fevo.2020.00083>
- Vuorinen, J.-M. 2009. *Rakennukset ja rakentajat Raison Ihlassa rautakauden lopulla ja varhaisella keskiajalla*. Turku: University of Turku.
- Wessman A. 2009. Reclaiming the past: using old artefacts as a means of remembering. In: A. Sne & A. Vasks (eds) *Memory, society and material culture*. Riga: University of Riga, 71–88.
- . 2010. *Death, destruction and commemoration: tracing ritual activities in Finnish Late Iron Age cemeteries (AD 550–1150)*. Helsinki: Finnish Antiquarian Society.

# 5

## REVISITING, SELECTING, BREAKING AND REMOVING

### Incomplete and fragmented Merovingian reopened graves in Western Europe

*Astrid A. Noterman*

#### **Introduction**

Historians and archaeologists have long been familiar with the practice of reopening graves across early medieval Europe (5th to 8th centuries CE). From the late 6th century and over a wide geographical area, extending from France to Transylvania, living communities regularly re-engaged with their dead through the reopening of their graves and the removal of a selection of objects (e.g. Klevnäs et al. 2021). Traditionally labelled ‘grave robbery’, these interactions took place in a complex system of exchanges between two worlds not yet codified and explicitly separated by Christianity. Post-depositional burial intrusions have been subjected to rationalising explanations in the past, disconnected from the original funerary rite and usually associated with the greed of barbaric individuals moving from site to site to rob the dead (Noterman et al. 2021:64–65; Noterman & Klevnäs 2022:149–152). From the perspective of archaeology, the practice was approached as a constraint to the understanding of ancient burial rites. Human skeletal remains were disturbed, scattered on the floor of the grave or discarded in the filling of the intrusive pit, thus preventing the reconstruction of the original position of the body. Meanwhile, objects were simply missing, removed from the graves by “these robbers, tomb raiders, who were threatened in vain by the many edicts of [the] first-race kings” (Nicaise 1882:122; translation by the author).

Recent studies show that the integrity of graves is not a prerequisite for their analysis. In other words, a reused, reopened or partially destroyed tomb is as valid a source of information as its intact counterparts, the difference being in the initial questions. The gestures associated with secondary engagement have for the most part been identified and analysed through the scope of new

analytical methods and research questions (e.g. Aspöck 2011; Klevnäs 2013; van Haperen 2017; Zintl 2019; Noterman 2021). The information extracted from these non-verbal interactions with the dead shows the complexity of the interpretation of early medieval reopenings. From one single motivation – robbery – the research has moved to a multi-level scenario that could be understood as a response from a community at a time in its existence when the need to interact and exchange with the dead has proved necessary (Noterman et al. 2021:81). This variety of motivations is visible in the different forms of reopening observed in early medieval cemeteries. While the selective extraction of the artefacts – a commonly discussed feature of reopened Merovingian tombs – has recently been reassessed (e.g. Klevnäs et al. 2021:1017–1018; Noterman et al. 2021:78), the deliberate fragmentation of objects and possibly of bodies remains largely understudied, despite some attempts at revision in the last few years (e.g. Châtelet 2017:179–181; van Haperen 2017:146–147).

This contribution aims to open a new discussion on this specific topic, using the archaeological evidence of the fragmentation and removal of material and human remains to reconsider the practice in light of recent research. Following the presentation of different case studies, this paper will move to a general discussion on the meaning of this uncommon and yet informative practice observed in disturbed graves. Moving away from previous assumptions about deliberate damage to the tombs during the reopening process, the study will show that the practice should not be approached with a disrespectful attitude, but as an integral part of mortuary customs, where the dead and their belongings play an active role in the lives of the living.

### **Furnished graves and reopening**

Early medieval graves are commonly found in burial grounds ranging in size from a few to hundreds of mainly single inhumation graves, oriented broadly east to west and often arranged in loose rows. Merovingian cemeteries are characterised by burial practices with clothed corpses and furnished graves, which have significant geographic and chronological variation in proportions and styles (Halsall 2010; Effros & Moreira 2020). Dress accessories, jewellery and weapons are among the artefacts found with the deceased, most often carried in the manner of the living. The variability of grave assemblages mirrors a multifaceted and complex choice. Personal and family considerations were usually involved in the elaboration of the grave and its contents (Effros 2006: 195). This decision-making process had an impact on the reopening practice, as it was the presence of specific objects that instigated the intrusion and the actions that followed. In this course of events, the meaning of the artefacts for the community and/or the reopeners played an important role, although this is difficult to approach through the scope of the archaeological record and written sources.

Merovingian burial practices are deeply heterogeneous in their expression, and this should be considered in the analysis of post-depositional interventions. Moreover, only a fraction of the grave goods have been preserved over time, with burial structures providing only the physical remains that may have survived natural decomposition and corrosion of their components. Based on the incompleteness of the archaeological assemblages, research has also had to face the variety of interpretations attached to the artefacts. An object may have had a particular connotation – symbolic, emotional powerful – for one burial community and a completely different one, if any, for another, thus adding an increased degree of complexity to the motivations associated with the reopening of graves (Härke 2014).

Early medieval reopened graves share a number of similarities that are relatively well identified in archaeology. Recent studies have shown the recurrent selective process that characterised each reopening, from the targeted graves to the objects taken away (Klevnäs et al. 2021; Noterman et al. 2021:84–85). Grave assemblages are often incomplete; the artefacts may be missing or partially dispersed. Bodies similarly undergo different handling, varying from only a few displaced skeletal elements to the whole skeleton. Missing bones also characterise a number of reopened graves and have been regularly noticed in some areas (Aspöck 2011:307).

The incompleteness of disturbed graves is traditionally associated with a form of violence that has long been attached to the phenomenon. In previous studies, a broken object or a fragmented skeleton could only be understood in the light of a desecrating attitude towards the dead and their memory. Such an approach is far from exclusive to early medieval re-entries and often seems to be associated with cultures where the fragmentation of things does not appear to be abnormal for the period or context (Chapman & Gaydarska 2007:2; Lund 2013:51). The idea is so deeply rooted that the notion of fragmented bodies and objects is often seen as nothing but the result of either accidental breakage, taphonomic processes, or, especially with reopened burials, regardless of their chronological horizon, intentional damage.

The recent revision of the archaeological data nuances this approach of ‘damaged’ Merovingian graves, all the more when considering the usual poor condition of the artefacts, which frequently fell into pieces at the time of the reopening. This made them particularly vulnerable to manipulation and, thus, fragmentation. The disappearance of bones can also be linked to the long time-span between the funerals and the re-entries, as attested by taphonomic studies (Aspöck 2011; Noterman 2021). Their removal for practicality during the course of the intrusion has also been suggested, in particular in Transylvania, where human bones were found strewn between disturbed graves (Dobos 2014:144, 150).

Alongside the expected natural consequences of the intrusions, the possibility of deliberate fragmentation of artefacts might be discussed in specific

cases. Similarly, the incompleteness of bodies cannot systematically be related to secondary activity performed during the reopening, and other reasons should be considered. Studies carried out over the last few years show that some suggestions made in the past may be questionable (e.g. fear of the dead, destruction of an enemy), while other ideas (e.g. dialogue between the living and the dead, legacy tensions) may still be relevant even in the light of modern archaeological methodologies (Aspöck et al. 2020). Explanations for the incompleteness of the grave assemblages are not always satisfactory, and researchers tend nowadays to suggest conscious actions performed by the living during the re-entries. In order to assess the scale of the fragmentation practice in early medieval reopened graves, a new revision of the archaeological data from Merovingian cemeteries excavated in northern France has been conducted. Beyond the recognition of the deliberate fragmentation of bodies and goods, the aim is to (re)open the discussion on activities connected to the reopening practice based on new archaeological methodologies that can be applied to these structures.

## **Fragmentation and incompleteness of reopened graves**

### *Intentional breakage of objects*

Artefacts made of several components are most likely to leave evidence of their initial presence in the graves. The discovery of some fastening elements of a belt, for instance, represents valuable information on the type and state of preservation of the removed object and, by extension, on the chronology and motivation of the re-entry. While corrosion is a satisfactory argument for the large majority of fragmented elements found in reopened graves, it nonetheless does not apply to all the cases recorded. Composition, size and fabrication processes simply make some artefacts difficult to break, even after decades of burial. Moreover, studies have indirectly shown that mostly whole objects, independent of their state of preservation, were collected from the graves. Based on this observation, the identification of deliberate acts of fragmentation is puzzling, especially when the small number of archaeological occurrences contradicts previous assumptions about the destructive nature of the reopening practice.

Located in eastern France, the cemetery of Saint-Vit (6th–7th centuries CE) shows several examples of deliberately fragmented grave goods (Urlacher et al. 2008). The proportion of re-entries at Saint-Vit is important, with 51% of the graves reopened, including 4% with evidence of deliberate fragmentation. The male individual buried in chamber grave 17 was provided with a significant number of grave goods, mainly weapons and dress accessories, largely untouched despite the intrusion (Figure 5.1). The body manipulations are limited and focused essentially on the left part of

the abdomen. One of the most unexpected manifestations associated with the re-entry is the fragmentation of the sword into two pieces discovered in two different locations inside the grave. The upper part of the weapon – handle and blade – was found alongside the left humerus of the individual, whereas the pommel lay several centimetres further down. The bottom half of the sword is simply missing. Based solely on the publication, the original location of the sword is difficult to assess, and it is uncertain whether the weapon was taken out of the grave, broken and reburied at its primary placement or moved to a new spot. No metal remains, artefact fragments or imprints on the ground indicate the removal of any other object during the reopening process.

The deliberate fragmentation and partial extraction of artefacts have been recognised in three other burial structures at Saint-Vit. In grave 24, the incomplete handle of a shield is the only remaining part of the original weapon, and no archaeological evidence of the boss has been found. The body is considerably disordered, and most of the bones have been found in the filling of the grave. Similar to most early medieval reopening of graves, selection of the grave goods was performed during the intrusion: the sword and potentially the belt set were removed in addition to the shield, as evidenced by fragments and residual metallic staining from these objects. Whereas the original deposit of the sword is attested through the presence of oxidised traces on the floor of the grave, the complete absence of the shield is largely unusual in a male grave at Saint-Vit.

The disturbance of the individual buried in large chamber grave 70 was limited to the upper right part of the body. The sword and the belt fitting seem to have been the focus of the reopeners. From the first object, only the pommel was found near the right *os coxae*. Originally composed of three elements, the counter and back plates of the belt set remained after the re-entry, but the buckle was certainly removed at the same time as the sword. Finally, the male individual 159 was partially disturbed, and evidence of a sword can again be assessed through the discovery of a pommel placed against the right humerus of the body. No remains of the belt set have been found inside or in the fill of the grave.

The examples from Saint-Vit show that intentional breakage mainly concerns long-bladed weapons and multipartite belt sets. This observation can be extended to the other cases identified in early medieval disturbed cemeteries, with notably similar attitudes towards the remaining fragments. At Osthouse (France), for instance, the handle of a missing sword, originally placed along the right side of the male individual, has been deliberately moved and (re)deposited in another location inside the grave (grave 54; Châtelet et al. 2009:49). Further north, Martine van Haperen suggests that some incomplete plate-buckles discovered in reopened graves in the Netherlands may have been purposely cut (van Haperen 2017:146–147).

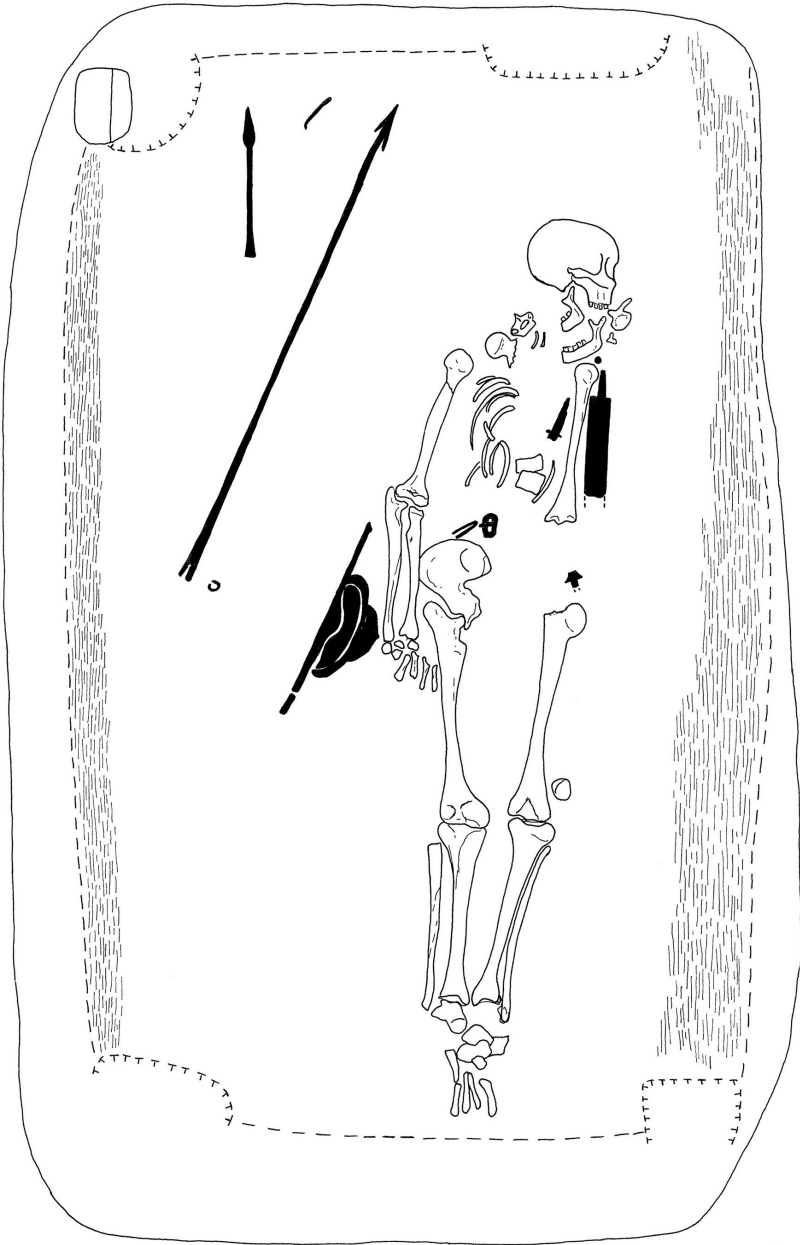

**FIGURE 5.1** Illustration of grave 17 from Saint-Vit (France) with the fragmented and incomplete sword. The upper part of the weapon is lying against the left arm of the individual, while the pommel is located just above the head of the left femur. A set of bones was thrown back over the skull, as partially illustrated here (Urlacher et al. 2008:277).

Establishing whether the act of fragmentation was associated with burial customs or the re-engagement with the dead has different implications for the way to understand societies of that time. Fragmented and incomplete weapons have been recorded in all categories of Merovingian graves, but with a significant difference between the types of contexts considered. The category of weapons involved in the practice varies according to whether or not the grave is untouched. The primary deposition of incomplete seaxes has been recognised at some non-reopened sites, usually with the lower part of the blade kept by the living. The number of cases observed at a single site is often limited; for instance, only two partial seaxes were discovered at Prény (France) in a total of 160 excavated graves, of which 44 had one or several weapons (Figure 5.2) (Frauciel et al. 2018:255–258). On the other hand, the deliberate fragmentation of a sword prior to the inhumation of the deceased does not seem to have been a common practice in early medieval cemeteries. The very few cases mentioned in the literature are not convincing, and no clear examples have been recorded in recent excavations, with the notable exception of reopened graves.

### *Incomplete bodies*

Bone *lacunae* are difficult to precisely quantify in reopened graves. The intrusion has usually implied actions that may have weakened the structure of the bones (e.g. multiple handling, use of tools) or induced ambient changes within the grave that resulted in bone loss. More commonly, non-intentional destructive human activities, soil pressure and acidity and taphonomic processes are some of the natural factors responsible for incomplete skeletons in archaeological contexts. Yet, the regular observation of partial bodies in reopened graves has led researchers to suggest ritual or social reasons behind some osseous defects (Noterman et al. 2021:85), such as the transfer of selected bones to a new burial place (Serralongue & Treffort 1995:112), ancestor worship (van Haperen 2010) or fear of the dead (Noterman 2021:132–133). The intentionality behind the fragmented appearance of some bones is problematic to assess in many cases, in particular for periods with limited complementary sources to support it.

Buried in a chamber grave, the female individual of grave 291 from Vendenheim (France) shows a number of missing bones of the upper body, including complete anatomical sections such as the left upper limb, the shoulder girdle and the thoracic region and this despite good bone conservation (Figure 5.3) (Barrand Emam et al. 2013:258–259). No evidence of the lost bones was found in the backfilling of the structure or in its immediate vicinity. A similar situation is recognised at Illfurth (France) in grave 27, with several sections of the skeleton removed. The skull, the left upper limb, the sacrum and a large portion of the spine are missing, while the rest of

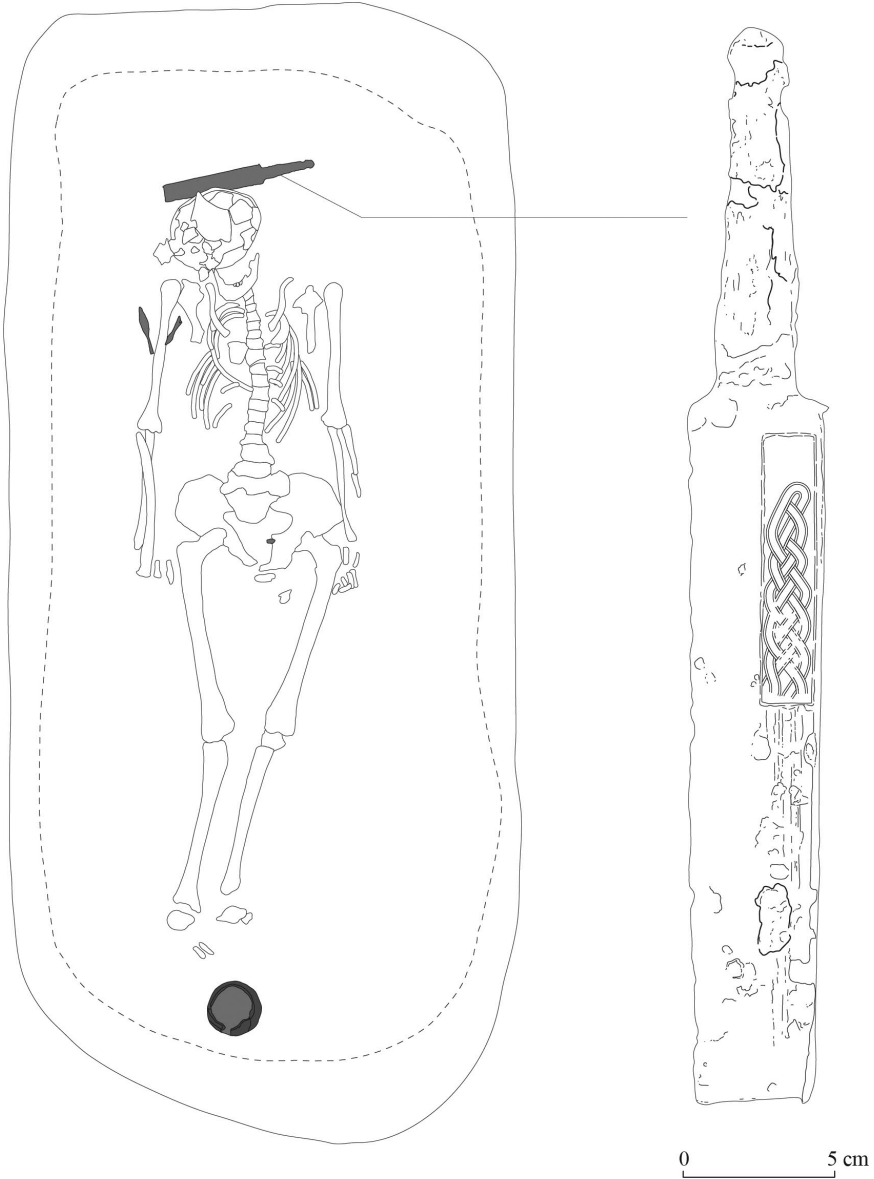

**FIGURE 5.2** Undisturbed male grave 3205 from Prény with an incomplete seax placed at the back of the head of the individual. In addition to the weapon, the assemblage was composed of a ceramic, four iron arrow-heads and a flint (© Inrap, modified by A. A. Noterman).

the body remains untouched and well preserved (Roth-Zehner et al. 2007, vol. 2: 35–36). The incompleteness of bodies in reopened graves is also visible through the recurrent disappearance of specific bones at some sites. At Brunn am Gebirge (Austria), 38% of the disturbed graves contain a body without a skull (Aspöck 2011:307). The proportion of headless bodies at this

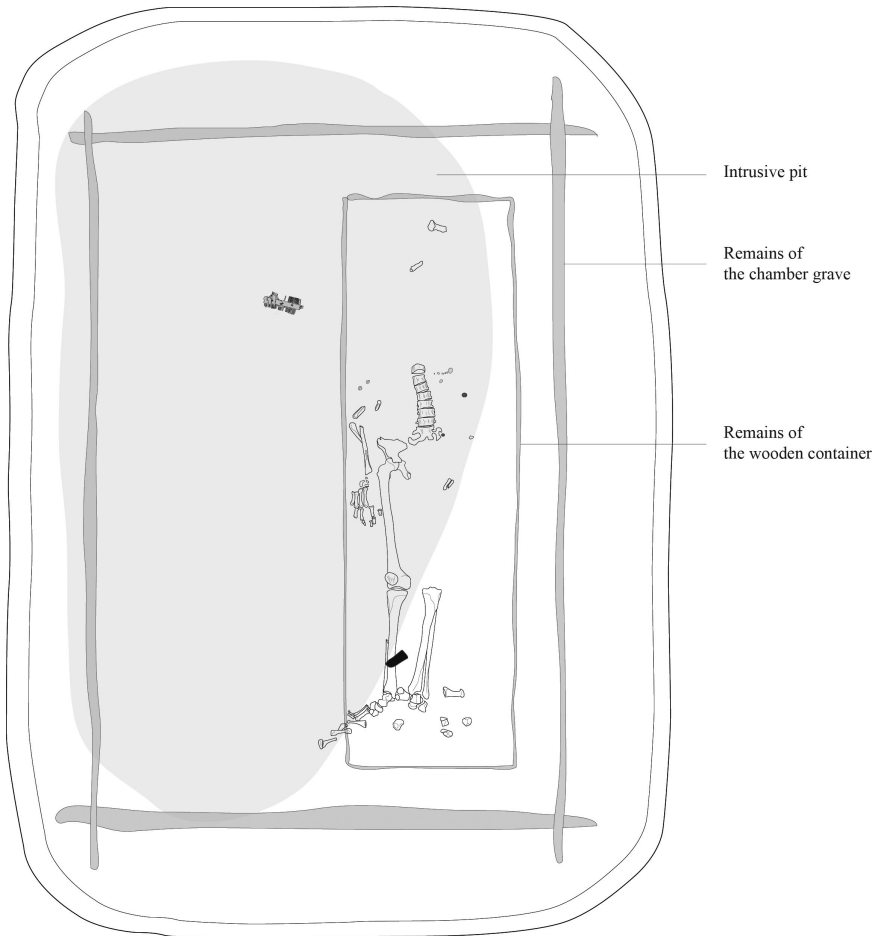

**FIGURE 5.3** Reopened grave 291 from Vendenheim with several anatomical sections missing. From the disturbances, only the left femur has been found several centimetres above the body, probably deposited by the reopeners on the container lid (© Antea archéologie, modified by A. A. Noterman).

site is substantial enough to associate the practice with the re-entry phenomenon rather than a ritual that would have been part of the primary inhumation event. In comparison with other periods, skull manipulations are quite uncommon in Merovingian Western Europe, making Brunn am Gebirge a particularly interesting case.

As with any organic material, bones are particularly sensitive to human manipulation and diagenetic factors. For this reason, the interpretation of their absence in reopened graves is relatively complex and mainly based on the researcher's ability to distinguish between a voluntary or accidental disappearance. A regular issue discussed in relation to reopened graves concerns the fate of the collected skeletal and material remains. At Bülach (Switzerland), one of the shoe buckles worn by the woman in reopened grave 285 was found adapted to the belt fastening of the female individual buried in undisturbed grave 286 (Werner 1953:7). Both graves are from the late 7th century. Similar examples of removal and reuse are mentioned in the archaeological literature but remain exceptional (e.g. Codreanu-Windauer 1997:32; Klevnäs 2013:9–10).

More recently, an excavation conducted at Oegstgeest-Rhijnegeest in the Netherlands has opened the way to a discussion on the destination of the removed bones. In this early medieval trade settlement, a large number of disarticulated human bones were found in various contexts across the site, mainly in the fills of gullies and ditches. The majority of these finds were long bones and skulls. In context 2011–03, a star-shaped configuration of at least five and perhaps six femora and tibia belonging to a minimum of two individuals was discovered at the bottom of a pit (van Haperen 2017:121–125). The bones were joined at the centre at one of their ends, while the other radiated outwards, giving this particulate shape to the formation. Adjacent to this pit, a second pit was excavated, containing selected human bone fragments from at least six individuals, mostly long bones and skull fragments. The osteological analysis of the bones determined that the majority of the skeletal material belonged to male individuals. Only scattered inhumation graves with complete bodies were found at the site, and no archaeological evidence has been recognised of any contemporary cemetery. The bones discovered in non-funerary contexts must have come from a different site, possibly from a reopened burial ground.

## Discussion

Interpretations of artefact recovery from early medieval graves are multiple, mainly due to the huge variation in disturbance levels between cemeteries. In her research into grave reopening in Anglo-Saxon England, Alison Klevnäs argues that inter-personal conflicts may have been played out in some disturbed cemeteries and would explain the varied levels of disturbance observed

in neighbouring burial sites. Moving away from the widespread interpretation that kin or descendants might be involved in the re-entry process (Codreanu-Windauer 1997:33; Müller 2010:59), she suggests that objects were recovered by external actors of the community with the aim of causing a (symbolic and social) loss to the group linked by the ownership (Klevnäs 2015:168–169). Although these interpretations are arguable outside the English examples, they are indicative of the current tendency in reopening studies to focus primarily on the removed artefacts as a whole. Fragmented and incomplete objects are essentially approached through the argument of their poor state, and few are the publications that open the debate about the type of fragment recovered. The breakage of an item by the re-openers may be unintentional, but the retrieval of selected fragments is anything but accidental. The case of the swords is particularly telling, with a selection in favour of a piece of blade instead of the pommel. As a key component of the weapon and highly meaningful during the early medieval period (Brunning 2019:142–143), the pommel is not only purposely left inside the grave, but particular attention is paid to its location in relation to the dead body. Object and individual are thus closely linked in a form that shows parallels with Chapman's fragmentation theory and the notion of enchainment (Chapman 2000); in the present case, there is an chained relationship between the deceased, the fragment and a person amongst the living community.

The fate of the artefacts collected from Merovingian graves has always been a challenging question. The following possibilities are usually considered: (1) objects were moved from the cemetery for a secondary use, distributed to kin or members of the living community or put in a new structure; (2) they came to be part of the funerary assemblage of a newly deceased person at the cemetery or in a neighbouring one; (3) the recovery of artefacts and bones was part of a secondary ritual practice aiming to create new ancestors (e.g. van Haperen 2010:20–28). Considerable effort was made to extract artefacts in poor condition, unlikely to be returned to their previous function, and certainly recognisable because of their particular design features. However, their fate would have been determined by strategies – personal, social and even possibly political – that remain difficult to assess. When it comes to fragments, archaeological data are particularly useful to discuss their post-retrieval use, at least in theory. Pieces of the same artefact may have been distributed between several graves or incorporated into an object buried later with a new individual (see the above-mentioned example of the reconstructed female belt from Bülach). In this sense, a comparative study of disturbed and undisturbed funerary structures may lead to the identification of anomalies in the grave goods assemblage. While this strategy has been applied to prehistoric contexts, it is still marginal for early medieval cemeteries and could be seen as a necessary new step towards a better understanding of the range of practices surrounding the reopening of graves (Châtelet 2017:181).

Michael T. Clanchy's research on changes in legal practices in Medieval England offers an interesting parallel (see the discussion on this point by Chapman, 2000:38). In order to legally seal an agreement, it was common during the Anglo-Saxon period to exchange two parts of an object between the different parties (Clanchy 1993:258–259). Would it be possible to transpose this form of agreement to the specific case of disturbed graves, seeing the removal of a fragment of a sword as a kind of contract between the deceased who originally owned the weapon and its new owner? The selective process that underlies the re-entry practice implies that the collected objects were certainly transferrable between bearers; the different categories of items targeted possess their own personhood and thus the ability to move from one owner to another (Klevnäs 2015:175–176, 179). The nature of this transfer still has to be specified and could have taken many forms, ranging from recovery without the 'consent' of the deceased to the continuation of a dialogue with him/her – the 'contract' being here the expression of one of these long-term discussions between the buried individuals and the living. Similar to the agreement tradition in Anglo-Saxon England, alliances in Merovingian France may have involved the exchange or the gift of belts, as testified in several written sources (Treffort 2002:40; Cartron 2015). The archaeological expression of the practice is possibly illustrated in southwestern Gaul by the incomplete belt sets in the burial assemblage. The social, strategic and memorial significance of the deposit is stressed by the funerary practices in this region, where furnished graves – and consecutive reopening of graves – were far from being the funerary norm. In these graves, buckle fragments “enchained the living and the dead”, creating networks of allegiance (Patrello 2020:930).

Fragmentation does not necessarily require breakage. A body can be fragmented by altering its original structure, 'breaking' the original arrangement of the skeleton or even depriving it of some of its components. The direct interaction with dead bodies was an integral part of the activities that took place during the post-depositional interventions. The recent reassessment of the archaeological evidence for grave reopening shows that disturbed or missing portions of skeletons were primarily a consequence of searching for furnished graves and digging into them. The disturbance of bones was thus mainly a side effect of the intrusions. In fact, the deliberate handling or collection of bones concerns only a limited number of disturbed graves. These manipulations do not necessarily express a form of disrespect for the deceased but rather a new conception of the corpse in the societies of post-Antiquity.

Skeletal elements were usually only removed from the graves in conjunction with the removal of selected (complete or fragmented) artefacts. Unlike grave goods, bone material does not appear to have been the primary aim of the Merovingian re-entries. In this sense, the collection of portions of skeletons following the reopening falls into three categories. (1) The extraction

of bones for practicality to reach the grave goods, their subsequent disposal in the upper layers of the intrusion pit, and then their accidental disappearance (human activities, erosion, etc.). (2) The opportunistic recovery of bones alongside objects. (3) The deliberate collection of selected bones due to their specific attachment to the retrieved artefacts. In a discussion about secondary burials, Ani Chénier argues that in some societies, the collecting of bones may have been practised to transform bodies into artefacts – symbolic objects that could be manipulated as symbols according to the circumstances (Chénier 2009:30). In reopened graves, the systematic association of bone and artefact leads to a rethinking of the definition of human material in these contexts. The timeframe for early medieval re-entry is particularly interesting, with interventions most frequently carried out after soft tissue decay. In these disturbed contexts, recovered bones could thus have been understood or defined by the community that originated the re-engagement with the deceased as good, as ‘objects’ sharing similar power as a sword, a brooch or a belt buckle. Various archaeological and ethnographic studies have reported the symbolic malleability of dead bodies, which can be transformed into a new physical or social identity (Brück 2017:141; Kerner 2018: 278–304; see also Brück this volume; Moilanen this volume). Another possible interpretation is that the bones could have empowered the function of the removed artefacts; one could not function without the other.

Ritual interpretations are a common way to approach the practice of body fragmentation, as discussed previously, although they are more associated with prehistoric than early medieval contexts. Another possibility is the deliberate fragmentation of a body from a mobility perspective. The action of removing bones, possibly based on a selective scheme, could be approached as a change in the deceased, giving his or her remains new social and physical mobility. The conscious choice of waiting for the skeletisation of the buried individual before engaging in post-depositional interactions can be associated with a re-definition of his or her identity. From a living being, the deceased turns into an ancestor (see the discussion on this point by van Haperen, 2010), and his or her remains are transformed into portable elements while embodying a new social function. The excess number of skulls discovered at Szőreg-Téglagyár (Hungary) (Dobos, 2014:150) may be an illustration of this physical and social mobility of human remains – the bones being collected in graves from other cemeteries, maybe curated for a time, and then deposited in a new location as part of a community performance.

## Conclusions

The recovery of artefact fragments and body parts has been archaeologically recorded and recognised as an integral part of the early medieval re-entries.

Yet, the intentional retrieval of fragments stands in contrast to the reopening practice, which relies essentially on the recovery of complete objects. Discussions on the meaning of this selective process are still very much ongoing, although they mainly focus on the relevance of the fragments to those initiating their recovery. Incomplete artefacts and bodies in graves have long been discussed in fragmentation studies, largely in association with prehistoric contexts, but also in relation to more recent periods (Brittain & Harris 2010; see also Röst this volume). Remains from early medieval Europe have rarely figured in the fragmentation debate, and there has been limited engagement in exploring issues such as the destination of the missing parts or the significance of the fragments left in the grave. Yet, these questions have been addressed in other contexts, such as the British and Irish Bronze Age, with the work of Joanna Brück (2017, 2019). The Bülach and Oegstgeest-Rhijngest cases show that a similar approach can be applied to the Merovingian period, although the collection and circulation of fragmented remains certainly had multiple motivations. A key element concerning early medieval Europe is that the decision to fragment and partially remove an object cannot be understood without keeping in mind the diversity and complexity of mortuary practices and beliefs at this time.

The study of disturbed mortuary contexts cannot be disassociated from that of undisturbed contexts, as the reopening of graves is now identified as an integral part of cemetery life. Fragmented swords and belts in reopened graves raise the question of the emotional power of such imperfect fragments, often corroded and sometimes tarnished. At the same time, they reveal other fragmentation practices in Merovingian society, where fragments could forge alliances or formalise successions (e.g. Patrello 2020). The deliberate breakage of objects and bodies did not occur randomly or even as a natural consequence of the intrusion of the living into the sphere of the dead; it was a choice that highlights the richness of disturbed funerary structures in terms of societal and ritual discussions.

### Acknowledgements

I would like to thank H el ene Barrand Emam (Antea Arch eologie, Archim ede-UMR 7044), Marie Frauciel (Inrap) and Fran oise Passard-Urlacher (Laboratoire Chrono-environnement-UMR 6249 CNRS-UFC) for sharing with me the data from the cemeteries of Vendenheim, Pr eny and Saint-Vit. Thanks also to the reviewers for their useful and thought-provoking comments that led to this final version.

This chapter is part of the collective research project « Espaces et pratiques fun raires en Alsace aux  epoques m erovingienne et carolingienne ».

## References

- Aspöck, E. 2011. Past ‘disturbances’ of graves as a source: taphonomy and interpretation of reopened early medieval inhumation graves at Brunn am Gebirge (Austria) and Winnall II (England). *Oxford Journal of Archaeology* 30(3): 299–324. <https://doi.org/10.1111/j.1468-0092.2011.00370.x>.
- Aspöck, E., Klevnäs, A. & Müller Scheefle, N. eds. 2020. *Grave disturbances. The archaeology of post-depositional interactions with the dead*. Oxford: Oxbow. <https://doi.org/10.2307/j.ctv13pk784>.
- Barrand Emam, H. et al. 2013. *Vendenheim, route de la Wantzenau « Entrepôt Atlas-Fly » (Alsace, Bas-Rhin)*. Rapport final d’opération d’archéologie préventive, Antea Archéologie, SRA Alsace.
- Brittain, M. & Harris, O. 2010. Enchaining arguments and fragmenting assumptions. *World Archaeology* 42(4): 581–594. <https://doi.org/10.1080/00438243.2010.518415>
- Brück, J. 2017. Reanimating the dead: the circulation of human bone in the British Later Bronze Age . In: J. Bradbury & C. Scarre (eds) *Engaging with the dead: exploring changing human beliefs about death, mortality and the human body*. Oxford: Oxbow Books, 138–148.
- . 2019. *Personifying prehistory: relational ontologies in Bronze Age Britain and Ireland*. Oxford : Oxford University Press. <https://doi.org/10.1093/oso/9780198768012.001.0001>
- Brunning, S. 2019. *The Sword in early Medieval Northern Europe*. Woodbridge: The Boydell Press. <https://doi-org.ezp.sub.su.se/10.1017/9781787444560>
- Cartron, I. 2015. Variations autour d’un objet: la ceinture des femmes du haut Moyen Âge. In: L. Jégou et al. (eds) *Splendor Reginae. Passions, genre et famille*. Turnhout: Brepols, 129–138.
- Chapman, J. 2000. *Fragmentation in archaeology: people, places and broken objects in the prehistory of South Eastern Europe*. London: Routledge. <https://doi.org/10.4324/9780203759431>
- Chapman, J. & Gaydarska, B. I. 2007. *Parts and wholes: fragmentation in prehistoric context*. Oxford: Oxbow Books.
- Châtelet, M. et al. 2009. *Matzenheim, « Bodengewann » et Osthause « Galgen » (Bas-Rhin)*. Rapport final d’opération archéologique, Inrap, SRA Alsace.
- Châtelet, M. 2017. La réouverture des tombes à l’époque mérovingienne : un acte rituel? In: I. Leroy & L. Verslype (eds) *Communauté des vivants, Compagnie des morts*. Saint-Germain-en-Laye: Afam, 171–182.
- Chénier, A. 2009. Bones, people and communities: tensions between individual and corporate identities in secondary burial ritual. *Nexus* 21: 27–40.
- Clanchy, M.T. 1993. *From memory to written record. England 1066–1307*. Oxford: Blackwell.
- Codreanu-Windauer, S. 1997. *Pliening im Frühmittelalter. Bajuwarisches Gräberfeld, Siedlungsbefunde und Kirche*. Kallmünz: M. Lassleben.
- Dobos, A. 2014. Plunder or ritual? The phenomenon of grave reopening in the row-grave cemeteries from Transylvania (6th–7th centuries). In: M. Gligor (ed.). *Archaeothanatology: an interdisciplinary approach on death from prehistory to the middle Ages*. Alba Iulia: Editura Mega, 135–162.

- Effros, B. 2006. Grave goods and the ritual expression of identity. In: T. F.X. Noble (ed.) *From Roman provinces to medieval kingdoms*. New-York: Routledge, 189–232.
- Effros, B. & Moreira, I. eds. 2020. *The Oxford handbook of the Merovingian world*. Oxford: Oxford University Press.
- Frauciel, M. et al. 2018. *La nécropole de Prény Bois Lasseau. Fouilles TGV Est n°83*. Rapport final d'opération archéologique, Inrap, SRA Grand Est.
- Halsall, G. 2010. *Cemeteries and society in Merovingian Gaul: selected studies in history and archaeology, 1992–2009*. Leiden: Brill Academic Publishers.
- van Haperen, M.C. 2010. Rest in pieces: an interpretive model of early medieval 'grave robbery'. *Medieval and Modern Matters* 1: 1–36. <https://doi.org/10.1484/J.MMM.1.100807>.
- . 2017. *In touch with the dead. Early medieval grave reopenings in the low countries*. Leiden: Universiteit Leiden. <https://doi.org/10.17026/dans-x6b-bvgj>.
- Härke, H. 2014. Grave goods in early medieval burials: messages and meanings. *Mortality*. <https://doi.org/10.1080/13576275.2013.870544>.
- Kerner, J. 2018. *Manipulations post-mortem du corps humain: implications archéologiques et anthropologiques*. Leiden: Sidestone Press.
- Klevnäs, A. 2015. Give and take: grave-goods and grave robbery in the early Middle Ages. In: A. M. Klevnäs & C. Hedenstierna-Jonson (eds) *Own and be owned: archaeological approaches to the concept of possession*. Stockholm Studies in Archaeology 62: 157–188.
- Klevnäs, A. et al. 2021. Reopened graves in the early Middle Ages: extended mortuary customs found across Europe. *Antiquity* 95(382): 1005–1026. <https://doi.org/10.15184/aqy.2020.217>.
- Klevnäs, A.M. 2013. *Whodunnit? Grave Robbery in Anglo-Saxon England and the Merovingian Kingdoms*. Oxford: Archaeopress.
- Lund, J. 2013. Fragments of a conversion: handling bodies and objects in pagan and Christian Scandinavia AD 800–110. *World Archaeology* 45(1): 46–63.
- Müller, K. 2010. *Gräber, Gaben, Generationen: der frühmittelalterliche Friedhof (7. Jahrhundert) von der Fräiebergstrasse in Baar (Kanton Zug)*. Basel: Archäologie Schweiz.
- Nicaise, A. 1882. Le cimetière mérovingien de l'Académie. Commune de Saint-Quentin-sur-Coole (Marne). *Mémoires de la Société d'agriculture, commerce, sciences et arts du département de la Marne* 1880–1881: 117–124.
- Noterman, A.A. 2021. *Approche archéologique des réouvertures de sépultures mérovingiennes dans le nord de la France (VI<sup>e</sup>–VIII<sup>e</sup> siècle)*. Oxford: BAR Publishing.
- Noterman, A.A. & Klevnäs, A. 2022. In search of an acceptable past: history, archaeology, and 'looted' graves in the construction of the Frankish early Middle Ages. In: E. Weiss-Krejci et al. (eds) *Interdisciplinary explorations of postmortem interaction: the uses of dead bodies, funerary objects, and burial spaces through texts and time*. Cham: Springer, 133–165. [https://doi.org/10.1007/978-3-031-03956-0\\_6](https://doi.org/10.1007/978-3-031-03956-0_6)
- Noterman, A.A. et al. 2021. La perturbation des sépultures mérovingiennes est-elle « élémentaire » en archéologie ? Nouveaux regards sur les réouvertures de tombes au haut Moyen Âge en Europe. *Archéologie médiévale* 51: 69–92. <https://doi.org/10.4000/archeomed.39440>.
- Patrello, R.J. 2020. Belt buckles and burials in southwestern Gaul. In: B. Effros & I. Moreira (eds) *The Oxford handbook of the Merovingian world*. Oxford: Oxford University Press, 916–938. <https://doi.org/10.1093/oxfordhb/9780190234188.013.53>

- Roth-Zehner, M. et al. 2007. *Illfurth, lieu-dit Buergelen (Alsace, Haut-Rhin)*. Rapport d'archéologie préventive, Antea Archéologie, SRA Alsace.
- Serralongue, J. & Treffort, C. 1995. Inhumations secondaires et ossements erratiques de la nécropole des Combes, à Yvoire (Haute-Savoie). Analyse archéologique et questions historiques. *Pages d'archéologie médiévale en Rhône-Alpes 2*: 105–118.
- Treffort, C. 2002. Vertus prophylactiques et sens eschatologique d'un dépôt funéraire du haut Moyen Âge: les plaques boucles rectangulaires burgondes à inscription. *Archéologie médiévale 32*: 31–53.
- Urlacher, J.-P. et al. 2008. *Saint-Vit, « Les Champs Traversains » (Doubs). Nécropole mérovingienne, VI<sup>e</sup>–VII<sup>e</sup> siècle ap. J.-C. et enclos protohistorique, IX<sup>e</sup>–V<sup>e</sup> siècle av. J.-C.* Besançon: Presses universitaires de Franche-Comté.
- Werner, J. 1953. *Das alamannische Gräberfeld von Bülach*. Basel: Birkhäuser Verlag.
- Zintl, Z. 2019. *Frühmittelalterliche Grabräuber? Wiedergeöffnete Gräber der Merowingerzeit*. Regensburg: Stadt Regensburg.

# 6

## PARTED PAIRS

### Viking Age oval brooches in Britain, Ireland, and Iceland

*Frida Espolin Norstein*

#### Introduction

The concept of fragmentation in archaeology has demonstrated the significance of deliberately broken objects. Studies of fragmentation have shown how pieces of a broken whole could be distributed and deposited, creating and manifesting social ties and links with the past (Chapman 2000). This paper is only tangentially concerned with broken things, but it is concerned with parts and wholes and the significance of the relations between these (Chapman & Gaydarska 2007). The object under consideration is a type of brooch from the Viking Age called an oval brooch. These brooches were very common and worn all over the Viking world for a long period of time. They were also used in a highly particular way: worn as a matching pair, one on either side of the upper chest, with a type of female costume called a strap dress, where the brooches were used to secure together straps from the front and back pieces at the upper chest (Figure 6.1; Hägg 1974:58; Ewing 2006:32–39).

The domed shape and recessed pin of the brooch meant that it was very well suited for this type of use, as the straps would pull on the brooch from either direction, causing it to lie flat. This shape, as well as the large size of the brooches, would have meant that they were considerably less suited for other types of use, such as pinning folds of material together (Ewing 2006:25). The connection between oval brooches and strap dresses has implied that the two have become more or less inseparable in archaeological interpretations. In Britain, Ireland, and Iceland, which are the areas under consideration in this chapter, the discovery of an oval brooch is often taken as an indication of the presence of a pair of brooches, a strap dress, and, by extension, the presence



**FIGURE 6.1** Illustration of a strap dress with oval brooches (illustration: Frida Espolin Norstein).

of a Scandinavian woman. Understanding an oval brooch as a part of this whole entails that the breaking up of pairs and the individual brooches' use before and after separation can be cast in a framework inspired by fragmentation and enchainment. As discussed by John Chapman (2000:46), there is clearly an analogous relationship between a set with its parts and a complete object with its fragments. I believe fragmentation theory provides a useful

framework for discussing the oval brooches; it acknowledges how they were parts of a set while also highlighting their significance as individual objects. By focusing on the brooches that have evidently been parted from their original set, this chapter will examine how and why pairs of brooches were split apart and how they would function in their new context.

### *Production*

Oval brooches are among the most characteristic finds of the Viking Age. They are fairly large, generally about ten centimetres in length, with a domed oval shape and decorated with zoomorphic motifs (Figure 6.2) (Petersen 1928; Jansson 1985). The earliest oval brooches date from the Merovingian/Vendel period (c. 550–800 CE), though they became far more common and standardised from the Viking period onwards (Jansson 1985). Their main period of use was from the late 8th century to the mid-to-late 10th century, although they appear to have gone out of use earlier in certain areas than in others (Kershaw 2013:224–227). The oval brooches have been found all over Scandinavia, as well as in the Scandinavian settlements from Iceland to

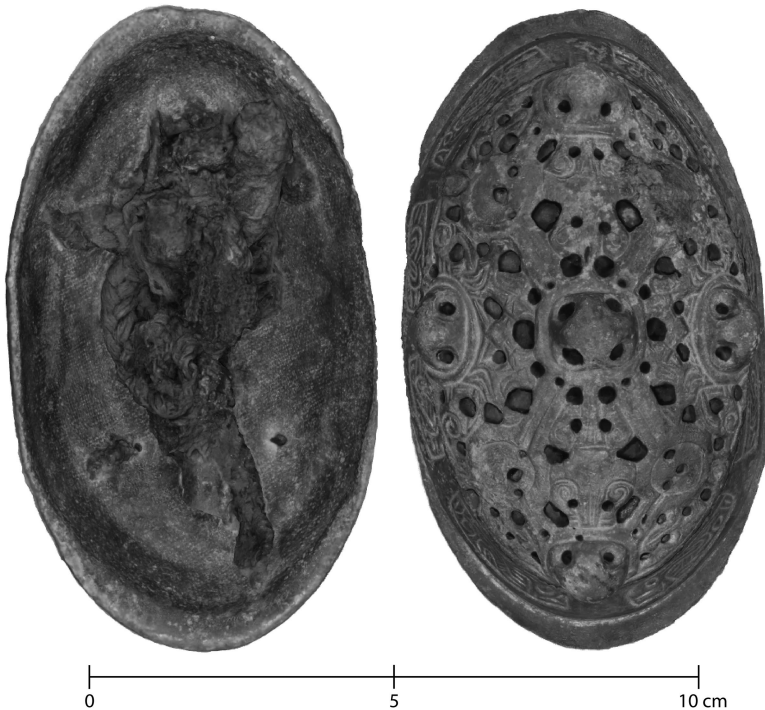

**FIGURE 6.2** Oval brooch (5960) from Dalvík (illustration by the author & by kind permission of the National Museum of Iceland).

Russia, and they demonstrate a far-reaching and long-lasting mode of dress (Petersen 1928; Paulsen 1933; Jansson 1985).

Although the overall shape of the brooches remains constant, they vary somewhat in size, with the earliest brooches generally being smaller; from the 10th century onwards, double-shelled brooches are the most common. The décor of the brooches is fairly standard, especially from the 9th century onwards, making it possible to divide them into overall types. Evolutionary typologies for the oval brooches were established and reworked in the 19th and 20th centuries and are generally agreed upon (Montelius 1873, 1877; Rygh 1885; Petersen 1928; Jansson 1985). These artefacts were produced through mechanical copying (Jansson 1981, 1985). A single model, which could be an already existing brooch, was used to make a master mould from which several more or less identical wax models could be made. The wax models were in turn used to produce moulds in which the finished brooches were cast (Brinch Madsen 1976, 1984; Jansson 1981, 1985; Lønborg 1994, 1998). The end result would be brooches with a very high degree of similarity, which is evident in the archaeological record; brooches from geographically distant findspots can be more or less identical. This mode of production also implies that an already old brooch could be used as a model to produce several new copies, meaning that the typology cannot easily be equated with chronology (Jansson 1981; Fuglesang 1987). The question of where the oval brooches were produced is not clearly settled. Most of the evidence suggests that they were the result of large-scale production in the early urban centres in Scandinavia, particularly in Ribe and Birka, but there is some evidence of small-scale rural production (Dunér & Vinberg 2006:20–21; Feveile & Jensen 2006; Ambrosiani 2013; Pedersen 2016:264–265). For the purpose of the present chapter, the main points to note about the production of oval brooches are that brooches produced as pairs are likely to have been almost identical in appearance and that there is no evidence to suggest that they were produced in Britain, Ireland, or Iceland.

### *Oval brooches in Britain, Ireland, and Iceland*

In the areas of Viking settlement in Britain, Ireland, and Iceland, the oval brooches have been seen to represent the burials of Scandinavian women (see Harrison 2008:118–125 for a discussion). As with Viking graves more generally, they were mainly used to discuss the scale and extent of Viking expansion, at least until around the end of the last millennium (Norstein 2020:7–16). Subsequently, questions about identities and gender roles have received significant attention, and the oval brooches are often included in these discussions as they are regarded as so closely tied up with both female gender identity and Scandinavian ethnicity (e.g. Hayeur Smith 2004; McGuire 2010; Kershaw 2013). Individual brooches have essentially been

seen as interchangeable. They are taken to indicate the presence of a Scandinavian woman and are treated as having definite and easily understood meanings (Norstein 2020:14–15). Understanding an oval brooch as a part of a whole related to Scandinavian female dress is in many ways understandable and also useful. The two are intimately associated. As a group of artefacts, oval brooches were used in a fairly standardised way. They would presumably have been associated with female Scandinavian identities, as they were used by women in Scandinavia and the various Scandinavian settlements for a period lasting around 150 years. Although they were not necessarily always used by Scandinavian women, they were still citing female Scandinavian identities. In addition to their simply functional aspects, it is the citational properties of oval brooches as a group that have been regarded as the reason for their use in Viking Age burials in Britain, Ireland, and Iceland (Norstein 2020:96–98).

The almost exclusive focus on the oval brooches as representatives of a whole has obscured how they would have functioned apart from this context. These are also individual artefacts with distinct use-lives, meaningful because they exist in a network of relations with people, things, and events – past, present, and future (Kopytoff 1986; Gosden & Marshall 1999; Chapman 2000; Joy 2009). The way an oval brooch is used is not predetermined but is dependent on how these artefacts have previously been used, by what people, and in what contexts. To what extent is this visible in the corpus? What evidence is there that oval brooches were significant as individual artefacts rather than as part of a set? In order to address these questions, I will examine the oval brooches from Britain, Ireland, and Iceland that have not been deposited as matching pairs. I will present the material consisting of non-matching pairs, single brooches, and brooch fragments before discussing how and why pairs of brooches were broken up and reassembled in new constellations.

## Material

I have identified 145 oval brooches: 62 from Scotland, 49 from Iceland, 19 from Ireland, and 15 from England (Norstein 2020:41). The oval brooches discovered in the western settlements are, for good reason, generally assumed to have been grave goods. In many cases, this is definite as they were discovered with skeletal remains, and in others, it is highly likely based on the context in which they were found. However, it is a significant problem for anyone wanting to study these brooches that their finding circumstances are frequently very poorly recorded (Norstein 2020:108). Although there are extant descriptions of finding circumstances in some instances, in other cases, the brooches are only recorded as they entered the collections of museums, at times with only a vague provenance (e.g. Anderson 1874). Deposition of brooches for reasons other than burials cannot be excluded, but it is

likely that finds of pairs, and presumably the finds of most complete single brooches, are representative of graves. Accidental loss of complete brooches seems unlikely due to the size and shape of the brooches as well as their function as dress fasteners. The brooches themselves are in various states of preservation. Quite a number are lost; others are damaged or suffering from corrosion (Norstein 2020:41–64).

The vast majority of the oval brooches – 137 – are assumed to be from funerary contexts, while the rest are stray finds of fragmented brooches. 106 of the brooches from presumed burials were discovered as pairs (Norstein 2020:64–67). We are rarely able to say with any degree of certainty exactly what artefacts were in the grave and how they were used, and it is therefore possible, and perhaps also likely, that a number of the single brooches were originally deposited as pairs.

### *Non-matching pairs*

Out of the 53 pairs of brooches from the western settlements, 28 formed matching pairs, and 9 were non-matching. Not all non-matching pairs are equally different, however. The definition I have employed is that the brooches are too dissimilar to have been made as copies from the same master mould. Whether the remaining 16 pairs were matching or not has been impossible to determine for several reasons: brooches have been lost, the level of corrosion has increased, or I have been unable to examine the brooches in sufficient detail. The large number of indeterminably matching pairs makes it difficult to ascertain how common the use of non-matching brooches was, although on the present evidence, we can say that at least 17% of the pairs, and possibly more, were non-matching.

Of the nine non-matching pairs, five are from Scotland, two are from Iceland, and two are from England (Table 6.1). No non-matching pairs have been discovered in Ireland, though it is possible that some of the very poorly recorded single brooches may have formed non-matching sets.

In seven out of the nine cases, remains of textile inside the brooches and/or their placement clearly indicate that they were worn by the deceased at the burial. In the grave in Valbjófsstaðir, Iceland, the brooches are said to have been found at the waist of the deceased. The discovery was made around 1800 by the local priest who assumed the brooches had been used to attach a belt (Ormsson in Eldjárn & Friðriksson 2016:224–225). It is difficult to ascertain whether or not the brooches had actually been placed at the waist or if they had shifted after deposition. It is also possible that the finder was mistaken due to the crouching position of the body. In the other six instances, the brooches are likely to have been placed on the upper chest and worn with strap dresses.

In one of the remaining two instances, from Ballinaby in Scotland, the record only states that “a grave was discovered under a large standing stone

**TABLE 6.1** Non-matching pairs of brooches from the western settlements. Museum numbers are in brackets. NMS: National Museums Scotland. BM: British Museum. NMI: National Museum of Iceland. NMD: National Museum of Denmark. DMAG: Doncaster Museum and Art Gallery (Table: Frida Espolin Norstein)

		<i>Brooch 1</i>	<i>Brooch 2</i>
		<i>Type and ID</i>	<i>Type and ID</i>
Scotland			
	Reay	P51A1 (NMS X.IL 334)	P51B1 (NMS X.IL 335)
	Westerseat	P51B1(2?) (NMS X.IL 217)	P51G (NMS X.IL 218)
	Cnip	P51C2 (NMS X.IL 799)	P51C1 (NMS X.IL 800)
	Ballinaby	P51F (NMS X.IL 215)	P51E (NMS X.IL 216)
	Pierowall	P37.10 (BM 1987,0510.1)	P37.12 (BM 1987,05.110,2)
Iceland			
	Daðastaðir	P51B2 (NMI 15691a)	P51B2 (NMI 15691b)
	Valþjófsstaðir	P51B1 (NMD DCLIX)	P51B2(1?) (NMD DCLX)
England			
	Leeming Lane	P51F (NMS X.IM1)	P51B1 (?)
	Adwick le Street	P37.3 (DMAG)	P37.12 (DMAG)

in the year 1788. There is no precise record of the circumstances beyond the fact that a pair of oval bowl-shaped brooches were found in it” (Anderson 1883:38). In the last case, from Reay in Scotland, it has been argued that the brooches were placed back-to-back, with the hollow undersides facing each other (Batey 1993:152). The description of the placement of the brooches is not definite, however, and there are textile remains inside at least one of the brooches, suggesting it was attached to clothing (Jørgensen 1992:215). In my opinion, the description that says the brooches were placed face-to-face refers to the domed fronts of the brooches facing each other. The Reay grave is one of the very few crouched burials (Curle 1914:295), and it is possible that the deceased had been placed on one side. If the brooches had been used with a strap dress, they may well have ended up face-to-face as a result of post-depositional taphonomic processes.

### *Single brooches and brooch fragments*

As mentioned, the number of single brooches is difficult to determine as the circumstances of discovery and recovery are often unclear, and in many cases,

there may originally have been more than one brooch present. Although 40 brooches have been discovered without a counterpart, there are really only two instances where we can say with some degree of certainty that only a single brooch was actually deposited (Norstein 2020:87–90). These cases are both from Iceland: Dalvík and Reykjasel. Both sites were excavated by Daniel Bruun in the first decade of the 20th century, and unlike most of their contemporaries, they were fairly well recorded. This is especially the case at Dalvík, where a cemetery of thirteen graves (a fourteenth grave was later discovered) was discovered in 1908 and excavated the following year (Bruun & Jónsson 1910). Only one of the graves contained an oval brooch. It was discovered lying horizontally at the neck of the individual, and it was specifically noted that there was no reason to suppose that another brooch had been present (Bruun & Jónsson 1910:95). There were textile remains inside the brooch, and although these remains did take the form of a strap, it is still likely to have been used to attach a cloak or something similar (Figure 6.2). At Reykjasel, which was excavated in 1901, Bruun arrived after the body had been uncovered and some of the grave goods, including the oval brooch, had been removed (Bruun 1903). Bruun (1903:18) suggested that the brooch had been used to fasten a tunic or cloak at the waist, a suggestion supported by metal staining on the lower ribs (Steffensen 1966:45). There were textile remains still present inside the brooch when it was recovered, and this time clearly not in the form of a strap. Considering the way the brooch was attached, it could have functioned more or less as a belt clasp (Bruun 1903:18).

There is a final case of an oval brooch that appears to have been deposited without its counterpart. This is from the cemetery of Cumwhitton in England, which was discovered in 2004 and excavated shortly thereafter (Paterson et al. 2014). Three oval brooches were discovered; two came from the same burial, known as grave 1, and formed a matching set. A third was discovered as fragments in the plough soil. The excavators presented different suggestions as to which grave this brooch had belonged to, although grave 2 was regarded as the most likely. The reason was that it did not already contain oval brooches, at the same time as the rest of the grave goods were indicative of a female grave (Paterson et al. 2014:46). I would suggest that the brooch is more likely to have been part of grave 1, as it was discovered significantly closer to this grave than any of the others and also in association with other fragmented artefacts, parts of which were discovered almost immediately next to grave 1 (Norstein 2020:85). This would indicate that there were three brooches in the same grave, two of which were forming a pair and a third used in a different way. The presence of three oval brooches in a single grave is not unknown in Scandinavia. Burials at Nes (T13711), Sårheim (B10975), and Grande (T17679) in Norway all contained three brooches. In all cases, these consisted of a pair of matching brooches, with the third being of a

significantly earlier type. This is also the case at Cumwhitton. The pair of brooches belong to the most common type of 10th-century brooches (P51), whereas the third brooch belongs to the so-called Berdal type and was probably produced in the early 9th century (Norstein 2020:85–86). The placement of the oval brooch pair from Cumwhitton suggests that they were worn by the deceased. It is impossible to say how the third brooch had been used due to its disturbance by ploughing. It may have been affected by fire, which has not been observed in any of the other grave goods from Cumwhitton. On the other hand, the marks could potentially be the effect of corrosion (Paterson et al. 2014:46).

In addition to these complete single brooches, fragments of oval brooches have also been found. Some of these are stray finds discovered as a result of metal detecting. In other cases, it is also unclear if the fragments really came from burials. If they were, how much of the brooch was originally deposited, and did the fragmentation happen pre- or post-deposition (Norstein 2020:92–93)? From one site, at Brú in Iceland, only a small fragment of an oval brooch was recovered, along with a number of other artefacts (Vigfússon 1881). The grave was not excavated by professionals, and it is possible that other fragments were present. However, several small beads and iron fragments were recovered, suggesting that other remains of the oval brooch (or brooches) ought to have been recorded if present.

### *How and why were pairs parted?*

Oval brooches were, in all probability, both made and acquired as matching sets. Nevertheless, as demonstrated above, a significant number of brooches were clearly used in burials alone or with a brooch of a different type, or at least one created from a different master mould. At some point, a matching set of brooches was split apart. What could be the reasons for this uncoupling of oval brooches? One explanation is that this could be the result of the destruction or loss of one brooch from an original pair. As already mentioned, I believe that the size and function of the brooches suggest that accidental loss must have been rare, but there are a number of brooches with obvious signs of repair, indicating that brooches could certainly have become unusable (Norstein 2020:48–64). In a scenario where one brooch in a pair was destroyed, acquiring a second brooch, even one of a different type, could have been considered expedient. As strap dresses required two brooches, the dress would have become more or less unusable without a second brooch. There is some evidence in favour of such an interpretation. The non-matching brooches discovered together are never of very dissimilar types (see Table 6.1). In some cases, there are obvious differences in the framework and décor of the brooches, but it is far from certain that this would be immediately noticeable when the brooches were worn. The similarities

of non-matching brooches used as pairs could indicate that people wanted brooches as close in appearance as possible. However, all the non-matching pairs of brooches are of either the most common types in the 9th or 10th centuries. It is possible that non-matching brooches were similar in appearance, not because this was necessarily important but because the most common brooches at the time were fairly similar.

Loss and destruction are possible reasons for pairs of brooches to be separated and used as single brooches or non-matching sets. However, some of the examples presented in this chapter demonstrate that oval brooches were not used in burials only because of their function with strap dresses. The single brooches from Dalvík and Reykjasel were certainly attached to textiles in the burials and therefore presumably worn, but evidently not with strap dresses. It is possible that the non-matching pairs from Valþjófsstaðir had been placed at the waist of the individual rather than worn with a strap dress. A similar and stronger case can be made for a matching set of brooches discovered at Álaugarey (Þórðarson 1936:32–34). There are, of course, cases where the brooches were not worn by the deceased at all. Although I do not see the non-matching pairs at Reay as an example of this, there are other instances where brooches were clearly placed back-to-back in the grave: at Claughton Hall in England (Edwards 1969) and Ballyholme in Ireland (Cochrane 1906). The brooch fragment from Brú is unlikely to have been worn by anyone in the grave either, and there are presumably reasons beyond functionality explaining why it was used as grave goods. It is unclear how the brooch from Cumwhitton was used in the burial, but if we accept the interpretation presented here that it was from grave 1, it was clearly not used to fasten a strap dress.

Certain brooches were evidently treated in unusual ways. The above examples demonstrate that oval brooches had roles in burials that went beyond their function as dress fasteners. How come? Why are the individual brooches significant beyond their function? In order to address these questions, it is necessary to pay more attention to the ways in which oval brooches were used. A close examination of the oval brooches from Britain, Ireland, and Iceland has demonstrated that wear and repair are not unusual (Norstein 2020:48–64). The traces of use-wear, in particular, demonstrate that the brooches must have been worn on a fairly regular basis. This means that oval brooches and strap dresses were certainly not only used for burials but are likely to have formed part of everyday dress for certain women in Scandinavia and the Scandinavian settlements. The brooches are likely to have been personal belongings, and an intimate connection between oval brooches and specific individuals is hinted at by their frequent employment in dressing the deceased (see Joy 2009:550; Arnold 2016:842; Klevnäs 2016:461). The repeated use of specific brooches in everyday dress means that it is likely that the brooch would have become capable of evoking remembrances of that

specific person and the types of situations in which they were worn (Jones 2007:66; Norstein 2020:72–74).

The age of the oval brooches is often difficult to determine because they are generally the only diagnostic artefacts in the grave. In some cases, however, such as in the already mentioned Cumwhitton grave, we find brooches that were of considerable age when deposited (see Norstein 2020:69–71). The third Cumwhitton brooch might well have been around a century old, and a similar age can be suggested for a matching pair from Clibberswick in Shetland (Norstein 2020:70). These brooches clearly belonged to more than one individual, and they are likely to have been heirlooms. As such, the brooches would have formed a physical link with previous generations and could have been connected to memories of family history (Lillios 1999; Gilchrist 2013; Norstein 2020:77–79). Oval brooches discovered in Britain, Ireland, and Iceland would all have been imported from Scandinavia, and the variations in type and quality suggest that many are likely to have arrived as part of the dress of female migrants. The family stories connected with the oval brooches from the western settlements are therefore also likely to have involved stories of migration and family origins. A single brooch could have evoked memories of migration, family history, and the specific individual who was primarily associated with the brooch.

In light of the above discussion, it is noticeable that a number of brooches used in unusual ways often show signs of having had extended use-lives. This is most evident in the case with the third brooch from Cumwhitton, but there are also other examples. The single brooch from Dalvík had been repaired, and it is possible that the one from Reykjasel was as well (Norstein 2020:87–90). The latter also demonstrates obvious signs of use (Figure 6.2). These three single brooches at least were evidently regarded as individual brooches and not just as parts of a whole; this was most likely a consequence of their long use-lives and connections with people in the past.

The wear and repair we see on brooches, the different lengths of time they were in use, and the differences in how they were used in funerary rites all point to the individuality of the brooches. Through their use, the brooches were connected to different people and events, and through their use, they could have evoked remembrances of these past people and events. In this sense, oval brooches were not interchangeable. Destruction or loss can certainly not be ruled out as reasons for pairs of brooches to have been parted, but there are also other possibilities. Pairs could have been parted at the death of an individual as a way of maintaining a physical connection with the deceased and the past. It is also possible that brooches were traded and that they could have functioned as physical manifestations of friendships or alliances (Norstein 2020:74–79). The oval brooches were significant as objects with their own sets of relations and potential for evoking remembrances, and

this suggests that splitting pairs and using the individual brooches in new constellations would also have been highly meaningful practices.

## Conclusions

The oval brooches from Britain, Ireland, and Iceland are most commonly discovered as part of a whole, consisting of a matching pair of brooches worn with a strap dress. However, this chapter has demonstrated that they also have significance as parts beyond this constellation. I have demonstrated that there are a number of oval brooches from Britain, Ireland, and Iceland that were split from their original set and either worn with a non-matching brooch or used in entirely different ways in the burials. Their use in funerary settings was not only due to their functionality; in certain cases, they seem not to have served any practical function at all.

The brooches could still be seen as referring to a whole, consisting of a pair of brooches and, by extension, female Scandinavian identity. This could be part of the reason why the brooches retained their significance. However, individual brooches had individual use-lives and may well have been treasured because of their connections with past people and events. As artefacts intimately connected with individuals who are likely to have worn them frequently over an extended period of time, an oval brooch would have been a powerful agent for evoking remembrances of the past. The splitting up of and the retaining of specific brooches and even brooch fragments, as well as their eventual deposition in burials, could have been an important strategy for both creating and materialising ties between people, places, things, and times. By understanding the brooches as individual parts, but at the same time as relating to a whole, it becomes possible to create much more vibrant and diverse narratives of their functions and meanings in Viking Age society.

## References

- Ambrosiani, B. 2013. *Excavations in the Black Earth 1990–1996: stratigraphy. Vol. 1 (Part one: the site and the shore, part two: the bronze caster's workshop)*. The Birka Project. Stockholm: Riksantikvarieämbetet.
- Anderson, J. 1874. Notes on the relics of the Viking Period of the Northmen in Scotland, illustrated by specimens in the museum. *Proceedings of the Society of Antiquaries of Scotland* 10: 536–594.
- . 1883. *Scotland in pagan times: the Iron Age*. Edinburgh: D. Douglas.
- Arnold, B. 2016. Belts vs. blades: the binary bind in iron age mortuary contexts in Southwest Germany. *Journal of Archaeological Method and Theory* 23(3): 832–853. <https://doi.org/10.1007/s10816-016-9289-8>
- Batey, C.E. 1993. The Viking and Late Norse graves of Caithness and Sutherland. In: C.E. Batey et al. (eds) *The Viking age in Caithness, Orkney and the North Atlantic: selected papers from the proceedings of the eleventh Viking Congress, Thurso and*

- Kirkwall*, 22 August-1 September 1989. Edinburgh: Edinburgh University Press, 148–164.
- Brinch Madsen, H. 1976. Specialist i spænder. *Skalk* 4: 12–15.
- . 1984. Metal-casting. In M. Bencard (ed.) *Ribe Excavations 1970–76*, Vol 2. Esbjerg: Sydjysk Universitetsforlag, 15–189.
- Bruun, D. 1903. Nokkrar dysjar frá heiðni, eftir kapt. *Daniel Bruun. Árbók* 18: 17–28.
- Bruun, D. & Jónsson, F. 1910. Dalvík-fundet. *Aarbøger for nordisk oldkyndighed og historie*: 62–100.
- Chapman, J.C. 2000. *Fragmentation in archaeology: people, places and broken objects in the prehistory of South Eastern Europe*. London: Routledge. <https://doi.org/10.4324/9780203759431>
- Chapman, J.C. & Gaydarska, B. 2007. *Parts and wholes: fragmentation in prehistoric context*. Oxford: Oxbow books.
- Cochrane, R. 1906. Two Viking brooches and a bowl found in a hillock on a portion of raised beach at Bangor and Groomspoint, County Down. *Proceedings of the Society of Antiquaries of London* 2nd series, 22: 72–79.
- Curle, J. 1914. On recent Scandinavian grave-finds from the Island of Oronsay, and from Reay, Caithness, with notes on the development and chronology of the oval brooch of the Viking time. *Proceedings of the Society of Antiquaries of Scotland* 48: 292–315.
- Dunér, J. & Vinberg, A. 2006. *Barva –2000 år vid Mälarens södra strand*. UV mitt rapport 2006: 20 Arkeologiske förundersökningar och undersökningar. Stockholm: Riksantikvarieämbetet.
- Edwards, B.J.N. 1969. The Claughton Viking burial. *Transactions of the Historical Society of Lancashire & Cheshire* 121: 109–116.
- Eldjárn, K. & Friðriksson, A. 2016. *Kuml og haugfé: úr heiðnum sið á Íslandi*. Adolf Friðriksson [Third edition]. Reykjavík: Mál og menning.
- Ewing, T. 2006. *Viking clothing*. Stroud: Tempus.
- Feveile, C. & Jensen, S. 2006. ASR 9 Posthuset. In: C. Feveile (ed.) *Ribe studier. Det ældste Ribe. Udgravninger på nordsiden af Ribe Å 1984–2000. Bind 1.2*. Aarhus: Jysk Arkæologisk Selskab, 119–191.
- Fuglesang, S.H. 1987. “The personal touch.” On the identification of workshops. In: J.E. Knirk (ed.) *Proceedings of the Tenth Viking Congress, Larkollen, Norway, 1985*. Oslo: Universitetets Oldsaksamlings Skrifter, 219–230.
- Gilchrist, R. 2013. The materiality of medieval heirlooms: from biographical to sacred objects. In H.P. Hahn & H. Weiss (eds) *Mobility, meaning & transformation of things: shifting contexts of material culture through time and space?* Oxford: Oxbow Books, 170–182.
- Gosden, C. & Marshall, Y. 1999. The cultural biography of objects. *World Archaeology* 31(2): 169–178. <https://doi.org/10.1080/00438243.1999.9980439>.
- Hägg, I. 1974. *Kvinmodräkten i Birka. Livplaggens rekonstruktion på grundval av det arkeologiske materialet*. Uppsala: Institutionen för arkeologi.
- Harrison, S.H. 2008. *Furnished insular Scandinavian burial: artefacts & landscape in the early Viking age*. Ph.D thesis, Trinity College, Dublin.
- Hayeur Smith, M. 2004. *Draupnir’s sweat and Mardöll’s tears: an archaeology of jewellery, gender and identity in Viking Age Iceland*. Oxford: Archaeopress.

- Jansson, I. 1981. Economic aspects of fine metalworking in Viking Age Scandinavia. In: D.M. Wilson & M. Caygill (eds) *Economic aspects of the Viking Age*. London: British Museum, 1–19.
- . 1985. *Ovala spämbucklor: En studie av vikingatida standardsmycken med utgångspunkt från Björkö-fyndet*. Uppsala: Uppsala universitet.
- Jones, A.M. 2007. *Memory and material culture*. Cambridge: Cambridge University Press. <https://doi.org/10.1017/CBO9780511619229>.
- Jørgensen, L.B. 1992. *North European textiles until AD 1000*. Aarhus: Aarhus University Press.
- Joy, J. 2009. Reinvigorating object biography: reproducing the drama of object lives. *World Archaeology* 41(4): 540–556. <https://doi.org/10.1080/00438240903345530>
- Kershaw, J.F. 2013. *Viking identities: Scandinavian jewellery in England*. Oxford: Oxford University Press. <https://doi.org/10.1093/acprof:oso/9780199639526.001.0001>
- Klevnäs, A.M. 2016. ‘Imbued with the essence of the owner’: personhood and possessions in the reopening and reworking of Viking Age burials. *European Journal of Archaeology* 19(3): 456–476. <https://doi.org/10.1080/14619571.2016.1190202>
- Kopytoff, I. 1986. The cultural biography of things: commoditization as process. In: E. Appadurai (ed.) *The social life of things: commodities in cultural perspective*. Cambridge: Cambridge University Press, 64–91.
- Lillios, K.T. 1999. Objects of memory: the ethnography and archaeology of heirlooms. *Journal of Archaeological Method and Theory* 6(3): 235–262. <https://doi.org/10.1023/A:1021999319447>.
- Lønborg, B. 1994. Fremstillingen av vikingetidens skålformede fibler. *Kuml* 199–92: 151–164.
- . 1998. *Vikingetidens Metalbearbejdning*. Odense: Odense Bys Museer i kommission hos Odense Universitetsforlag.
- McGuire, E.H. 2010. *Manifestations of identity in burial: evidence from Viking-Age graves in the North Atlantic diaspora*. Ph.D. thesis. University of Glasgow.
- Montelius, O. 1873. Om de ovala spämbucklorna. *Kongl. Vitterhets historie och antikvitets akademis månadsblad* 2: 177–194.
- . 1877. Om de ovala spämbucklorna 2. *Kongl. Vitterhets historie och antikvitets akademis månadsblad* 65–66: 461–484.
- Norstein, F.E. 2020. *Processing death: oval brooches and Viking graves in Britain, Ireland, and Iceland*. Gothenburg: University of Gothenburg.
- Paterson, C. et al. 2014. *Shadows in the sand: excavation of a Viking-age cemetery at Cumwhitton, Cumbria*. Lancaster: Lancaster Imprints.
- Paulsen, P. 1933. *Studien zur Wikinger-Kultur*. Neumünster: Karl Wachholtz Verlag.
- Pedersen, U. 2016. Non-ferrous metalworking in Viking Age Scandinavia: a question of mobility. In: V.E. Turner et al. (eds) *Shetland and the Viking world: papers from the seventeenth Viking Congress*. Lerwick: Shetland Heritage Publications, 263–269.
- Petersen, J. 1928. *Vikingetidens smykker*. Stavanger: Stavanger museums skrifter.
- Rygh, O. 1885. *Norske oldsager: ordnede og forklarede*. Christiania: Alb. Cammermeyer.
- Steffensen, J. 1966. Lýsing mannabeina úr fornminjafundinum í Vatnsdal, Patreksfirði *Árbók* 63: 33–54.
- Þórðarson, M. 1936. Rannsókn nokkurra forndysja, o.fl. *Árbók* 45: 28–46.
- Vigfússon, S. 1881. Brúarfundurinn. *Árbók* 1: 52–56.



# Taylor & Francis

Taylor & Francis Group

<http://taylorandfrancis.com>

## **PART II**

# Fragmentation and archaeological methods



# Taylor & Francis

Taylor & Francis Group

<http://taylorandfrancis.com>

# 7

## THERE IS METHOD IN THE MADNESS – OR HOW TO APPROACH FRAGMENTATION IN ARCHAEOLOGY

*Bisserka Gaydarska*

### Introduction

Archaeology as the study of fragments is a well-known trope. And although most of us are preoccupied with fragments of pots, fragments of tools, fragments of houses or fragments of societies, there has been very little reflection on this epistemological peculiarity of our discipline. Until 2000, there were disjointed yet insightful attempts (e.g. Talalay's (1987) interpretation of broken Neolithic figurine legs) to go beyond the notion that broken objects, monuments or bodies constitute rubbish – an auto-critique stemming from one of the less perceptive legacies of Stuart Piggott (Piggott 1959:14). The seminal work of John Chapman (2000) irreversibly established deliberate fragmentation as a key social practice in Eastern European prehistory, and his ideas have had a much wider resonance in both archaeological theories (e.g. Gamble 2004; Jones 2012) and an ever-increasing number of case studies (see Tables 7.1 and 7.2). Two decades of excellent scholarship have demonstrated the widespread practice of deliberate fragmentation of bodies and things across time and space (Bausch 2010; Brück this volume). Such overwhelming support for breaking as an intentional and meaningful act means that now we can afford to be more selective when discussing fragmentation patterns rather than rehearsing *an nauseam* the perennial arguments for a deliberate practice (Chapman & Gaydarska 2007, 2010). As a long-standing advocate of deliberate fragmentation, I find this newly found freedom to talk about all aspects of fragmentation, rather than being cornered into defending deliberate action, a stimulating relief. And what better expression of this freedom than posing the question – what is a whole? Is a newly shed antler an independent whole, or is it a part of the animal? Is a blade struck from a

core an object in its own right, or is it a part of the stone? Is a still-functioning spoon, albeit with a broken handle a broken object or not? And, last but not least, are there fragments at all if assemblage theory tells us that everything is a part of a wider whole (Bennett 2010)?

Undoubtedly, ‘what is a whole?’ is an important question whose answers, if permitted, will take over the entire volume and, I suspect, with little agreement and overlap. Post-modern and emic/indigenous thinking has been very influential in current Anglophone archaeology in the arguments against boundaries and boundedness and the promotion of permeability and plural ontologies (Olsen 2010; Witmore 2014; Cambridge Archaeological Journal 2021). Thus, a definition of a whole will go against the core notions of fluidity and negotiation of meaning. How would fragments fit, then, in an intellectual discourse where wholes are elusive? I offer the following pragmatic solution that will allow us to talk about fragmentation in a meaningful way, always keeping in mind that wholes are relational phenomena. If an overall, commonly accepted design or form is affected, then we can recognise fragmentation. Thus, there will be no cross-culturally valid concepts of wholeness, while fragments can still be identified as such.

### Aim and scope of this overview

One of the reasons why fragmentation has been less transient than other theoretical premises in archaeology is the dogged pursuit of appropriate methodology. This paper aims only to sketch the multiple ways in which scholars have tried to make sense of fragments. For an in-depth comprehension of the step-by-step methodology, one is advised to delve into each of the case studies mentioned below (Tables 7.1 and 7.2).

It should be said at the outset that the definition of one overarching methodology for fragmentation is not possible, not least because fragmentation occurs among different kinds of materials. Thus, for example, methods developed for clay vessels will not be suitable for bone figurines. The same caution is necessary for intentional breakage. Conventional wisdom suggests that if a metal object is broken into many pieces, this probably shows a deliberate act, but if a pot is broken into many pieces, the breakage may have been accidental. The benefit of the above-mentioned freedom to have a mature intellectual conversation about fragmentation is that deliberate and non-deliberate fragmentation need not be dichotomised. If a fragment is invested with meaning, how important is it whether it was deliberately or accidentally broken? Did it really matter whether *ostraca*<sup>1</sup> derived from deliberately or accidentally broken objects? What mattered was the re-purposing of the fragment, in this case by inscribing messages in a relevant social context.

Deliberate acts give agency to the objects as well as the people involved in certain practices, and there can be little doubt that intentional breakage

was important. In a cultural context where fragments mattered, if an object was accidentally broken, perhaps its immediate discard was not the first response. Repair, reuse, recycling in some form and even use in practices that involve deliberately broken objects should not be dismissed but they should be acknowledged as cultural practices rather than universal responses. Therefore, in cases where proving deliberate action one way or the other is difficult, how the object is treated is what matters – that a fragment would index an object, an event, a memory or a social practice. Such a new understanding is not a methodological fallback when not finding deliberate damage, nor is it a naïve proclamation that all fragments matter. It is to avoid an essentialist link between action (breaking) and post-action treatment (recycling, disposal, ritual deposition) and to account for a multitude of action-practice situations, such as when both deliberately and accidentally broken objects ended up in the same bundle for smelting, or when skillfully executed, deliberate damage may not be traceable at all (Knight 2019).

Before turning to some examples of best practice in fragmentation studies in archaeology, let us reiterate the key fragmentation approach of the *chaîne opératoire*, a method borrowed from lithic studies (Schlanger 1996). The relevance of this approach in fragmentation studies lies in its delineation of a way of **making** objects and its divisions into three chains: reductive, additive and complex (Chapman this volume, Figure 18.2). The reductive *chaîne opératoire* mimics the classic understanding of this technique, where every subsequent break produces at least two new entities and the sequence of events is ‘imprinted’ in each fragment. In fragmentation studies, the reductive *chaîne opératoire* creates a new whole each time and new ideas of ‘wholeness’ emerge through this practice. An obvious example of this are the blue-stones in Stonehenge ‘cut’ from the Preseli hills (Parker Pearson et al. 2021). The additive *chaîne opératoire* refers to (wo)man-made objects and assemblages, e.g., vessels made of two lumps of clay and a handful of temper. The implication in fragmentation studies is that a broken object can be *added* to create a new whole, whether hewn stones in the making of a tomb or reuse of sherds in the art of kintsugi (see below; see also Chittock this volume; Ojala & Sörman this volume). In the complex *chaîne opératoire*, the physical transformation of one type of object into another often leads to raw materials not easily recognised in the final product – e.g. ore to metal dagger. For fragments, as for these complex *chaînes opératoires*, this means reuse, recycling, or up-cycling not simply as raw materials but also as tokens of places, people and things.

All three types of *chaîne opératoire* are underpinned by the creative agency of fragments and their performative ability to convey messages in commonly shared practice, as demonstrated by the case studies below and the contributions to this volume. The choice of methods to make sense of the sometimes daunting quantities of fragments depends on three key factors: materials,

TABLE 7.1 Fragmentation characteristics by material

<i>Material</i>	<i>Frequency of study</i>	<i>Methods used</i>	<i>Examples</i>	<i>Key implications</i>
Pottery (mostly clay vessels but also figurines, lamps, etc.)	Highest	Refitting (including criteria for assessing refits); experiments; fragmentation or completeness indices; abrasion index; surface pottery area analysis; petrographic thin-section analysis;	Schiffer 1983, Schiffer and Skibo 1989, Nielsen 1991, Kadrow 1992, Orton et al. 1993, Bollong 1994, Pyke and Yiouni 1996, Byrd and Owens 1997, Rogius et al. 2001, Kuna and Profantová 2005, Chapman and Gaydarska 2006, Buko 2008, Blanco-González and Chapman 2014b; Blanco-González et al. 2014, Řídký et al. 2014, Vuković 2015, McFadyen 2016, Spatzier 2018, Arnoldussen and de Vries 2019	range of research questions – from counting the number of fragments to estimating the distribution of ceramic types to defining the nature of deposition (e.g. sacred or profane); enchainment of people, places and things
Metal	high	Refitting, experiments, Damage Ranking System, analysis of hoards	Bradley and Ford 2004, Hansen 2016, Knight 2019, 2020, Fontijn 2019	the intersection of various actions on or with an object may result in its accidental breakage, but equally, they may reveal grades of intentionality
Chipped stone	high	Refitting, <i>chaîne opératoire</i>	De Grooth 1990, Skourtopolou 2006, Salisbury and Engelbrecht 2018	identifying industries, techniques and <i>chaîne opératoire</i> ; social implication of broken lithic artefacts; spatial distribution of lithics as evidence of social networking

Ground and polished stone	low	Refitting, experiments, artefact biography	L'Helgouach & Le Roux 1986, Renfrew 2015, Watts 2014, Martínez-Sevilla et al. 2020	Range of skills needed – from axes to quern stones to megaliths; selective deposition of fragments; such variability that each deposit captured the essence of the situation that produced it.
shell	low	Refitting, experiments, artefact biography	Chapman & Gaydarska 2007, Chapter 7	Inter-household enchainned links in settlements, enchainned links between lands of living and dead in cemeteries
Osseous material	low	Analysis of size, laterality, completeness and fragmentation	Valera et al. 2019	'odd deposits' with variability underlined by contrasts in pottery and animal bone deposition

---

the scale of study (and therefore the scale of the practice) and deposition patterns. In this paper, I discuss these factors briefly, together with the three most common methods: experiments, refitting and artefact biography. I conclude with a positive vision of the future avenues of fragmentation studies.

### Which materials?

In Table 7.1, I provide a small selection of fragmentation studies of different types of materials. Pottery dominates, and although the traditional treatment of fragments to synchronise strata or the use of refitting to restore vessels/figurines remains strong in some parts of the world, there is also an increasing number of studies looking to unlock the enormous potential of sherds to answer an array of research questions, from Schifferian site formation to modern provenance studies to the nature of deliberate practices. Since pottery remains the most abundant archaeological material, which is also one of the most fragile, it is currently the leading inspiration for both the development of new methods to study fragments (e.g. digital refitting at Abydos: Garnett, n.d.; cf. Plutniak et al. this volume) and the potential of such studies for social interpretations (Blanco-Gonzalez & Chapman 2014a).

Metal has recently acquired a similar capacity for inspiring new research questions through the experimental and analytical work of Knight (2019, 2020). A complex web of experiments, contextual comparisons and stages in observations has led to the introduction of the Damage Ranking System, which can rate damage (including fragmentation, among others) to metal objects while also assessing the degree of intentionality. Damage and breakage did not render objects useless and destined for recycling or exclusively decommissioned and destined for ritual deposition, revealing a much more complex picture of use, reuse, recycling and deposition.

The different kinds of stone objects create contrasts in fragmentation practice. Silica-based minerals are brittle, and tools and debitage made of chert, flint or obsidian can be re-shaped, re-sharpened and re-fashioned with manual skill. Fragmentation and refitting in lithics studies rely heavily on identifying industries, techniques and the *chaîne opératoire*, but there are notable exceptions with authors looking for the social implication of broken lithic artefacts (e.g. Skourtopolou 2006; Salisbury & Engelbrecht 2018). By contrast, ground stone is very difficult to break with or without intent. While fragmenting large stones incorporated in different megalithic monuments, such as at Gavrinis, La Table des Marchands and Er-Grah (L'Helgouach & Le Roux 1986), may have required skills similar to those of quarrying, breaking smaller objects like querns and grinding stones (Figure 7.1b) may have been within the abilities (see below) of a wider pool of people. Last but not least, experiments in stone bead-making confirm that accidental breakage does occur during production, but in relatively few cases.

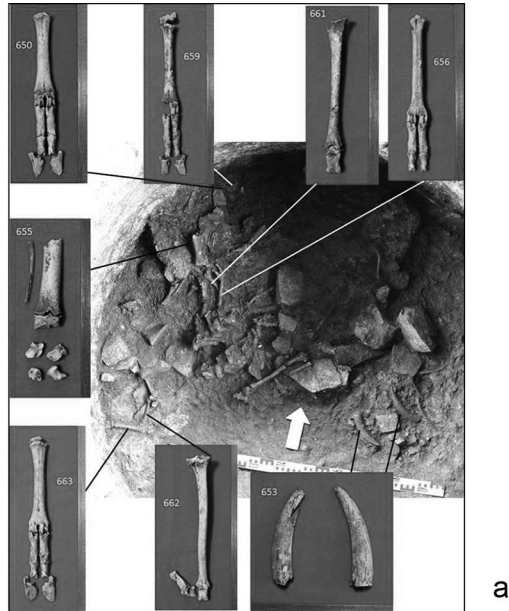

**FIGURE 7.1** Fragmentation studies of different materials: (a) bone (after Valera et al. 2019); (b) ground stone (after Martínez-Sevilla et al. 2020) (photograph by Miguel Ángel Blanco de la Rubia, by courtesy of the research group ATLAS of the University of Sevilla, Spain).

Various species of shell have been found in the archaeological record, but of most current relevance are the ornaments made of the spiny oyster shell, *Spondylus gaederopus*. Lengthy discussions of refitting exercises at two mortuary sites and one settlement have revealed a complex attitude towards fragmented ornaments in conjunction with their wear, polish, colour and shine (Chapman & Gaydarska 2007, Chapter 7). While exquisite, colourful and highly polished complete, but also broken, ornaments were certainly preferred, they were often deposited with single, very worn pieces. Repairs such as those shown above/below (Chapman this volume, Figure 18.3) are rare but demonstrate the juxtaposition of shine and wear.

Dedicated fragmentation studies of various osseous materials – bone (Figure 7.1a), antler and teeth – remain rare, perhaps because animal bones receive different treatment from that of human remains (see Hull this volume). Valera et al.'s (2019) research shows how contrasts in the sidedness of animal bone deposits, the size of the bones and their articulation or lack of it form the basis for performances defining daily lifeways at the Neochalcolithic enclosures of Perdigões in Portugal.

The high potential of metal, lithics and osseous materials for reworking means that these objects are in a state of constant becoming, with their unstable meanings ripe for transformations of form and decoration. It is thus problematic to identify a bronze fragment as part of a production process rather than an enchainment link; it could well hold both meanings.

There are also materials, such as wood and basketry, that do not lend themselves to breaking *per se* but are prone to damage and decay. Such materials remain largely unexplored in terms of fragmentation, but it is worth noting Kückler's (1988) study of the deliberate sharing of *malangan* wooden sculpture fragments on New Ireland to confirm economic transactions. However, repurposed fragments of Bronze Age wooden boats have been found in Bronze Age bridges (van de Noort 2009).

Returning to the search for methodologies for establishing the intentionality of breaking, by far the most convincing approach since the pioneering ideas of J. Chapman in the early 2000s is the experimental work performed on various materials. The Vădastra experiment (Chapman & Priestman, in press) showed some expected but also some unexpected results. Stone and metal rarely broke when dropped, while glass and pottery broke on some surfaces only. Earthen floors and grassy areas were inefficient for fragmentation, while wooden and stone/cobbled surfaces did the job. The lighter the object, the less likely it was to break, while composite objects (e.g. figurines made of two or three lumps of clay) were more likely to snap at weak points. Experimental fragmenterists' attempts to break various materials proved more difficult than anticipated, with additional force and special skills needed for fragmentation of all materials. The morphology of the object – especially its thickness and form of joins – affected the ease or difficulty of intentional

breakage. Some materials, like metal and stone, required heat in advance of potential deliberate fragmentation. Among the many lessons from the metal experiments (Knight 2019) is the role of specialised technological knowledge of how the material works. The absence of tool marks on metal objects does not necessarily mean a lack of intent but may indicate the expert skill needed to break the object on the first strike.

### **Scale of study, patterns of deposition and artefact biography**

In Table 7.2, I aim to give a flavour of the various depositional contexts in which fragmentation practice has been studied. Contexts range from a single pit to an entire landscape. This huge variation in spatial scale has two important implications: first, the size of the social group participating in fragmentation practices; and second, the complexity of the deposition patterns indicating those taphonomic and site formation processes germane to fragmentation. The notion of artefact biography has been instrumental in aiding our understanding of deliberate practices.

Starting with depositional patterns, there is a long-running debate on whether archaeology deals with ‘systemic contexts’, ‘rubbish’ or ‘structured deposition’ (Richards & Thomas 1984; Brück 2006; Garrow 2012). The sometimes antagonistic tone of this discourse has led to two unhelpful dichotomies that influence our interpretations: mundane vs. non-mundane contexts on the one hand and deliberate vs. non-deliberate fragmentation on the other hand. Such dichotomies are problematic as mundane and non-mundane deposition often leads to similar patterning (for the variety of contexts in which Mesoamerican imagery is found, see Guernsey 2020), and fragmentation may or may not be deliberate (see above, p. xx). The devil is in the contextual detail, and no essentialist links should be made. A more valuable way to look at the interrelationship of context and fragmentation is presented in Table 7.3, which questions already established contrastive depositional patterns, such as ritual deposition of metal objects in water and utilitarian deposition of metal objects in the earth.

The examples in the left-hand column are the cases referred to in Table 7.2: the Öcsöd face-pot and the Dolnoslav figurines. The right-hand column refers to the excellent intra-site refitting study of Madison points at the site of Eaton in the USA, where refits made between fragments in different houses were interpreted as a result of food-sharing (Salisbury and Engelbrecht 2018); and the poignant account of children collecting shrapnel fragments after air raids in many UK and German cities during WWII in a subconscious attempt to ‘domesticate’ the ugly reality of war (Moshenska 2008).

Even a short overview of fragmentation studies, such as the one offered in Table 7.2, reveals a huge variety of depositional contexts and practices. Fully excavated sites, like Dolnoslav and Kilverstone, refute the notion of

TABLE 7.2 Fragmentation characteristics by scale of investigation

<i>Type of context/ number of finds</i>	<i>Frequency of study</i>	<i>Method used</i>	<i>Examples</i>	<i>Key implications</i>
<i>Single context - one type of material</i>	high	Refitting	'pottery depot' from a pit in the Neolithic site Parța I, Romania (Germann & Resch 1981)	non-refitting 'orphan' fragments, each representing one of 645 separate vessels, thus integrating the meaning of a 'library' of artefact biographies
<i>Single context – multiple materials</i>	high	Refitting artefact biography	Composite hoard from the Omurtag Tell, Bulgaria (Gaydarska et al. 2004)	Focus on the main question of the fragmentation premise – where are the missing pieces?
<i>Multiple contexts in one part of a site and one type of material</i>	Low to moderate	Refitting artefact biography	Two fragmentary vessels from the Late Neolithic tell of Öcsöd-Kováshalom Hungary (Raczky et al. 2018)	Dispersal of refitting sherds is not random but part of 'the local systemic context' and a result of commemorative deposition involving deliberate fragmentation
<i>One type of material over a whole site</i>	low	Refitting, artefact biography	Clay figurines from Dolnoslav tell, Bulgaria (Chapman & Gaydarska 2007, Chapter 6)	More than 400 figurine fragments have their matching parts deposited off-site in other places; classic example of the enchainment of people, places and things
<i>Multiple types of material over a whole site</i>	lowest	Refitting, artefact biography	Sherds and flint artefacts from pits or clusters of pits in the Neolithic site of Kilverstone, UK (Garrow et al. 2005).	need to rent a warehouse to conduct a refitting exercise on this scale; the importance of artefact biography; the persistence of place, defined through the practice of rituals of (refitting) object deposition in pits to mark seasonal return and departure
<i>Micro-region between sites</i>	lowest	Refitting, pottery neutron activation analysis	marble figurines on the island of Kavos, Greece (Renfrew 2015).	five-stage 'life history', starting with figurine-making at seven different places across the Aegean, followed by a series of manipulations – participation in ritual and ceremonies, starting at the place of origin and finishing with deposition at Keros as part of pilgrimage celebrations.

TABLE 7.3 Fragmentation characteristics by scale of investigation

	<i>Deliberate fragmentation</i>	<i>Non-deliberate fragmentation</i>
• Mundane context	• Pottery	• Iroquois
• Non-mundane context	• Figurines (Dolnoslav)	• WWII shrapnel

accidental breakage and random deposition of fragments, but the majority of archaeological sites have been either partially excavated or their material has been partially studied. In such cases, it is crucial to understand what happened to the fragments post-breakage through an appreciation of deposition, site formation and artefact biography. The assessment of taphonomy/site formation can be complex, as demonstrated in an exemplary study of the Final Bronze Age site of Roztoky, Czech Republic, where the combination of spatial analysis, pottery fragmentation patterns and variations in the derivation of the deposited sherds led to the interpretation of the site as a single homestead occupied over five generations (Kuna 2015). But assessments could also be more reflective, for example, in the search for the meaning of the mortuary deposition of fragmented objects. The intra-site refit between a sherd in grave 584 and a sherd from a house in level VII of the adjacent tell in Durankulak, Bulgaria, was not the result of a formal refitting method but rather Henrieta Todorova's photographic memory and intuition (Chapman & Gaydarska 2007, fig. 5.7). Such links between the land of the living and the land of the dead are much more common and await the initiation of adequate refitting exercises. Scientific rigour has been introduced into pottery refitting studies through the use of thin-sectioning and petrographic analyses of pottery temper to show which pairs of macroscopically similar sherds were actually from the same vessel (Blanco-González et al. 2014).

One of the strongest arguments for the reuse of fragments 'after the break' is the numerous examples of post-breakage manipulations such as burning and decoration over the breaks (e.g. the micro-stratigraphies recorded on *Spondylus* bracelets: Chapman & Gaydarska 2007, Chapter 7). This attention to the life history of the fragments is part of a wider approach dealing with artefact biography or object itinerary. Not only were the breaks worn, 'healed', burned or decorated, but fragments of the same object were often treated differently (Blanco-González et al. 2014). The striking contrast of having 'a different life' in refitting sherds, figurines or ornaments (Figure 7.2b) reinforces the idea that broken objects were not immediately disposed of. It is clear that the deliberate and often careful treatment of fragments at Dolnoslav, Kilverstone and Öcsöd emphasises the importance of fragments 'after the break', an attitude that would also relate to fragments that may not necessarily have derived from deliberate action.

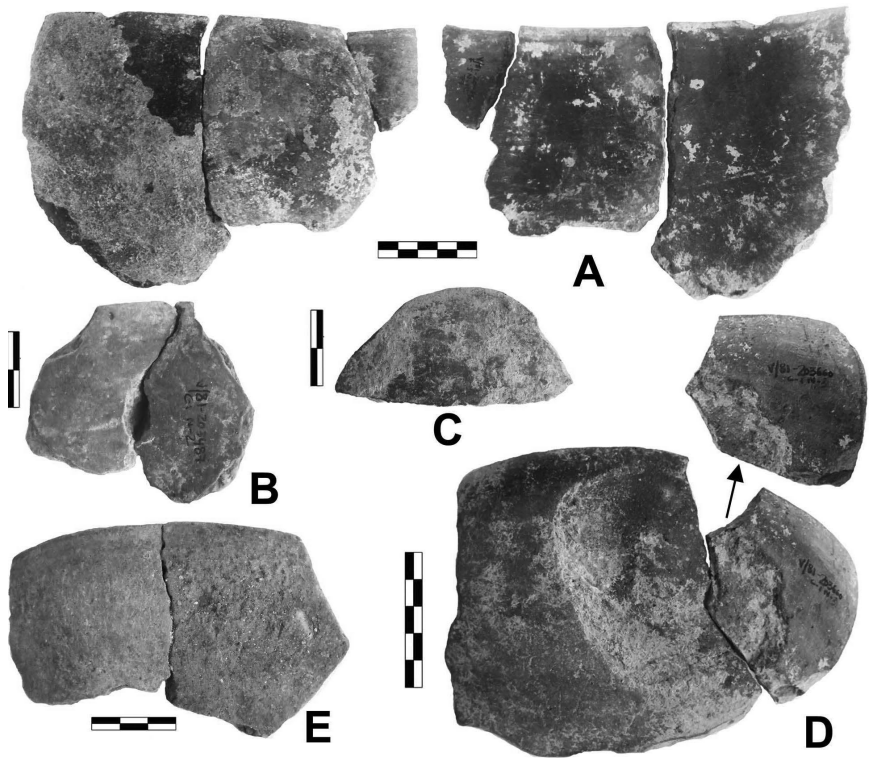

FIGURE 7.2 Sherds refitting: (a) the minimum space needed for appropriate refitting exercise; (b) different ‘life stories’ of conjoining sherds (Blanco-González & Chapman 2014a).

An important caveat is that fragmentation is very often mentioned, and subsequently downplayed, in the context of production debris or recycling. Again, context and object biography are critical here, leading to relevant questions, such as whether an object of ‘production waste’ was immediately

discarded or utilised in a particular way. And although, for the most part, studies of the reuse of fragments distance themselves from the modern concept of ‘economic’ recycling, they are underpinned by the notion of functionality. I would argue that it is equally beneficial to think more along the lines of recycling: incorporating past and present properties of the piece and how they contribute to the ‘new’ property of the emerging object (Caple 2010). Conneller (2011) has shown how the colour and shining quality of previously unused ‘raw materials’ led to their adoption in an innovative suite of Upper Palaeolithic objects.

### **Avoiding and embracing fragments: further avenues**

I have maintained throughout this paper a recognition of the significance of fragments, which has gradually increased over the last two decades. However, the refusal to deal with fragments is very much still with us, whether by prioritising the reconstruction of complete vessels, looking only at diagnostic sherds or aligning with the discredited but still popular notion of fragments as almost always representing rubbish.

We can contrast this with the more creative and imaginative modern ways of engaging with fragments, from the staging of the fragments of the Ancient Greek play “The Trackers of Oxyrhynchus”, together with inserted new sections (Parkyn n.d.) to inter-disciplinary outreach combining fragments in archaeology, history, art and music (Tronzo 2009). Enchainment has been the preferred framework for interpreting fragments in Balkan prehistory, but this is far from the only explanation for breakage. A fascination with fragments, for example, and the way they fuel people’s imagination is demonstrated by complete ancient sculptures representing just heads or feet or more recent beautiful renderings of parts of human bodies, like those of Brancusi (cf. Burström 2013). The Japanese art of *kintsugi* (Figure 7.3b), where broken pottery is mended with powdered gold, integrates two contrasting materials to transform them both into a new artistic synthesis (Keulemans 2016).

### **The current momentum in fragmentation studies reveals four major future avenues for the field**

Engaging the public with fragmented objects should be one of the future goals of archaeology. Conservators (Abend et al. 2010) and museum curators are increasingly open to the idea of exhibiting broken objects as they have a ‘story to tell’ (Garnett n.d.). Fragments of pots, figurines, tools or ornaments are still far from the appreciation enjoyed by fragmented classical sculpture and a fruitful future avenue is extending reception studies to fragmentary people, places and objects. The technology of digital refitting opens up the possibility of refitting museum fragments located anywhere



a



b

**FIGURE 7.3** Reuse of fragments: (a) kintsugi (<https://commons.wikimedia.org/wiki/File:Kintugi.jpg>; Haragayato, CC BY-SA 4.0 <<https://creativecommons.org/licenses/by-sa/4.0/>>, via Wikimedia Commons), (b) ostrakon (Ostrakon with Phoenician inscriptions from Tyre, 3rd century BCE [https://commons.wikimedia.org/wiki/File:TerracottaOstrakon-PhoenicianInscriptions\\_3rdCenturyBCE\\_NationalMuseumOfBeirut\\_RomanDeckert03102019.jpg](https://commons.wikimedia.org/wiki/File:TerracottaOstrakon-PhoenicianInscriptions_3rdCenturyBCE_NationalMuseumOfBeirut_RomanDeckert03102019.jpg); RomanDeckert, CC BY-SA 4.0 <<https://creativecommons.org/licenses/by-sa/4.0/>>, via Wikimedia Commons).

in the world, whether during post-excavation studies on a single site or the integration of field projects with museum collections, as illustrated by the refitting of sherds from different excavation areas at Abydos, Egypt (Garnett n.d.).

First-hand experience of the act of fragmenting can only be achieved at present through experiments or enactment, viz., when most contributors to this volume participated in a workshop where a vessel was broken, and after this ‘fragmentation event’, all present were enchained with the resultant sherds. Contributors to the volume will confirm the immense performative potential of the moment of breaking, involving personal but also shared embodied experiences of sound and sight, and if the process included the pre-treatment of stone or metal with fire or heat, then the sense of smell as well. That performance is re-created in people’s memories every time the resultant fragments are viewed or touched. Thus, an enchained fragment serves as a mnemonic aid referring to people, places and things, but it is also a materialised, embodied experience. We can argue, therefore, that, in enchainment processes, the agency of the fragments consists of their ability to evoke memories of past sensory events while at the same time creating and maintaining social relationships. But such agency is not limited to enchainment. In the case of *ostraca*, for example, the size of the sherd determines the form and length of the message exchange (Figure 7.3a). In the case of classical sculpture, the exhibition of the Venus de Milo in Paris in 1820 ushered in a new value of the fragment in modernity, which at the same time built on and transcended Renaissance attitudes towards the fragment (Vout n.d.). Coming back to methodology, we are at the point where we need to find ways of capturing the performative aspects of fragmentation and the agency of fragments while continuing to offer narratives about the new people, new and continuing identities and new and old relations emerging through fragmentation practices.

The essential issue raised in Section 2 of this chapter, as well as in Table 7.2, is the scale at which fragmentation was carried out. Should we emphasise the household level, the community level, the regional level or all of these levels? On current evidence, summarised in Table 7.2, we can recognise nested fragmentation practices (cf. a Russian doll) whose different implications in terms of scale were underpinned by a common principle, such as cohesion in enchainment practices or the daily outworkings of the habitus in practices of formal and informal disposal, recycling, maintenance activities, etc. Inter-personal enchainment may have involved a figurine or a small object, while communal commemoration may have focussed on a large storage vessel, whereas inter-regional votive ceremonies required a specific category of object, such as marble figurines. The elaboration of the implications of differences in the scale of fragmentation practices offers one possible route for further research.

The question raised in the previous section opens another thus far unaddressed research question: about the number and nature of participants in deliberate practices and consumers of fragments, no matter how produced – about those who break and those who witness. For deliberate practices, based on current evidence, some events may have been intimate and private, others public and still others differentiated through pomp and circumstance, i.e., the significance of context and the milieu of staging the fragmentation. More often than not, breaking would have required skill and specific knowledge and would have been performed by one person or a group of people with similar skills, and if a public event, it would have been witnessed by other people. Whether people witnessing an act of breaking were also recipients of fragments in each and every case is difficult to argue (e.g. the Leslie Grinsell story: Chapman & Gaydarska 2007:1–2), but the ubiquity of such practices suggests people could ‘read’ the sense of fragments. The mourners standing around the Durankulak grave may not have seen the breaking of the vessel with its sherds distributed in the grave and in a house on the tell, but they understood what the deposition meant. Equally, if they would witness the actual fragmentation, they did not take a piece unless very few people were present.

These instances show the complexity of who is doing the breaking (a group or an individual?), who is present, who is taking fragments and who doesn’t but knows what it means. In addition, the reuse of fragments as weights, pendants, grog tempers, etc. – often in less formal settings – does not instantiate the same link between those who break and those who use the fragments. The way that metal objects were broken may suggest the function of the resultant fragments – for utilitarian purposes (recycling) or non-utilitarian ones (deposition). We have made the distinction between figurine-breakers and figurine-makers because of the skills required to achieve certain kinds of breakage. This was also true of metal, chipped stone, ground stone and ground and polished stone. The size of a prehistoric community would influence the number of local people with specialist skills, whether there were many or few. Is it possible that the ‘consumption’ of fragments that required more skill to break may have tended to stimulate a public performance, while those fragments that were easier to break may have been consumed in more private settings? The question arising from this discussion is the significance or otherwise of the division between private and public consumption – another important issue for future research.

## Conclusion

There can be no doubt that things got broken in the past, not necessarily at will, and the resultant fragments were swiftly disposed of. Equally, we now know that there can be no doubt that things, people (and places) were

also deliberately broken for multiple uses of the resultant pieces. What is less clear thus far is the extent to which accidentally broken objects were utilised in practices, such as enchainment, where deliberate fragmentation was essential. We have reached these important insights on the basis of the diligent work of many archaeologists in the last 50 years. This paper has only touched on a few elements of this research to select examples of best practice, where fragments were not frowned upon but taken constructively and studied imaginatively.

Four further conclusions can be drawn not only from the studies mentioned above but also from the many cases that did not find their place here due to space restrictions.

First, and most importantly, fragmented objects and people have increasingly captured the imagination of more professionals, whether field archaeologists, academic archaeologists, museum curators or artists. How fragments are approached depends on the material, as dealing with human bone, for example, is not the same as studying querns or metal ornaments. Approaches are also guided by the research questions asked and the scale of the assemblage under study.

Second, the focus on deliberate fragmentation relies on three key methods – experiments, refitting and object biographies. Experiments have repeatedly shown that accidental breakage is harder to achieve than was widely assumed, while many forms of deliberate fragmentation require skill and specific knowledge. Refitting has transcended its perennial use in the synchronisation of strata and contexts and has demonstrated that its systematic application can betoken both ritual and more mundane practices. Artefact biographies have a much wider application, but this approach has been particularly valuable in fragmentation studies as *becoming a fragment* and the subsequent manipulations with or utilisation of the broken pieces reveal intention and invested meaning.

Third, whichever method or approach is taken, there is always a compromise between resources (time, money, people power, appropriate space – Figure 7.2a, expert knowledge) and the available material. Large-scale refitting programmes are rare, while experiments are often individual pursuits. Looking forward, one way of mitigating such compromises is the inclusion of refitting and, in certain cases, experiments in project research designs, either as part of on-site excavations or as post-excavation studies.

Lastly, due to the restrictions outlined in the previous paragraph, the majority of fragmentation studies have been based on a small sample size. This understandably begs the question – can we make plausible narratives on the basis of a fraction of the data? The answer is a categorical ‘yes’. The fact that the refitting of the Öcsöd face-pot involved no more than 86 fragments does not weaken the overall social conclusions. Moreover, even if no other case of face-pot dispersal is noted (which we know is not the case),

that cannot take away the fact that this one pot was deliberately broken and the subsequent pieces used in a meaningful way. The fragmented pot is an inseparable part of the Öcsöd site biography.

## Note

- 1 An 'ostraca' is a potsherd used as a writing surface.

## References

- Abend, K. et al. 2010. Conserving fragments of icons: clay votive plaques from Hirbermerdon tepe, Turkey. *Studies in Conservation* 55: sup 2: 158–164. <https://doi.org/10.1179/sic.2010.55.Supplement-2.158>
- Arnoldussen, S. & de Vries, K.M. 2019. Appreciating the little sherds in life. On crumbs, sherds and pottery fragmentation. In: S. Arnoldsen et al. (eds) *Metaaltijden 6. Bijdragen in de studie van de metaaltijden*. Leiden: Sidestone Press, 193–216.
- Bausch, I. 2010. Fragmentation practices in central Japan: Middle Jomon clay figurines at Shakado. In: D.Gheorghiu & A. Cyphers. (eds) *Zoomorphic miniature figures in Eurasia, Africa and Meso-America: morphology, materiality, technology, function and context*. Oxford: Archaeopress, 99–112.
- Bennett, J. 2010. *Vibrant matter: a political ecology of things*. London: Duke University Press.
- Blanco-González, A. & Chapman, J. 2014a. Revisiting the Chalcolithic site of El Ventorro (Madrid, Spain). Ceramic re-fitting and taphonomy. *Proceedings of Prehistoric Society* 80: 87–103. <https://doi.org/10.1017/ppr.2014.10>
- . 2014b. A new method for identifying sherd refits: a case study from the Neolithic of Northumbria, U.K. *Journal of Field Archaeology* 39(3): 248–255. <http://dx.doi.org/10.1016/j.jas.2014.06.024>
- Blanco-González, A. et al. 2014. Matching sherds to vessels through ceramic petrography: an Early Neolithic Iberian case study. *Journal of Archaeological Science* 50: 139–152. <http://dx.doi.org/10.1016/j.jas.2014.06.024>
- Bollong, C.A. 1994. Analysis of site stratigraphy and formation processes using patterns of pottery sherd dispersion. *Journal of Field Archaeology* 21(1): 15–28. <https://doi.org/10.2307/530242>
- Bradley, R. & Ford, D. 2004. A long distance connection in the Bronze Age: joining fragments of a Ewart Park sword from two sites in England. In: H. Roche et al. (eds) *From megaliths to metal. Essays in honour of George Eogan*. Oxford: Oxbow Books, 174–177.
- Brück, J. 2006. Fragmentation, personhood and the social construction of technology in Middle and Late Bronze Age Britain. *Cambridge Archaeological Journal* 16(2): 297–315.
- Buko, A. 2008. Pottery fragmentation as a source of archaeological information. *Archaeologia Polona* 46: 149–162.
- Burström, M. 2013. Fragments as something more: archaeological experience and reflection. In: A. González-Ruibal (ed.) *Reclaiming archaeology: beyond the tropes of modernity*. Milton Park, Abingdon: Routledge, 311–322.
- Byrd, J.E. & Owens Jr., D.D. 1997. A method for measuring relative abundance of fragmented archaeological ceramics. *Journal of Field Archaeology* 24(3): 315–320.

- Cambridge Archaeological Journal 2021. Special section: debating Posthumanism in archaeology. *Cambridge Archaeological Journal* 31(3). <https://doi.org/10.1017/S0959774321000135>
- Caple, C. 2010. Ancestor artefacts - ancestor materials. *Oxford Journal of Archaeology* 29(3): 305–318. <http://dx.doi.org/10.1111/j.1468-0092.2010.00350.x>
- Chapman, J. 2000. *Fragmentation in archaeology: people, places and broken objects in the prehistory of South Eastern Europe*. London: Routledge. <https://doi.org/10.4324/9780203759431>
- Chapman, J. & Gaydarska, B. 2007. *Parts and wholes: fragmentation in prehistoric context*. Oxford: Oxbow Books
- . 2010. Fragmenting hominins and the presencing of Early Palaeolithic social worlds. In: R. Dunbar et al. (eds) *Social brain, distributed mind*. Proceedings of the British Academy 158. Oxford: OUP, 413–448.
- Chapman, J. & Priestman, S. in press. The Vădastra experiment. To appear in Gheorghiu, D. (ed.) *The Vădastra Project*. București.
- Conneller, C. 2011. *An Archaeology of Materials. Substantial transformations in early prehistoric Europe*. London: Routledge.
- De Grooth, M.E.T. 1990. Technological and socio-economic aspects of Bandkeramik flint working. In: E. Czesla et al. (eds). *The big puzzle. International symposium on refitting stone artefacts*. Bonn: Holos, 197–210.
- Fontijn, D. 2019. *Economies of destruction: how the systematic destruction of valuables created value in Bronze Age Europe c. 2300–500 BC*. London and New York: Routledge. <https://doi.org/10.4324/9781315109879>
- Gamble, C. 2004. Social archaeology and the unfinished business of the palaeolithic. In J. Cherry et al. (eds). *Explaining social change: studies in honour of Colin Renfrew*. Cambridge: McDonald Institute for Archaeological Research, 17–26.
- Garnett, A. n.d. The Joy of fragments: studying ancient lives at the Petrie Museum (Paper presented to ‘Talking fragments workshop, Durham, 8/IX/2022).
- Garrow, D. et al. 2005. Pit clusters and the temporality of occupation: an earlier Neolithic pit site at Kilverstone, Thetford, Norfolk. *Proceedings of the Prehistoric Society* 71: 139–158.
- Garrow, D. 2012. Odd deposits and average practice. A critical history of the concept of structured deposition. *Archaeological Dialogues* 19(2): 85–115. <https://doi.org/10.1017/S1380203812000141>
- Gaydarska, B. et al. 2004. Breaking, making and trading: the Omurtag Eneolithic *Spondylus* hoard. *Archaeologia Bulgarica* VIII(2): 11–34.
- Germann, C. & Resch, E.F. 1981. Depozitul ceramic de la Parța. *Banatica* 6: 11–33.
- Guernsey, J. 2020. *Human figuration and fragmentation in Preclassic Mesoamerica. From figurines to sculpture*. Cambridge: Cambridge University Press.
- Hansen, S. 2016. A short history of fragments in hoards of the Bronze Age. In: H. Baitinger (ed) *Materielle Kultur und Identität im Spannungsfeld zwischen Mediterraner Welt und Mitteleuropa*. Mainz: Verlag des Römisch-Germanischen Zentralmuseums, 185–208.
- Jones, A.M. 2012. *Prehistoric materialities*. Oxford: Oxford University Press.
- Kadrow, S. 1992. Pottery fragmentation and dynamics of depositional processes inside trapeze-shaped features. *Archaeologica Polona* 30: 69–74.
- Keulemans, G. 2016. The geo-cultural conditions of Kintsugi. *The Journal of Modern Craft* 9(1): 15–34. <https://doi.org/10.1080/17496772.2016.1183946>

- Knight, M.G. 2019. Going to pieces: investigating the deliberate destruction of Late Bronze Age swords and spearheads. *Proceedings of the Prehistoric Society* 85: 251–272.
- . 2020. There's method in the fragments: a damage ranking system for Bronze Age metalwork. *European Journal of Archaeology* 24(1): 48–67. <https://doi.org/10.1017/eea.2020.21>
- Küchler, S. 1988. Malangan: objects, sacrifice and the production of memory. *American Ethnologist* 15(4): 625–637.
- Kuna, M. 2015. Categories of settlement discard. In: K. Kristiansen et al. (eds) *Paradigm found. Archaeological theory present, past and future. Essays in honour of Evžen Neustupný*. Oxford and Philadelphia: Oxbow Books, 278–292.
- Kuna, M. & Profantová, N. 2005. *Počátky raného středověku v Čechách. Archeologický výzkum sídelní aglomerace kultury pražského typu v Roztokách – The onset of the Early Middle Ages in Bohemia. Archaeological research at a large settlement site of the Prague-type Culture at Roztoky*. Prague: Archeologický ústav AV ČR.
- L'Helgouach, J. & Le Roux, C-T. 1986. Morphologie et chronologie des grandes architectures de l'Ouest de la France. In: J.-P. Demoule & J. Guilaine (eds) *Le Néolithique de la France*. Paris: Picard, 181–191.
- Martínez-Sevilla, F. et al. 2020. A new perspective on Copper Age technology, economy and settlement: grinding tools at the Valencina mega-site. *Journal of World Prehistory* 33(4): 513–559. <https://doi.org/10.1007/s10963-020-09150-4>
- McFadyen, L.K. 2016. Actions in time: after the breakage of pottery and before the construction of walls at the site of Castelo Velho de Freixo de Numão. *Estudos do Quaternário* 15: 71–90. <https://doi.org/10.30893/EQ.V0I15.138>
- Moshenska, G. 2008. A hard rain: children's shrapnel collections in the Second World War. *Journal of Material Culture* 13(1): 107–125. <https://doi.org/10.1177/1359183507086221>
- Nielsen, A. E. 1991. Trampling the archaeological record: an experimental study. *American Antiquity* 56(3): 483–503. <https://doi.org/10.2307/280897>
- Olsen, B. 2010. *In defense of things: archaeology and the ontology of objects*. Plymouth: Altamira Press.
- Orton, C. R., et al. 1993. *Pottery in archaeology*. Cambridge Manuals in Archaeology. Cambridge: Cambridge University Press.
- Parker Pearson, M. et al. 2021. The original Stonehenge? A dismantled stone circle in the Preseli hills of west Wales. *Antiquity* 95(379): 85–103. <https://doi.org/10.15184/aqy.2020.239>
- Parkyn, L. n.d. Staging Scraps (Paper presented to 'Talking fragments workshop, Durham, 8/IX/2022).
- Piggott, S. 1959. *Approach to archaeology*. London: A. & C. Black.
- Pyke, G. & Yiouni, P. 1996. *Nea Nikomedeia I: the excavation of an Early Neolithic village in northern Greece 1961–1961. The excavation and the ceramic assemblage*. Athens: British School at Athens.
- Raczky, P. et al. 2018. Domestic and symbolic activities on a tell-like settlement at Ócsöd-Kováshalom in the Tisza Region. In: S. Luca (ed.) *The Image of divinity in the Neolithic and Eneolithic: ways of communication*. Suceava: Muzeul Național al Bucovinei, 117–140.
- Renfrew, C. 2015. Evidence for ritual breakage in the Cycladic Early Bronze Age. The special deposit South at Kavos on Keros. In: K. Harrell & J. Driessen (eds)

- Thrausma: Contextualising the intentional destruction of objects in the Bronze Age Aegean and Cyprus*. Louvain: Presses Universitaires de Louvain, 81–98.
- Richards, C. & Thomas, J. 1984. Ritual activity and structured deposition in Later Neolithic Wessex. In: R. Bradley & J. Gardiner (eds.) *Neolithic Studies: a review of some current research*. Oxford: British Archaeological Reports, 189–218.
- Řídký, J. et al. 2014. How were Neolithic ditches filled in? Deposition study of two enclosures from Bohemia. *European Journal of Archaeology* 17(4): 579–601. <https://doi.org/10.1179/1461957114Y.0000000063>
- Rogius, K. et al. 2001. Buried refuse? Interpreting Early Neolithic pits. *Lund Archaeological Review* 7: 7–17.
- Salisbury, R. & Engelbrecht, W. 2018. Broken points and social cohesion in Iroquoian villages: A point refit study. *Journal of Anthropological Archaeology* 51: 104–112. <http://dx.doi.org/10.1016/j.jaa.2018.06.002>
- Schiffer, M.B. 1983. Toward the identification of formation processes. *American Antiquity* 48(4): 675–706. <https://doi.org/10.2307/279771>
- Schiffer, M.B. & Skibo, J.M. 1989. A provisional theory of ceramic abrasion. *American Anthropologist*. New Series 19(1): 101–115.
- Schlanger, N. 1996. Understanding Levallois: lithic technology and cognitive archaeology. *Cambridge Archaeological Journal* 6(2): 231–254. <https://doi.org/10.1017/S0959774300001724>
- Skourtopoulou, K. 2006. Questioning spatial contexts: the contribution of lithic studies as analytical and interpretative bodies of data. In: D. Papaconstantinou (ed.) *Deconstructing context: a critical approach to archaeological practice*. Oxford: Oxbow Books, 50–78.
- Spatzier, A. 2018. Detecting deliberate fragmentation at a circular enclosure from the late 3rd millennium BC. Calculating fragmentation and refitting analysis of ceramic finds from Pömmelte-Zackmünde, Saxony-Anhalt, Germany. *Præhistorische Zeitschrift* 92(2): 370–386. <http://dx.doi.org/10.1515/pz-2017-0025>
- Talalay, L. 1987. Rethinking the function of clay figurine legs from Neolithic Greece. *American Journal of Archaeology* 91: 161–169. <https://doi.org/10.2307/505214>
- Tronzo, W. (ed.) 2009. *The fragment. An incomplete History*. Los Angeles, CA: Getty Research Institute.
- Valera, A. C. et al. 2019. The fragment, the half and the whole: approaching pottery and fauna depositions in Pit 50 of Perdigões enclosure (first half of the 3rd millennium BC). *Estudos de Quaternário* 20: 11–33. <http://dx.doi.org/10.30893/eq.v0i20.189>
- Van de Noort, R. 2009. Exploring the ritual of travel in prehistoric Europe: the Bronze Age sewn-plank boats in context. In: Clark, P. (ed) *Bronze Age connections: cultural contact in prehistoric Europe*. Oxford: Oxbow Books, 159–175.
- Vout, C. n.d. Broken promises? The case of the crouching Aphrodite (Paper presented to ‘Talking fragments workshop, Durham, 8/IX/2022).
- Vuković, J. 2015. Secondary use, reuse and recycling of ceramic vessels: evidence from Late Neolithic Vinča. *Arhaika* 3: 111–126.
- Watts, S. R. 2014. *The life and death of querns*. Southampton: Highfield Press.
- Witmore, C. 2014. Archaeology and the new materialisms. *Journal of Contemporary Archaeology* 1: 203–246. <https://doi.org/10.1558/jca.v1i2.16661>

# 8

## FOUR PROBLEMS FOR ARCHAEOLOGICAL REFITTING STUDIES. DISCUSSION FROM THE TAÏ SITE AND ITS NEOLITHIC POTTERY MATERIAL (FRANCE)

*Sébastien Plutniak, Joséphine Caro and Claire Manen*

### Introduction

#### *Fragmented objects and uncertain archaeological location*

The location of archaeological remains is of utmost importance for the interpretation of a sequence or the areas of an occupation. What is the location? Formally, it is a relationship between a material entity and a region of space (Cody 2018). In archaeology, objects are usually recorded as being located in spatial “archaeological units” (O’Brien & Lyman 2002), such as stratigraphic units, layers, pits, etc. These units are interpreted in order to define archaeological “contexts” and, finally, to suggest the history of a site. Nevertheless, determining the exact position of an object in a spatial unit is difficult because these units often have vague boundaries (e.g. sedimentary layers, the difference in the internal and external parts of a burial, etc.), and objects might have been moved by anthropic (Chapman & Gaydarska 2006) or non-anthropic (Wood & Johnson 1982; Schiffer 1987) post-depositional actions. Consequently, what we know about the past location(s) of a find is subject to uncertainty. Far from being a neutral observation of “raw data”, spatial units are one of the results of the archaeological process and the outcome of an archaeological investigation. Before any other consideration about contexts or intentional behaviours (Garrow 2012), field archaeologists aim at:

- determining the limits of archaeological units and
- determining the past location(s) of objects (i.e., the – possibly changing – inclusion of objects in archaeological units) to secure their association with archaeological units.

These aims are crucial since they form the basis on which more general statements are built. In this paper, we discuss how studying the refitting fragments of objects contributes to answering these questions.

A common ground in refitting studies in archaeology is to determine whether fragments have been parts of the same original object. Multiple methods were proposed in this regard, e.g., distinguishing between three (Cziesla 1990) or even seven (López-Ortega et al. 2011) types of lithic refits, between six types of pottery refits (Bollong 1994), or calculating the likelihood that non-refitting fragments of similar appearance are from the same object (Blanco-González & Chapman 2014). These methods can be categorised according to whether (1) they are based on similarity relationships (between some properties of the fragments, e.g., decoration, colour, etc.) or connection relationships (physical refit), and (2) they imply counting the number of relationships or the number of sets of fragments linked by these relationships (Table 8.1).

Considering a material object fragmented into multiple pieces, at the time of archaeological observation, the fragments *are* disjointed parts of the original object, but they *were* connected parts of this object in the past. “Refitting” relationships refer to these past *connection* relationships (Plutniak 2021b). They are among the most certain elementary pieces of archaeological knowledge that can be determined because they are either true or false, non-probabilistic, determined by the principles of solid-state physics, and do not rely on external knowledge such as typo-chronologies. Connection relationships provide two aspects of fundamental archaeological information.

- 1 Concerning fragments and objects: connection relationships are strong evidence that two fragments that fit together were part of the same original object.
- 2 Concerning the location of fragments (and the complete original object): the location of a single fragment in an archaeological spatial unit is uncertain due to (anthropic or non-anthropoc) post-depositional processes. However, the more connection relationships there are within a set of fragments from the same spatial unit, the more certain it is that these fragments were primarily deposited in this unit.

**TABLE 8.1** Four types of methods for refitting studies according to the type of relationships processed and what is quantified (sets of fragments or sets of relationships between fragments)

		<i>Count of:</i>	
		<i>Sets of fragments</i>	<i>Relationships</i>
Types of relationship:	Similarity	(1)	(2)
	Connection	(3)	(4)

Note that, in an analysis, connection relationships can be considered as also implying similarity relationships (but the opposite logic is false).

Refitting and fragmentation studies draw on a vast literature. However, this paper addresses four unresolved problems:

- 1 Why methods based on similarities between the properties of fragments are unsatisfactory in this context.
- 2 Why methods based on counting the number of refits can be misleading.
- 3 How the current lack of resources to compare sets of refitted fragments limits our interpretations, and how this limitation can be overcome.
- 4 How an estimation and reconstruction can be made of the original state of an observed fragmented assemblage.

These are general problems that can be addressed based on various types of archaeological remains (lithic, pottery, bones, etc., with possible particularities in each of these cases) and without prior assumptions about the – intentional or non-intentional – causes of fragmentation. These problems are discussed and solutions are proposed, which are then applied to the Neolithic pottery material from the Taï site (Remoulins, France).<sup>1</sup>

#### ***Data: pottery material from the Taï site***

The Taï Neolithic site is located about 40 km from the Mediterranean Sea in one of the valleys deeply carved in a limestone plateau, opening onto the Remoulins plain, at the intersection of several ecosystems favourable to human life. It was excavated during a period from 2001 to 2012 (Manen 2022), enabling the study of the sediment dynamics and its topography, which in turn made it possible to reconstruct the production system of the Neolithic communities and to discuss the functional status of each occupation.

The history of this settlement was investigated through field observations, the study of artefacts, animal and vegetal resources, paleoenvironmental data, and 42 radiocarbon dates. Archaeological excavations have been carried out in three sectors: the “Cave”, the cave’s extension (South “Entrance”), and the Open-air area in front of the cave. These sectors show different degrees of preservation, and the chronological periods of the site are not equally represented. The sediment dynamics are characterised by an alternating succession of anthropic and natural deposits and by erosional phases. In the Cave, the Early Neolithic (EN) deposits are well preserved, protected by the “Entrance”. The “Entrance” area was slowly eroded, and detritic deposits increased in the Cave. From the Middle Neolithic (MN) onwards, human traces are less substantial in the Cave. The unprotected layers in the Open-air sector were eroded. The Late Neolithic occupation was partially preserved due to the significant erosion of the slopes, probably under anthropic

**TABLE 8.2** Number of sherds (NR) and minimal number of individuals (MNI) in the Early Neolithic sub-phases EN1 and EN2 at the Tai site

Layer	Cave		South entrance		Total	
	NR	MNI	NR	MNI	NR	MNI
EN1	540	315	106	73	646	388
EN2	595	362	288	177	883	539
Total	1135	696	394	251	1529	947

pressure, covering and preserving the archaeological layers. In this paper, we draw on the Early and MN pottery material, presented in more detail in a previous study (Caro et al. 2022).

The earliest human occupations belong to the EN and are dated to 5270–4990 cal. BCE. These layers are well preserved in the Cave and in the Entrance (about 40 m<sup>2</sup>) but have been totally eroded in the Open-air sector. However, the dwellings probably extended to the Open-air area, and the Cave could have been used for domestic activities and as a discard area. The EN layers were divided into two subsets (EN1 and EN2) based on stratigraphic arguments and the nature of the sedimentary units (silo and pit filling for EN 1 and circulation layers with hearths for EN2). Pottery material from the Cave and the South Entrance includes 1529 sherds associated with the Epicardial techno-complex (Table 8.2).

After an abandonment period, the site was occupied during the MN, from 4010 to 3700 cal. BCE. The MN layers are poorly preserved in the cave, well-developed in the “Entrance”, and totally eroded in the open-air sector. The lithic industry and the pottery material (N = 2486 sherds, from the South Entrance) are associated with the *Chasséen* techno-complex. Domestic structures are rare, but the deposits present a high density of combustion residues.

Grouping issues have been raised when interpreting this sequence, concerning the EN phase on the one hand and the MN phase on the other. Refitting and fragmentation were used to answer these problems; the rest of this paper discusses and illustrates general methodological issues in fragmentation studies using the EN and MN case studies.

### **Problem 1: Using similarity relationships between fragments generates bias**

During the excavation, six layers were distinguished in the MN phase (based on the sedimentary characteristics and the dispersal of the material), and grouped into two subgroups based on stratigraphic and pottery data: MN1 (Layers 24, 26, and 28) and MN2 (Layers 29, 30, and 31). However, the association of Layer 29 with MN2 is ambiguous; radiocarbon data and

results from the study of lithic materials suggest associating Layer 29 with MN1. This section's aim is to examine whether the distribution of the matching relationships between fragments supports this division or not.

The most common and intuitive approach to archaeological fragmentation in refitting studies has long been to determine and quantify sets of fragments. However, the quantification can concern either the sets of fragments (cases 1 and 3 in Table 8.1) or the relationships between these fragments (case 2 in Table 8.1). In this section, the two approaches are presented and their limits are discussed, paying particular attention to similarity relationships.

### ***Matching sets count and intuitive interpretation***

The study of the 2486 pottery sherds from the MN phase in the South Entrance led to the identification of 37 “similarity” sets<sup>2</sup> (101 sherds; 4% of the total), as well as 71 “connection” sets (251 sherds; 10% of the total). These sets can include fragments from different layers: 77 sherds are included in interlayer “similarity” sets, and 29 sherds are included in interlayer “connection” sets. Of these 108 similarity and connection sets, 84 sets (78%) include only fragments from the same layers; the interpretation of this could be that there was little mixing between layers. However, the remaining 24 sets (22%) with fragments from different layers can be used to test the division between MN1 and MN2. Examining Table 8.3 suggests that the upper part of MN1 (Layers 24, 26, and 28; 16 sherds in total) has fewer interlayer relationships than the bottom part of MN2 (Layers 29, 30, and 31; 88 sherds in total). This supports the distinction between MN1 and MN2 and opposes the association of L29 with MN1.

Nevertheless, several problems are raised by this usual approach: (1) connection and similarity relationships have a similar analytical status, although the first type of relationship is stronger evidence of the fragments being part of a whole<sup>3</sup> than the latter type of relationship. (2) The number of fragments included in each set is not taken into account. (3) There is no clear method, criterion, or threshold to determine whether a spatial unit is well defined, slightly mixed, or too mixed and irrelevant, finally relying on the archaeologists' subjective intuition and experience. Consequently, a more rigorous procedure is needed for the analysis of similarity relationships between fragments, as already stated in a previous attempt to characterise “archaeological similarity networks” (Prignano et al. 2017).

### ***Counting and non-supervised ordering of matching relationships***

In this second approach, the focus is on relationships rather than sets of fragments. Similarity and connection relationships are regarded indiscriminately as matching relationships. Let us consider a matrix with the number and

**TABLE 8.3** Number of sherds according to layers (columns), divided into interlayer sets {similarity sets} and [connection sets] (rows) in the MN phase

<i>Set id</i>	<i>MN1</i>			<i>MN2</i>		
	<i>L24</i>	<i>L26</i>	<i>L28</i>	<i>L29</i>	<i>L30</i>	<i>L31</i>
[10]	2	6				
{27}	1			2		
{51}		1		1		
[66]		2			2	
{26}				1	1	
{38}				1	1	
{41}				1	1	
[63]				1	1	
{48}				2	1	
[68]				2	1	
[71]				2	2	
[41]				3	4	
{49}				1	2	
{49}				1	2	
[54]				1	3	
[56]				1	9	
[62]				3		2
{63}				1		1
[60]				1	5	2
[84]			1			1
[29]		1		1	6	1
[52]	1			4	4	
{70}	1			1	1	1
{25}					1	1
{34}					1	3
Total	5	10	1	30	46	12

proportion of relationships between and within layers (Table 8.4). Reading its diagonal reveals that Layers 26 and 30 have higher proportions of internal relationships, strongly supporting their determination as spatial units.

The number of relationships can be interpreted as a measure of similarity: the more two layers are linked by relationships, the more likely it is that these two layers constitute the same archaeological spatial unit. Theoretically, a spatial unit is expected to be more similar to those near it. In the case of stratigraphic layers, a layer is expected to be more related to the layers directly above and below it. Thus, if we convert the similarity measure into a dissimilarity measure (a distance, in the mathematical sense), hierarchical cluster analysis methods can be applied. We use the Unweighted Pair Group

**TABLE 8.4** Number and proportion of similarity relationships within and between the layers of the Middle Neolithic phase (966 relationships, 72 similarity sets)

	L24	L26	L28	L29	L30	L31	L32
L24	44 (5%)						
L26	28 (3%)	261 (27%)					
L28	0 (0%)	20 (2%)	25 (3%)				
L29	9 (1%)	58 (6%)	7 (1%)	76 (8%)			
L30	5 (1%)	31 (3%)	9 (1%)	82 (8%)	120 (12%)		
L31	1 (0%)	24 (2%)	11 (1%)	26 (3%)	69 (7%)	46 (5%)	
L32	0 (0%)	4 (0%)	0 (0%)	0 (0%)	4 (0%)	4 (0%)	2 (0%)

Method of Aggregation (UPGMA) algorithm, a bottom-up method based on the average of the distances between the objects of the concerned classes at each iteration of the algorithm (Sokal & Michener 1958). Once the dendrogram is obtained, its branches are ordered alphanumerically according to their label (following the stratigraphic order of the layers). Anomalies are revealed when, despite this ordering constraint, the expected order of superposition is not observed in the result.

This method is applied to the six layers of the MN phase. As a result, all the layers are ordered as expected, except L26 and L28, which are inverted<sup>4</sup> (Figure 8.1). Re-examining Table 8.3 helps to explain this anomaly: L26 has more relationships with distant layers (L29, L30, and L31) than with the closer L28. Consequently, the definition of MN1 as a unit including Layers 24, 26, and 28 is not supported. This result qualifies those obtained through intuitive examination of the spatial distribution of the similarity sets. Nevertheless, both methods confirm the association of L29 with MN2, contradicting results from radiocarbon dating and lithic analysis. In summary, the method based on the count of relationships allows for a more accurate estimation of the link between all pairs of layers, confirming the correct ordering of the layers in the sequence while detecting an anomaly (L26, which might be explained by a failure, during the excavation, to detect a cut in L28).

This approach offers (1) an explicit method to analyse matching relationships defined by similarity and (2) a criterion to detect anomalies. Nevertheless, it suffers from the bias specific to similarity relationships: the fact that all the fragments of a matching set are, by definition, linked together, which leads to a multiplication of the number of relations without these being validated by direct observation. This follows a geometrical progression in which  $n$  fragments have  $(n \times (n-1)) / 2$  relations, meaning that 2 fragments have 1 relation, 3 fragments have 3 relations, 4 fragments have 6 relations, 5 fragments have 10 relations, and 10 fragments have 45 relations, etc. A solution

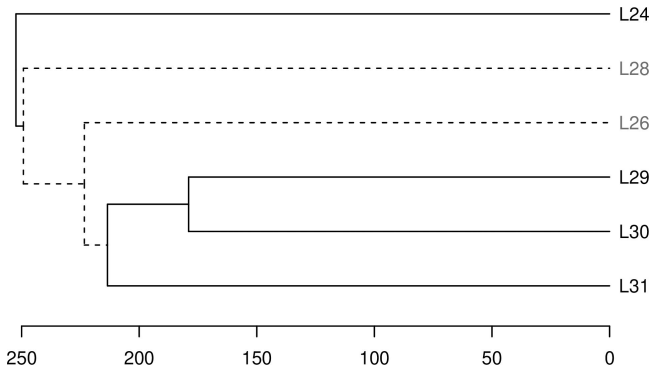

**FIGURE 8.1** Hierarchical classification of the layers of the MN phase. Inverted layers are highlighted by dashed lines and red labels. Data:  $x$ , a matrix with the number of similarity relationships (Table 8.3); distance:  $dist_{ij} = \max(x) - x_{ij}$ ; clustering method: UPGMA.

to overcome this issue is to only use fragments that physically fit together, i.e., connection relationships.

## Problem 2: Counting connection relationships can be misleading

### *Limits of count-based approaches to connection relationships*

Let us now consider using only matching sets defined by connection relationships (case 4 in Table 8.1). This approach is also unsatisfactory, raising two issues that have been discussed in a previous study (Plutniak 2021b). First, suppose we have two archaeological situations with identical numbers of refits between objects and identical proportions of refits within and between spatial units. In such a case, we have demonstrated that different conclusions can be drawn in these two situations about whether the distinction between the two spatial units actually corresponds to two deposition events and about the first location of the objects when deposited. Second, submitting to archaeologists a series of examples where refitting fragments are differently distributed in two spatial units and asking them to evaluate how mixed these units are revealed a low degree of consensus. This demonstrated the need for a formal and explicit method to “weigh” the value of connection relationships in order to differentiate these ambiguous cases.<sup>5</sup> This has been achieved by supplementing the count of connection relationships by considering their relative spatial distribution (their “topology”, i.e., the “structure” of the network of connection relationships between refitted fragments).<sup>6</sup> This was implemented in a method coined TSAR (Topological Study of Archaeological Refitting, Plutniak 2021b), using graph theory to model connection

relationships. This section presents an extension of the TSAR method and applies it to the pottery material from the Tai EN phase.

### *How “strong” is a connection relationship?*

As already mentioned, the more connection relationships there are between a set of fragments from the same spatial unit, the more certain it is that they were originally deposited in this spatial unit. Consequently, non-refitting fragments do not provide information in this regard and should not be considered. In the TSAR method, the weighting procedure aims to evaluate each connection relationship by giving it a number representing the “cohesive” strength of association (between the linked fragments and their spatial unit) provided by this relationship. By default in TSAR, the weighting is computed based on two structural properties of the graphs representing the network of connection relationships: the degree (number of relationships that are incident to a fragment) and the local clustering coefficient of the fragments,<sup>7</sup> as well as a factor based on the relative size of the data sets for each spatial unit (in number of fragments and relationships). This is the basis of the TSAR method.

However, other factors can be considered to determine the “strength” of connections. Let us assume that:

- 1 The size of the objects influences the probability that they might have been moved; small objects are more likely to be transported by natural processes than large ones.
- 2 The distance between connected fragments when they were connected reflected the significance of the (intentional or unintentional) processes that disturbed the object and/or their original spatial units.

These assumptions and their interpretations are summarised in Table 8.5: two connected small fragments found near each other suggest a higher cohesion than two large fragments found far from each other.

**TABLE 8.5** Interpretation of the cohesive “strength” of refitting relationships as a function of the relative size of the connected fragments and the distance between their places of discovery

		<i>Distance</i>	
		<i>Close</i>	<i>Distant</i>
Relative size	Large-Large	+	— — —
	Large-Small	++	— —
	Small-Small	+++	—

The TSAR method has been expanded to include an optional *morphometric factor* (the size of the refitting fragments)<sup>8</sup> and an optional *distance factor* (the distance between the places where they were found) in the weighting procedure.<sup>9</sup> Three variables are combined in order to translate these principles into a factor<sup>10</sup> used to alter the values computed with the topological method only:

- 1 the distance between the findspots of the fragments.
- 2 the size of the fragments (either in terms of length, length by width, area, volume, etc.);
- 3 the relative sizes of the fragments (are they similar or different in size?).

These variables are normalised to the maximum values observed in the studied data set, such as:

$$f(E_{ij}) = 1 - \sqrt{\frac{size_i + size_j}{\max(sizes)}} \times \sqrt{\frac{\frac{size_i}{size_j}}{\max(proportions)} \times \frac{distance_{ij}}{\max(distances)}}$$

with, for each edge  $E(i, j)$  connecting fragments  $i$  and  $j$ :

- $size_i$  and  $size_j$ : the morphometric values for fragments  $i$  and  $j$ ;
- $distance_{ij}$ : the spatial distance between fragments  $i$  and  $j$ .

and

- $sizes$ : the series of sums  $size_i + size_j$ ;
- $proportions$ : the series of ratios  $size_i / size_j$ , with  $size_i < size_j$ ;
- $distances$ : the series of spatial distances between fragments  $i$  and  $j$ .

The morphometric-distance factor is in the range of ]0;1] and is used as a multiplier of the value calculated with the topological weighting procedure. To illustrate this method, it has been applied to the Taï EN pottery material.

### ***Admixture and cohesion of the Early Neolithic layers at the cave Tai***

A graph was built to model the connection relationships within and between the EN1 and EN2 layers for the Cave sector, on the one hand, and for the South entrance, on the other hand (Table 8.6). The number of connection relationships is slightly similar in both sectors, but there are many more fragments and matching sets in the Cave.

When assessing the relevance of the distinction between the layers EN1 and EN2, the TSAR method provides the means to measure the internal

cohesion of each spatial unit and its admixture (based on the fragments and their relationships). These values were calculated using different weighting methods for comparison:

- 1 the topological factor only;
- 2 the topological factor modified by the morphometric factor (multiplying the length of the fragments by their width);
- 3 the topological factor modified by the morphometric-distance factor.

Results are presented in Table 8.7.

### Results

In the Cave, EN1 shows significantly higher cohesion values than EN2, whereas this difference is less significant at the South entrance. The admixture

**TABLE 8.6** Properties of the fragmentation graphs built for the Cave and South entrance sectors (see Plutniak 2021b, Table 2, and the *archefrag* documentation for details)

<i>Parameters</i>	<i>Cave</i>	<i>South entrance</i>
Number of matching sets	31	18
Number of fragments	92	63
Number of relations	78	68
Fragment balance EN1/EN2	0.33	0.28
Object balance EN1/EN2	0.36	0.18
Perturbation	0.08	0.02
Aggregation	0.79	0.85
Planar	yes	yes

**TABLE 8.7** Cohesion and admixture values for EN1 and EN2 by sector and by weighting method (“x, y, z” is a shorthand for the distance factor)

<i>Sector</i>	<i>Method</i>	<i>Cohesion</i>		<i>Admixture</i>
		EN1	EN2	
Cave	topology	0.161	0.806	0.033
Cave	topology + morphometry	0.197	0.775	0.028
Cave	topology + morphometry + (x, y, z)	0.163	0.809	0.028
South entrance	topology	0.346	0.654	0.001
South entrance	topology + morphometry	0.405	0.594	0.001
South entrance	topology + morphometry + (x, y, z)	0.377	0.623	0.001

value is also higher in the Cave than at the South entrance. These results stress the variability that might be observed within a single site due to the different development of its sectors and the variation in the sampling method. Different formation and deposition processes occurred in the two sectors. In the Cave, the EN layers are made up of numerous pits used as dumps, filled with more “disconnected” discards. In the South entrance, EN layers instead correspond to “soil layers”, which are more coherent. Interpreting the cohesion and admixture values (see Plutniak 2021b, Table 8.1), for details about the interpretation method) supports the identification of Layer EN2 and suggests that fragments were moved from this layer (without properly supporting the identification of Layer EN1 to which the fragments might have moved).

#### *Effects of the morphometric-distance factor*

Using this case study, these results allow estimation of the effects of the three weighting methods on the cohesion and admixture values. Compared to the use of the topological factor only, using morphometric data tends to reduce the difference between layers EN1 and EN2 in regard to the degree of cohesion. However, using morphometric data and spatial distances results in values similar to those generated with the topological method only, with a slightly lower admixture value in the Cave sector, whereas in the South Entrance, admixture values stay very low with the three methods.

In summary, this method allows the calculation of the cohesion and admixture of pairs of archaeological spatial units on a scale from 0 to 1. The resulting values contribute to the interpretation of the history of the part of the site under consideration. However, this approach has limits since (1) it applies only to pairs of spatial units and (2) it does not include references to compare and interpret the computed values. In other words, some issues related to the comparison of sets of connected fragments remain unsolved.

### **Problem 3: Reference data to compare sets of refitting fragments are limited**

#### *The limits of archaeological observation*

Whatever the method (counting matching relationships, counting connection relationships only, or the TSAR method), all generate numbers that must be interpreted to determine (1) the archaeological relevance of the definition of a spatial unit as corresponding to a deposition event and (2) the processes (intentional or not) that caused fragmentation and displacement. However, how can these numbers be interpreted? For example, considering two layers, what would be the maximum proportion of interlayer connection relationships before considering that the two layers actually correspond to a single

spatial unit? Would this threshold occur at 2%, 5%, 10%, or even more? How can this threshold be defined other than in a subjective and arbitrary manner? A method might be to determine the extent of changes that occurred in an archaeological sequence. This would involve observing its current state and comparing it with a series of past states. Travelling in time to carry out this series of observations is, unfortunately, impossible. Similarly, reference collections and experimental data sets might also be used to determine thresholds, but these types of data are far too infrequent.

A possible solution, using the TSAR method, is to compare several pairs of spatial units from the same context. It would allow us to state, for example, that layers A and B are less or more mixed than layers B and C. Such an approach was presented above concerning similarity relationships (Figure 8.1) and could also be applied to connection relationships by considering the admixture of fragments as a measure of similarity between spatial units. However, this would only allow comparisons at a *local* scale (e.g. a site); the problem of comparisons at a large scale remains open. In this context, three solutions are considered in this section for future fragmentation studies: (1) the publication of refitting data sets; (2) the generation and publication of experimental fragmentation data; (3) the use of computer-based simulations to generate unobservable situations.

### ***Data publication, experimentation, and simulation as answers***

#### *Publishing data sets*

The first potential means of making data available for comparison is to promote the publication of data sets related to a broad range of archaeological sites, periods, and types of materials (pottery, lithic, fauna, etc.). Open access and non-profit platforms are preferred for this purpose (e.g. *Zenodo*,<sup>11</sup> *Open Science Framework*,<sup>12</sup> *Nakala*).<sup>13</sup> For example, pottery refitting data from the Liang Abu rock shelter (Plutniak 2021a) and the Tai site (Caro & Plutniak 2022) are published in this way. Some data sets are also available on *The Digital Archaeological Record* (tDAR). In addition, tools to make these data sets discoverable on the web should be developed; in particular, indexing concepts in documentation systems. More than thirty years ago, Erwin Cziesla contributed to this aim by publishing a trilingual vocabulary (French, German, and English) including 12 concepts related to refitting studies (Cziesla 1990:36). Some actual documentation systems include similar concepts: the multilingual *PACTOLS* thesaurus for archaeology lists the concept of “refit” related to lithic material,<sup>14</sup> the *RAMEAU* thesaurus of the French National Library lists the concept of “remontage”,<sup>15</sup> and the German *iDAI.world Thesaurus* includes several related concepts, namely “*Refitting-Methoden*”, “*Zusammensetzung*”, and “*Keramikzusammensetzung*”.<sup>16</sup> These concepts

should be complemented, enriched, made multilingual, or created in the documentation systems that do not yet include them.<sup>17</sup>

### *Experimentation*

A second means to assess refitting data from excavations and to compare this with reference data is to create experimental data sets. As already mentioned, discard and deposition experiments enable direct observation of the stages of a site formation process, which cannot be achieved at actual archaeological sites. Previous taphonomic experimental approaches were carried out at the level of site formation processes (Schick 1986) or at the level of an assemblage, e.g., work studying the abrasion (Schiffer & Skibo 1989) or salt erosion (O'Brien 1990) of pottery surfaces or the morphometry of pottery sherds (Rutkoski 2019). Experimental approaches including fragmentation analysis are even rarer, e.g., refits of pottery sherds and bones (Villa & Courtin 1983), with a focus on the weight, number, and arc of rims of pottery sherds (Chase 1985), on pottery (Malloy 2019) or bone (Morin et al. 2021) dispersion. A qualitative study of fragmentation patterns has also been proposed (García Rosselló & Calvo Trias 2019). Integrating fragmentation studies and refitting studies – both in the field and in the laboratory – is still an open challenge. This involves not only site formation processes but also determining if intentional breakage can be detected from the properties of refitting sets of fragments (Evans & Barrera Hernandez 2017). It can be addressed using the TSAR descriptive methods, paying particular attention to the publication of the resulting data sets in order to enable comparisons.

### *Using artificially generated data*

A third way to overcome the lack of empirical reference data is through simulations and artificially generated data sets. In this context, simulation has been used to estimate the size of an original set of objects based on observed fragments (Orton, 1982; Felgate et al. 2013) or to model post-deposition processes (Brantingham et al. 2007; Carver 2015). A simulation-based approach to fragmentation, with particular focus on connection relationships, was developed within the framework of the TSAR method, presented in detail in previous works (Plutniak 2021b, 2022b), and implemented in the *archeofrag* package (Plutniak 2022a). Let us consider the timeline of an archaeological assemblage, where  $t_0$  corresponds to the state of fragments as they appeared during excavation (Figure 8.1). Archaeologists are interested in reconstructing past states of this assemblage. Determining refitting fragments allows for a partial reconstruction of the objects of the assemblage, which represents a past state  $t_{-1}$ . Note that  $t_{-1}$  is a fictional state, i.e., there is no way to control whether the partially reconstructed objects (at  $t_{-1}$ )

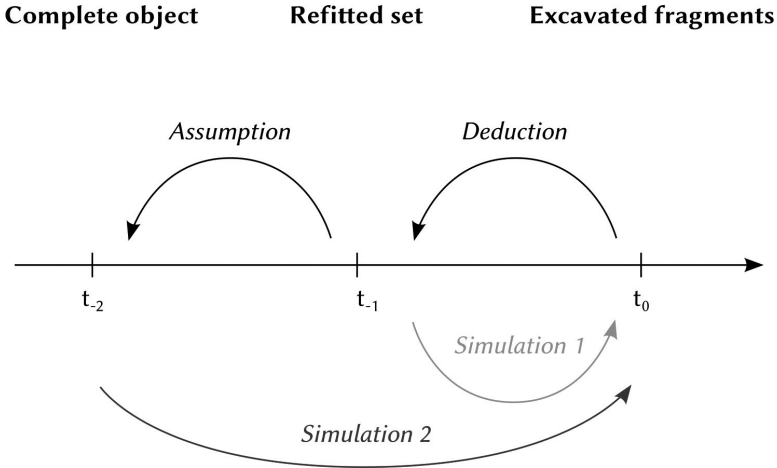

**FIGURE 8.2** Timeline of an archaeological assemblage: type of reasoning applied to determine past scenarios based on empirical observation (top) and uses of simulation (bottom).

have existed contemporaneously (Bordes 1980). Consequently, this state is no more than a reasonable fiction, an approximation of past reality that is useful for archaeological investigation. What the archaeologist observes in the field (at  $t_0$ ) involves pure spatial relationships, the states  $t_0$  and  $t_{-1}$  are like snapshots of a process. What happened during the time between  $t_{-1}$  and  $t_0$  – processes such as movement – cannot be directly observed. This simulator enables simulating different fragmentation scenarios from  $t_{-1}$  to  $t_0$ . This approach has been applied to the Tai MN phase in a previous study, suggesting a scenario where MN1 and MN2 were differentiated within a single original deposition unit (Caro et al. 2022:625–630). Nevertheless, challenges in archaeological fragmentation simulations remain.

**Problem 4: Challenges in simulating archaeological fragmentation**

Reconstructing the state of an assemblage as in  $t_{-1}$  is not sufficient; archaeologists have long been interested in approximating the original composition of complete assemblages, i.e., the number of objects (Orton 1982; Felgate et al. 2013).<sup>18</sup> Consequently, a current challenge is to address what happened in the time gap between the moment corresponding to the partial reconstruction of objects ( $t_{-1}$ ) and, earlier, the “beginning” of the deposition process, i.e., the theoretical initial and original state when all the objects were complete ( $t_{-2}$  in Figure 8.2). Multiple scenarios of fragmentation and movement are possible. Note that, like the  $t_{-1}$  state, the  $t_{-2}$  state is a convenient fiction;

there is no reason to believe that all the considered objects were complete contemporaneously at some point in the past.

Given a fragmentation model (e.g. the model implemented in the TSAR simulator), this is assumed to determine which original states at the time of  $t_{-2}$  best simulate the fragmentation and movement processes that might have led to the  $t_0$  state. This raises a serious problem since assumptions about the initial parameters of the simulation are required (e.g. the initial number of objects and spatial units, the initial distribution of objects in the spatial units, etc.); combinations of possible initial conditions are too numerous to consider. However, recent modelling approaches based on high-performance computing, such as “model exploration” methods, can help. The “Origin Search Exploration” (OSE) method is of particular interest in this context; from the output of a model, it enables the determination of possible combinations of the initial parameters. Conducting an OSE analysis requires, first, a definition of (1) the parameter values for an observed state of a model (e.g., the values describing the state at  $t_0$ ) and (2) the ranges of possible initial values for each parameter of the model. Second, running the OSE procedure led to the determination of which combinations of values best generated the observed state and, consequently, the most probable  $t_{-2}$  states. OSE is implemented on the *Open Mole* platform, which provides convenient access to model exploration methods.<sup>19</sup> Ongoing research is currently being carried out in this direction.

## Conclusion

This paper contributes in two ways to current and future refitting and fragmentation studies. It identifies four problems and has offered – or envisioned – solutions related to: (1) the use of similarity relationships in refitting studies; (2) count-based approaches to refits; (3) the need for reference data to compare fragmented materials; and (4) the simulation of fragmentation processes. Although (1) and (2) are commonly used in archaeology, related, underrated limits and biases have been emphasised, justifying new methodological developments. The use of the topological approach to refitting (the TSAR method) has been illustrated based on the case of pottery material from the Tai site. The importance of combining insights from refitting studies and from other approaches in the interpretation (direct observation of the stratigraphy, geoarchaeology, stylistic analysis, etc.) has been stressed. Problems (3) and (4) are still open and require more investigation, which might lead to further development of fragmentation studies and a better understanding of formation processes at archaeological sites. Here, distinguishing between spatial units in stratigraphic analysis was particularly discussed. However, the four issues addressed cover a wider spectrum of archaeological questions, including distinguishing between forms of intentional and non-intentional breakage. This will be addressed in future studies.

## Notes

- 1 Supplementary data to this chapter are available at <https://doi.org/10.5281/zenodo.7540404>.
- 2 In this analysis “similarity” sets include only sherds with similarity relationships, whereas “connection” sets include at least one connection relationship and the related similar fragments.
- 3 It is what philosophers call a “parthood” relation (Cody 2018).
- 4 Running the same analysis with connection or similarity relationships only leads to similar results.
- 5 Considering similarity relationships, some authors defined scales of certainty in this context (e.g. relations 3 and 4 in (Bollong 1994:18; Blanco-González & Chapman 2014:250–251); however, determining degrees of certainty remains very dependent to subjective evaluation.
- 6 Note that this is not an entirely new idea in this context (Gouletquer 1979:26–29; Cziesla 1990; Michel 2002:122–123), but an idea that has not been developed and applied.
- 7 In graph theory, the local clustering coefficient (or transitivity) is the number of edges between the vertices within its neighbourhood divided by the number of edges that could exist between them.
- 8 Note that morphometric data are used here in relation to transport processes, and not in relation to fragmentation processes.
- 9 This feature has been implemented in the R package *archeofrag* since version 0.7 (Plutniak 2022a).
- 10 See supplementary materials for a study and a calibration of this factor using numerical simulations.
- 11 <https://zenodo.org>.
- 12 <https://osf.io>.
- 13 <https://nakala.fr>.
- 14 The permanent URI of this concept is: <https://ark.frantiq.fr/ark:/26678/pcrtSy10iht5s>.
- 15 <https://catalogue.bnf.fr/ark:/12148/cb159109510>.
- 16 Their URI are [http://thesauri.dainst.org/\\_8d28125c](http://thesauri.dainst.org/_8d28125c), [http://thesauri.dainst.org/\\_3ceb7211](http://thesauri.dainst.org/_3ceb7211), and [http://thesauri.dainst.org/\\_8ba55fff](http://thesauri.dainst.org/_8ba55fff), respectively.
- 17 E.g., *the Library of Congress Subject Headings*, *Wikidata*, *DBpedia*.
- 18 Note that advanced computer-based modelling and simulation were also used for a near –although different– aim, automating the identification of refitting (e.g., Cooper & Qiu 2006).
- 19 <https://openmole.org/OSE.html>.

## References

- Blanco-González, A. & Chapman, J. 2014. A new method for identifying sherd refits: a case study from the neolithic of Northumbria, U.K. *Journal of Field Archaeology* 39(3): 248–255. <http://dx.doi.org/10.1179/0093469014Z.00000000083>
- Bollong, C.A. 1994. Analysis of site stratigraphy and formation processes using patterns of pottery sherd dispersion. *Journal of Field Archaeology* 21(1): 15–28. <https://doi.org/10.1179/009346994791549254>
- Bordes, F. 1980. Question de contemporanéité: l’illusion des remontages. *Bulletin de la Société préhistorique française* 77(5): 132–133.
- Brantingham, P.J. et al. 2007. Modeling post-depositional mixing of archaeological deposits. *Journal of Anthropological Archaeology* 26(4): 517–540. <https://doi.org/doi:10.1016/j.jaa.2007.08.003>

- Caro, J. et al. 2022. Les productions céramiques du Néolithique ancien et moyen: approches céramo-stratigraphique, technologique et morpho-stylistique. In: C. Manen (ed.) *Le Taï (Remoulins – Gard): Les premières sociétés agropastorales du Languedoc méditerranéen. Le Taï (Remoulins – Gard)*. Toulouse: Archives d'Écologie Préhistorique, 616–687.
- Caro, J. & Plutniak, S. 2022. *Refitting neolithic pottery fragments from the Taï site, France*. <https://doi.org/10.5281/zenodo.4719578>
- Carver, G. 2015. Modelling the effects of post-depositional transformations of artifact assemblages using Markov chains. In: J.A. Barceló & I. Bogdanovic (eds) *Mathematics and archaeology*. Boca Raton: CRC Press, 293–313.
- Chapman, J.C. & Gaydarska, B.I. 2006. *Parts and wholes: fragmentation in prehistoric context*. Oxford: Oxbow Books.
- Chase, P.G. 1985. Whole vessels and sherds: an experimental investigation of their quantitative relationships. *Journal of Field Archaeology* 12(2): 213–218. <https://doi.org/10.1179/jfa.1985.12.2.213>
- Cody, G. 2018. Location and mereology. In: E. N. Zalta (ed.) *The Stanford encyclopedia of philosophy*. Available from: <https://plato.stanford.edu/archives/fall2018/entries/location-mereology/>
- Cooper, J.R. & Qiu, F. 2006. Expediting and standardizing stone artifact refitting using a computerized suitability model. *Journal of Archaeological Science* 33(7): 987–998. <https://doi.org/10.1016/j.jas.2005.11.005>
- Cziesla, E. 1990. On refitting of stone artefacts: international symposium on refitting stone artefacts. In: E. Cziesla et al. (eds) *The big puzzle*. Bonn: Holos, 9–44.
- Evans, S. & Barrera Hernandez, S. 2017. Sherd shatter patterns experiment. *EXARC Journal* 3. Available from: <https://exarc.net/ark:/88735/10301>
- Felgate, M.W. et al. 2013. Estimating parent population of pottery vessels from a sample of fragments: a case study from inter-tidal surface collections, Roviana lagoon, Solomon Islands. *Journal of Archaeological Science* 40(2): 1319–1328. <http://dx.doi.org/10.1016/j.jas.2012.09.009>
- García Rosselló, J. & Calvo Trias, M. 2019. Etnoarqueología como experimentación: propuesta para la interpretación de los patrones de fractura. *Treballs d'Arqueologia* 23: 181–202. <https://doi.org/10.5565/rev/tda.108>
- Garrow, D. 2012. Odd deposits and average practice. A critical history of the concept of structured deposition. *Archaeological Dialogues* 19(2): 85–115. <https://doi.org/10.1017/S1380203812000141>
- Gouletquer, P. 1979. *Préhistoire du futur: Connaître les pays est un repos*. Morlaix: Éditions Bretagne.
- López-Ortega, E. et al. 2011. Lithic refitting and movement connections: the NW area of level TD10-1 at the Gran Dolina site (Sierra de Atapuerca, Burgos, Spain). *Journal of Archaeological Science* 38(11): 3112–3121. <http://dx.doi.org/10.1016/j.jas.2011.07.011>
- Malloy, H. 2019. *Experimental archaeology and formation processes: New experiments with spatial modeling*. Senior Thesis. UVM College of Arts; Sciences College. Available from: <https://scholarworks.uvm.edu/castheses/55/>
- Manen, C. (ed.) 2022. *Le Taï (Remoulins – Gard): Premières sociétés agropastorales du Languedoc méditerranéen (6<sup>e</sup>–3<sup>e</sup> millénaire avant notre ère)*. Toulouse: Archives d'Écologie Préhistorique.
- Michel, R. 2002. *Saint-Blaise/Bains des Dames, 3. Typologie et chronologie de la céramique néolithique: Céramostratigraphie d'un habitat lacustre*. Neuchâtel: Service et musée cantonal d'archéologie.

- Morin, E. et al. 2021. A refitting experiment on long bone identification. *International Journal of Osteoarchaeology* 31(4): 650–662. <https://doi.org/10.1002/oa.2980>
- O'Brien, M.J. & Lyman, R.L. 2002. The epistemological nature of archaeological units. *Anthropological Theory* 2(1): 37–56. <https://doi.org/10.1177/1463499602002001287>
- O'Brien, P. 1990. An experimental study of the effects of salt erosion on pottery. *Journal of Archaeological Science* 17(4): 393–401. [https://doi.org/10.1016/0305-4403\(90\)90004-O](https://doi.org/10.1016/0305-4403(90)90004-O)
- Orton, C.R. 1982. Computer simulation experiments to assess the performance of measures of quantity of pottery. *World Archaeology* 14: 1–20.
- Plutniak, S. 2021a. *Refitting pottery fragments from the Liang Abu rockshelter, Borneo*. Zenodo. <https://doi.org/10.1016/j.quaint.2015.11.080>
- . 2021b. The strength of parthood ties. Modelling spatial units and fragmented objects with the TSAR method – Topological Study of Archaeological Refitting. *Journal of Archaeological Science* 136: 105501. <https://doi.org/10.1016/j.jas.2021.105501>
- . 2022a. R package version 0.8.2. *Archeofrag: an R package for refitting and spatial analysis in archaeology*. <https://doi.org/10.21105/joss.04335>
- . 2022b. Archeofrag: An R package for refitting and spatial analysis in archaeology. *Journal of Open Source Software* 7(75): 4335. <https://doi.org/10.21105/joss.04335>
- Prignano, L. et al. 2017. Wiring the past: a network science perspective on the challenge of archaeological similarity networks. *Frontiers in Digital Humanities* 4. <https://doi.org/10.3389/fdigh.2017.00013>
- Rutkoski, A.M. 2019. *An experimental approach to sherd variation*. Master of Arts Thesis. Kent State University, College of Arts; Sciences, Department of Anthropology. Available from: [http://rave.ohiolink.edu/etdc/view?acc\\_num=kent1555764606649139](http://rave.ohiolink.edu/etdc/view?acc_num=kent1555764606649139)
- Schick, K.D. 1986. *Stone age sites in the making: experiments in the formation and transformation of archaeological occurrences*. Oxford: Archaeopress.
- Schiffer, M.B. 1987. *Formation processes of the archaeological record*. Albuquerque: University of New Mexico Press.
- Schiffer, M.B. & Skibo, J.M. 1989. A provisional theory of ceramic abrasion. *American Anthropologist* 91(1):101–115. <https://doi.org/10.1525/AA.1989.91.1.02A00060>
- Sokal, R.R. & Michener, C.D. 1958. A statistical method for evaluating systematic relationships. *University of Kansas Science Bulletin* 38: 1409–1438.
- Villa, P. & Courtin, J. 1983. The interpretation of stratified sites: a view from underground. *Journal of Archaeological Science* 10(3): 267–281. [http://dx.doi.org/10.1016/0305-4403\(83\)90011-0](http://dx.doi.org/10.1016/0305-4403(83)90011-0)
- Wood, W.R. & Johnson, D.L. 1982. A survey of disturbance processes in archaeological site formation. In: M.B. Schiffer (ed.) *Advances in archaeological method and theory: selections for students from volumes 1–4*. New York: Academic Press, 539–605. <https://doi.org/10.1016/B978-0-12-624180-8.50016-0>

# 9

## DESCRIBING IDENTITY

### The individual and the collective in zooarchaeology

*Emily H. Hull*

#### Introduction

In ‘Auguries of Innocence,’ William Blake wrote: “To see the world in a grain of sand / or heaven in a wildflower. Hold infinity in the palm of your hand / and Eternity in an Hour (Blake et al. 1968: 1789–1794).” Like Blake, in archaeology we are often left with only grains of sand, trying to extrapolate forgotten, fragmented, or remote times and places. Archaeology is ultimately the pursuit of reconstruction, of reassembling the fragments of the past, and we do this in ways both literal and theoretical. We attempt to reconstruct the tattered remains of civilisation, environments, faiths, and communal and individual lives, often from shattered ruins and broken bones. In zooarchaeology, we face the added task of working with individuals whose place in society has shifted dramatically throughout times and cultures, whose social roles can be various and shifting, and whose lives, emotions, and experiences are further from our understanding than those of humans of the distant past. These voiceless non-human persons are often fragments of fragments (in the form of pieces and particles of bone), displaced pieces of a puzzle that remain understudied, underrepresented, and underrespected, even as their existence has built, clothed, fed, comforted, and sometimes even destroyed the communities that they share with humans.

In human bioarchaeology, mixed and comingled skeletal remains are an important aspect of study, but the focus is often directed towards interments or other burials with distinct, individually discernible sets of remains. A zooarchaeologist’s focus is on the presence and conditions of non-human animals (hereafter animals, as per human-animal studies standards) who have impacted human lives as food, labor, companionship, or entertainment

(Reitz & Wing 1999; Zeder 2006; Watts 2014; Steele 2015). While some animals are granted social personhood, particularly companion animals or pets, most animals with whom humans interact are used for their physical bodies, as labor or for secondary products, and in death as food and secondary resources. Because the procurement of meat and hides entails butchery, the disarticulation and purposeful fragmentation of bone are common, and most zooarchaeological remains are mixed and comingled deposits of skeletons that are not only disarticulated but also in pieces. As Human-Animal Studies push us into asking new questions, we are also faced with a new conundrum: how can we find the individual within these puzzles of broken and comingled remains, and the corollary: when we have only an ‘exceptional’ individual, what can we say about these communities as a whole?

## Background

Fragmentation theory, especially in its theoretical frameworks of wholes, parts, and sets and in its considerations of enchainment and accumulation, can be incredibly beneficial for zooarchaeologists as well as for archaeologists in general (Chapman 2000; Chapman & Gaydarska 2006). As most zooarchaeological subjects have been in some way dismembered, dismantled, or broken, fragmentation theory, when combined with human-animal theory, allows us an expanded vocabulary and framework for discussion of the difficulties in respecting both individual animals and animal communities in zooarchaeology.

Our primary frameworks include the calculation of number of individual specimens present, minimum number of elements, and minimum number of individuals present, and we work stepwise up from parts to wholes to sets (Binford 1962, 1978). All fragmented objects and artifacts present a challenge, but the bodies of non-human persons are particularly suited to this theoretical foundation in assessment. The lives of animals in the zooarchaeological record are defined by both their enchainment to humans (Chapman 2000), their roles in their own communities, and the circumstances surrounding the fragmentation and accumulation of their remains. A domestic animal lives a life of entanglement with humans; control of their lives and their genetic potential is often what leads them to be considered domestic (Zeder 2006). Likewise, food animals, whether domestic or prey, are enchainment in the most fundamental way with the humans who eat them, as their flesh becomes part of the bodies of humans, their skin a second skin, and their bones and teeth and antlers and horns are transformed into tools and ornaments (Chapman 2000). Most zooarchaeological materials are found in sites of accumulation, whether as a midden or dump site used for a long period or the comingled remains of a mass kill. Accumulation becomes another basis for analysis, and individuals represented within the site become members of the new community of “the assemblage.”

A zooarchaeological specimen is not only an object but also part of an individual who once lived and breathed. A single broken femur can give us bountiful information about species, diet, and human hunting and butchering practices, but we never see the whole of the living animal. Further complicating matters, the animal who once lived may have been viewed by humans as an object, a resource, a citizen, a companion, an economic marker, or some combination of these roles (e.g. Hill 2013; Nyysönen & Salmi 2013).

Beyond a human resource perspective, animals hold places within their own animal community, holding roles and responsibilities that were not defined by humans. As a piece of a member of a community, a tiny fragment of bone at the same time represents not only part of an individual but also becomes representative of an entire community.

This paper aims to recontextualise and use fragmentation theory as an accessory to human-animal studies and zooarchaeology. Instead of human interactions with material objects, I aim to show how animals and animal systems can be explored in a system of wholes and parts. These wholes and parts expand beyond the singular animal and explore the interconnectedness of animal social groups, animal bodies themselves, and pieces of animal bodies. The animals whom we study are all enchained to humans: as workers, in the case of sled dogs; as food, in the case of buffalo; and as social groups that contain both, as in the case of reindeer. Using these three examples, I aim to show the benefits and disadvantages of studies on each type of animal remains: domestic, wild, and mixed.

## Zooarchaeology

In the history of archaeology, most animal remains have been studied using quantitative means. With exceptions, archaeologists have historically been interested in animals primarily as objects of economy and utility (Binford 1962, 1978; Boyd 2017). Some of the most fundamental advances in zooarchaeology were made during the development and expansion of processual archaeology. Processual frameworks regarding animals are the basic tools of zooarchaeological assessment today. This is primarily focused on the economic, caloric, and secondary resource value of animals and has been challenged and critiqued by many post-modern theorists and human-animal scholars; nonetheless, it remains an important tool for establishing the parameters of an assemblage.

When other methodologies, including the evaluation of single-bone pathologies, tooth wear patterns, or butchery techniques, are included, these assessments can become more in-depth. In a mixed assemblage, we are still restricted to estimations of group dynamics. For example, if older adults with heavy activity markers and activity-based pathologies are present, a picture emerges of working animals who are butchered once they outlive

their usefulness as laboring agents; likewise, if an assemblage contains mostly young male animals, the economics of breeding and the secondary product usefulness of adult females are established. Despite these valuable data points, the question of an individual animal's life history remains obscure. It is important to note that a single bone that does not fit the patterns can be interesting but cannot be used to make assumptions about a whole animal, much less as a representative of the larger group, and is therefore demoted to an outlier.

As Human-Animal Studies have emerged, there has been an increasing interest in examining animals as living agents rather than simply as objects of utility (Aaltola 2008; MacKinnon 2010; Stammer & Takakura 2010; Boyd 2017). While companion animals have long been interesting to scientists, we are increasingly interested in and focused on animals, which we historically have perceived to have more economic value than social value. This interest in animal lives and their impact on humans beyond being 'meat with feet' has increased with the focus on multispecies analyses and recognition of the roles that animals may play within a holistic society (Puputti 2008).

We are divided from non-human persons not only by species and language but also by theory of mind, the fundamental ways in which we experience the world. Despite these challenges, certain assessments can certainly be made as to quality of life by looking at frameworks of wellness, such as the rubric set out by McMillan (2008), which is based on the factors of social relationships, mental stimulation, health, stress, and personal agency or control. In summary, we have contrasting modes of analysis with two very different fundamental goals: qualitative analysis is primarily individualistic, while quantitative analysis is population-based. These fundamental biases can lead to the exclusive use of qualitative analysis for inquiries into animal life history, while quantitative analysis may be more apt to focus on the human use of animals.

The question of 'who or what does a single bone, especially when that bone is a fragment of a bone, actually represent?' is at the core of a central disconnect within zooarchaeology. We need each artifact, each specimen, and each sliver of bone to be at once less than an individual and representative of an entire community. We address this dichotomy in a variety of ways, but we rarely sit down with the question at the heart of the matter and consider it critically. Analytically, we approach mixed and comingled assemblages in a variety of ways, which generally sublimate the individual's ability to understand the group. We look at percentages of limbs or bones that are present, and, when looking at pathologies, lesions, or activity-related markers, we must find statistically significant numbers to say that there were enough individuals with these characteristics within the group to make substantive claims. These analyses, however, do not address the fact that there will always be one or two individuals who do not fit into the typical group behavior or life histories.

### Animal remains and studies in context

Unlike in human burials (although there are multiple modes and methods of human burial practices), individual animal interment is rare. Some sacrificed animals or animals who have achieved “exceptional” status (e.g., war horses or “hero” dogs) may be given individual burials. With animals utilised for their bodies, this practice is less common, as the use of the body often necessitates dismemberment, butchery, and fragmentation, and these remains are often dumped or buried communally.

In some cases, we may come across an intact burial, intentional preservation, or mummification of an animal. In these circumstances, we can employ methodologies from human osteology in the analysis of these remains, including activity reconstruction and life history via paleopathology and enthesal change and tracing mobility and diet, but some questions remain that require more speculation to answer (Boyd 2007; Dawkins 2008; Henderson 2008; Salmi et al. 2020, 2021). Quality of life and welfare are difficult concepts to determine in animals with whom we cannot only converse but who also have very different sensitivities and physical experiences. This, however, removes the animal from their community and context, therefore showing only part of a social unit.

### Hero dogs

Animal individualism can be seen in one scenario: intact burials or remains of canids, especially domestic dogs (Gräslund 2004; MacKinnon 2010; Losey et al. 2014, 2018; Tourigny et al. 2016; Latham & Losey 2019). In the case of dogs, we sometimes examine the bodies of “exceptional” animals that have been preserved. Both Balto and Togo, the leads of two sled dog teams that made the 1925 Great Serum Run,<sup>1</sup> are recognised as “hero” dogs. Balto, as the lead dog on the final stretch, has been immortalised in popular imagination, including in a 1995 children’s cartoon (Thomas & Thomas 2015; Aboul-Enein et al. 2019). There is still active debate as to whether Balto deserves these accolades, as it was Togo who completed the longest and most perilous stretches of the journey (420 km to Balto’s 89 km) (Salisbury & Salisbury 2003; Kean 2009; Poliquin 2011). Balto and Togo’s bodies were both preserved after death; Balto’s taxidermised remains are on display at the Cleveland Museum of Natural History, and Togo, disarticulated in death, has his hide mounted for display at the Iditarod Trail Headquarters Museum, while his skeleton lies in the collections of the Peabody Museum of Natural History (Salisbury & Salisbury 2003; Kean 2009; Poliquin 2011). Both Balto and Togo are still celebrated and remembered much more than their mushers, Leonhard Seppala and Gunnar Kaasen. However, we see Balto and Togo only in their relationships with humans, and while their daring exploits are romanticised,

we know little about the other members of their sled teams. Working dogs often live very disparate lives from those of companion or pet dogs. On some sled teams, it was historically standard practice to physically harm, underfeed, and mistreat dogs, even pulling out the molars of dogs so that they could not chew through their harnesses. Even in the modern age, with legal enforcement of animal welfare, sled dogs often still live harsh lives (Bellars & Godsall 1969; Dennis et al. 2008; Losey et al. 2014; Latham & Losey 2019).

This is not to say that these were the experiences of Balto and Togo or that this was the *modus operandi* of Seppala, who bred and trained both dogs. However, the serum run was brutal and punishing for all the mushers and dogs, many of whom are unknown to history. Of the over 150 dogs involved in the journey, many died or were severely injured. The cold, exhaustion, and distress faced by all the dogs involved in the run cannot be underestimated (Salisbury & Salisbury 2003; Poliquin 2011).

Sled dogs throughout history have often lived painful lives. The damage done to sled dog bodies from other areas in the Arctic North from the 1880s to 1960s includes skull and tooth lesions from direct human abuse and ankylosing spondylitis from the burdens of their work, and the damage to their bodies, both purposeful and incidental, shows the harsh conditions that these animals have historically faced (Losey et al. 2014; Latham & Losey 2019). Unlike many sled dogs, Togo lived a full and happy life afterwards, due to his status as a hero as well as Seppala's deep affection for him (Salisbury & Salisbury 2003; Thomas & Thomas 2015). Balto had more struggles; he and his team were sold to a sideshow, where they suffered malnutrition and abuse until being bought in 1927 by a group in Cleveland who found their treatment upsetting. Balto finished his life in the Cleveland Zoo, where he was well-fed and cared for but remained a curiosity, much as his mounted skin still is today (Poliquin 2011). Additionally, by singling out the lead dogs, the "heroes" of the run, we divide them from the greater context of their communities. Balto and Togo hold exceptional status, but by dividing them from the other dogs who made the race, we have no way of knowing the life histories of the sled dogs in general and what the differences in their experiences were. This sled dog community is, in this way, fragmented. In death, Balto and Togo have been memorialised not only with statues, books, and films but also with the preservation of their bodies as taxidermised mounts. As much as we might consider them heroes, we preserved their remains as curiosities and souvenirs, not as people. Seppala is certainly not stuffed and displayed in a glass case next to his beloved Togo.

### Mass kills

Head-Smashed-In Buffalo Jump is one of the most impressive and oldest buffalo jumps in North America, where herds of bison were driven off a cliff

by indigenous hunters, maximizing the amount of meat and raw materials that a single hunt could produce (Brink 2008). Because Head-Smashed-In was used for over 6,000 years, the deposits at the base of the jump represent innumerable herds (Brink & Dawe 1989; Brink 2008). These kills represented an important part of the indigenous economy, and the technologies present in the assemblage allow us insight into the human past. The human importance of sites like Head-Smashed-In cannot be underestimated; as a UNESCO world heritage site, a revisitation of site excavations has allowed the reclamation of indigenous knowledge and history (Opp 2013).

From a zooarchaeological perspective, the kills of an entire herd community, such as those at Head-Smashed-In Buffalo Jump, allow analysis of seasonal group population dynamics, herd composition, and general health, but these sites are often so comingled that they are equivalent to human mass graves. Unlike with human remains, it is often not seen as worthwhile to engage in pair-matching bones or DNA analysis to try and identify discrete individuals; although these techniques could potentially be employed, it is often not worth the time and expense to reconstruct a single buffalo from a kill site of thousands or more. The information about herd formation and butchery technologies that can be gleaned from such sites is incredibly valuable, but it does leave out certain aspects of the animal experience. While we may know the general categories of sex and age that were present in a herd, mass kill sites do not give us information on the intricacies of animal lives. We do not know which roles each member of a herd played, or, indeed, if two herds were combined, or if smaller social groups existed within the larger group. From the pieces of smashed and dismembered bodies, we can see how humans procured meat and resources from the site, how they were utilised, and which animals and which parts of animals were preferred. The scientific data for an individual animal, in this case, only exists for their assessment as a number within a category and the rank of that category within the group. The level of deposition becomes the focus, the ‘whole,’ and individual animals are less important than the gestalt. Unlike Balto and Togo, we therefore see the collective but not the individual.

### **Comingled assemblages: domestic and wild entangled**

The sites of Nukkumajoki and Juikenttä are located in Northern Finland and were both sites of forest Sámi habitation within the historical era. Two questions regarding these sites and others like them are whether domesticated reindeer were present in these communities and if there are differences in the composition and roles of reindeer (Salmi et al. 2015, 2021). The bones in these assemblages are not only fragmented by disarticulation and butchery but also by nature, as taphonomic processes have further fragmented the remains. The prospect of reconstructing the pieces of a single bone, let alone

a single animal, is unthinkable complex. It is from these pieces, then, that groups, activities, and lives must be reconstructed.

Although reindeer can be divided into many categories, studies focus on three types of reindeer that may be present: wild *Rangifer tarandus fennicus* (forest reindeer), herded *Rangifer tarandus tarandus* (herded domestic reindeer), and working *Rangifer tarandus tarandus* (domestic reindeer employed in labor) (Salmi & Niinimäki 2016; Hull et al. 2020). By extracting the identities of reindeer from the assemblage and assessing activity-related patterns of bone growth and pathological lesions, we may determine how difficult or stressful lives were for working animals in these communities (Salmi & Niinimäki 2016; Salmi et al. 2020).

Analyses have already been undertaken on the reindeer pathologies, and research is ongoing. Taking a part of the assemblage (reindeer) and then assessing smaller components (bone and bone fragments) and then assessing smaller aspects of those components (features of bones) is one way that zooarchaeologists can look for signs that point to the physical markers of domestication (Salmi & Niinimäki 2016; Hull 2020; Salmi et al. 2020). In this case, while multiple bones were assessed for pathologies and enthesal changes, the toes of the reindeer can provide a case study for how we can use a part to extrapolate the whole.

Lipping and pathological bone growth around the articular surfaces of limbs provide strong indications of work, as additional stress and weight on the body are transferred to the limbs and feet where they cause pathological lesions and excessive bone growth (e.g. Henderson 2008; Thomas & Johannsen 2011; Salmi & Niinimäki 2016). Patterns of enthesal change on the bones of working animals also differ from those of both wild and herded animals (e.g. Henderson 2008; Salmi & Niinimäki 2016; Hull et al. 2020; Salmi et al. 2020). Toe bones with pathological lesions, as well as those with diagnostic enthesal changes, were found within the assemblage, confirming that working animals were present at both sites (Hull et al. submitted; Salmi et al. 2020). However, we can only tell which pieces of bone show signs of work, but not how these pieces come together to constitute an individual, much less the context of a herd dynamic and a community that included both humans and reindeer employed in various activities. These bones become a symbol, a demarcation of economy and human organisation, but we do not see the whole individual, much less their place within the community. By acting as the representative of a subgroup, individual identity is erased.

A single toe bone is a tiny portion of an animal, but small features on these small bones represent a huge amount of information. Within these small features, signs of work, and unnatural stress, and, therefore, domestication can be seen. However, the holistic health, wellness, and agency of an ancient animal can never be known in its entirety, certainly not from only one tiny, disarticulated portion of their bodies.

Enthesal changes and pathological lesions in working animals are a well-accepted form of analysis of domestication and human use of animals and have been used in various studies (e.g. Thomas & Johannsen 2011; Losey et al. 2014; Salmi & Niinimäki 2016; Latham & Losey 2019; Hull et al. 2020). One aspect that is important to consider but is usually only explored in cases of extreme pathologies is the holistic effects that work causes in these animals, in these human-animal relationships, and in the humans who are working with these animals. Both pathological lesions and activity-based markers take time and repetitive, extensive behaviors to develop, and that does not describe the conditions of all working animals. Some draft animals may work intermittently or pull lighter loads. Some may die or be culled before they develop any skeletal markers of their activity, and some may never develop these conditions. It is therefore highly unlikely to overestimate the presence of working animals in such assemblages; there are likely many invisible working individuals who are not seen in the analysis.

## Discussion

In each of these cases, both quantitative and qualitative methodologies are legitimate tools for zooarchaeological analysis. Unfortunately, the more fragmentary the assemblage, the more we may be unwilling to employ qualitative or individualistic analysis of the individuals at the site, and, likewise, an individual may lead us to ignore the experiences of the greater community of animals. Animal Studies critiques of the processual system do not negate the importance of these analyses and should instead encourage us to develop theoretical depth and breadth in our studies, especially when we are exploring and analyzing types of human-animal entanglements, relationships, and life histories.

On the other hand, quantitative and qualitative analyses of assemblages both run the risk of either over- or underrepresenting subgroups of a population, as we only see glimpses of small parts of lives. In the case of Balto and Togo, their life histories may have been wildly different from those of other unnamed dogs making the run. When looking at an assemblage, this becomes even more complicated. For example, in a mixed and disarticulated assemblage, if there are several bones that show evidence of severe osteoarthritis and pathologies and there are also fused lumbar vertebrae, we may assume that there is one individual who shows evidence of pathologies consistent with being ridden. Alternatively, each of these bones may represent different individuals, all of whom were employed in different kinds of exhaustive activity. There may also be individuals within the assemblage who do not display the physical circumstances of their lives but also life histories typical of many of the individuals present.

We are tasked with deciding to address individual versus communal histories and to ask questions that are directed at each line of inquiry. As we approach analysis with the best of intentions, cognizant of the limitations of our field and of our own analysis, how do we respect the individual while accepting that the use of representative fragments is necessary for scientific rigor? In this sense, novel approaches and theories expand both our ability to answer complex questions and our ability to present new avenues for exploration and thought. There is nothing wrong with focusing on either the greatest whole or the smallest component part. It is, however, important to note that we are doing and why. It may be beneficial to zooarchaeology to use the frameworks of fragmentation theory to think of specimens, animals, animal communities, and multi-species communities as varying degrees of parts and wholes, all inexorably connected to one another.

### **Concluding reflections**

The most distinct disconnect discussed in this paper is the push and pull between considering the individuality and the communality of animal remains. The drive to understand the animal as ‘Individual,’ as a non-human person with agency, experiences, and value, often butts up against the realities of assemblage analysis and the need for statistical probabilities to understand the group as ‘Collective.’

We must face the uncomfortable reality of being denied a single truth. We must consider that a fragment of an individual is both not that individual and more than that individual – both and neither – all at once. In the hands of an analyst, a bone can become representative of many things. With responsible reflexivity, we may focus on the research questions that we seek to answer while acknowledging other truths that may not be investigated within the purview of a single study.

While I have defended the use of processual archaeological techniques as important and valuable, it is noteworthy that the focus on the “pure science” of quantitative zooarchaeological analysis often relegates animals to objects devoid of agency, feeling, or individuality. It is necessary to consider animal agency and animal influence in our studies, as well as traditional cultural knowledge and indigenous understandings of animals, whether this takes the form of the recognition of the personhood of individual animals, the acknowledgment of communal and social animal organisation outside of human control, or the understanding that animals have shaped individual and communal human lives, economies, and cosmologies.

Employing, accepting, and acknowledging multiple ontologies allows us to understand animal lives from multiple perspectives. By considering multiple truths, we can open avenues to new modes of understanding, and, without devaluing our own work, see the value in other frameworks of focus,

thought, and understanding. It is my assertion that the dichotomies of individualism and communalism, of human use and animal-focused life history, and of qualitative and quantitative data are not mutually exclusive. While focusing on the individual lives of both humans and other animals is important in terms of personhood, it is also important to examine the Population as Identity, the One as part of the Collective, representative of the myriad possible roles available to each member of each society.

If we see not just a grain of sand but can look within it at the world it contains, we become more reflexive in our study and allow ourselves to consider different ideas and experiences. An assemblage is constructed of individuals, and if we go forward with care, we can see both the one and the many. Like the seeds within a pomegranate, one pip does not show the whole fruit, but the whole fruit cannot be defined without each pip.

Later in *Auguries of Innocence*, William Blake writes, 'A dog starv'd at his Masters Gate/Predicts the ruin of the State /A Horse misus'd upon the Road/ Calls to Heaven for Human blood' (Blake et al. 1968; 1789–1794). One final, important aspect of zooarchaeology is that the condition of the non-human persons in society reveals much about the changing conditions of the human persons in that society as well. Animals are not just a proxy for humanity but often bellwethers of human society, and explorations of their identities, health, and lives remain an important aspect of human archaeology. As in all scientific pursuits, we will always find ourselves at least partially incorrect; our goal must therefore be to answer our questions as correctly as possible while opening our minds to all possibilities that are conceivable.

## Note

- 1 The 1925 Nome diphtheria run, also known as The Great Race of Mercy, is a famous North American historical event. In the remote town of Nome, Alaska a diphtheria outbreak emerged in the winter of 1924–1925. As ice and snow prevented conventional means of reaching the settlement, relay teams of 20 mushers and over 150 sled dogs travelled the 1,085 km distance in temperatures well below  $-40^{\circ}\text{C}$ . The serum provided by the teams who travelled in relay over 5.5 days from Anchorage, Alaska saved the area from epidemic and is considered one of the great triumphs of perseverance in the face of insurmountable odds. The Iditarod Sled Race is held in honor of this event. It must be noted that this run only saved this community of white settlers; Alaskan Native peoples were devastated by multiple outbreaks which did not receive attention, medication, or support.

## References

- Aaltola, E. 2008. Personhood and animals. *Environmental Ethics* 30(2): 175–193. <https://doi.org/10.5840/enviroethics20083025>
- Aboul-Enein, B.H., Puddy, W.C., & Bowser, J.E. 2019. The 1925 diphtheria anti-toxin run to Nome, Alaska: a public health illustration of human-animal

- collaboration. *Journal of Medical Humanities* 40(3): 287–296. <https://doi.org/10.1007/s10912-016-9428-y>
- Balto not Nome hero dog: Seppala says Husky named Fox was leader of his team. *New York Times*, March 9, 1927 25: 1.
- Bellars, A.R. & Godsall, M.F. 1969. Veterinary studies on the British Antarctic Survey's sledge dogs: II. Occupational osteoarthritis. *British Antarctic Survey Bulletin* 22: 15–38.
- Binford, L.R. 1962. Archaeology as anthropology. *American Antiquity* 28(2): 217–225.
- . 1978. *Nunamiut: ethnoarchaeology*. New York: Academic Press.
- Blake, W. et al. 1968. *Auguries of innocence*. New York: Grossman Publishers.
- Boyd, B. 2017. Archaeology and human-animal relations: thinking through anthropocentrism. *Annual Review of Anthropology* 46: 299–316. <https://doi.org/10.1146/annurev-anthro-102116-041346>
- Brink, J. 2008. *Imagining Head-Smashed-In: aboriginal buffalo hunting on the northern plains*. Athabasca, AB: Athabasca University Press.
- Brink, J. & Dawe, B. 1989. *Final report of the 1985 and 1986 field seasons at Head-Smashed-In Buffalo Jump, Alberta*. Edmonton: Archaeological Survey of Alberta.
- Chapman, J. 2000. *Fragmentation in archaeology: people, places and broken objects in the prehistory of South Eastern Europe*. London: Routledge. <https://doi.org/10.4324/9780203759431>
- Chapman, J.C. & Gaydarska, B.I. 2006. *Parts and wholes: fragmentation in prehistoric context*. Oxford: Oxbow Books.
- Dawkins, M.S. 2008. The science of animal suffering. *Ethology* 114(10): 937–945.
- Dennis, M.M., Stuart, N.N., Cantor, G.H., Mosier, D.A., Blake, J.E. & Basaraba, R.J. 2008. Assessment of necropsy findings in sled dogs that died during Iditarod Trail sled dog races: 23 cases (1994–2006). *Journal of the American Veterinary Medical Association* 232(4): 564–573. <https://doi.org/10.2460/javma.232.4.564>
- Gräslund, A.S. 2004. Dogs in graves—a question of symbolism? In: B. Santillo Frizell (ed.) *Pecus: man and animal in antiquity*. Rome: The Swedish Institute in Rome, 167–176.
- Henderson, C. 2008. When hard work is disease: the interpretation of enthesopathies in M. Brickley & M. Smith (eds) *Proceedings of the Eighth Annual Conference of the British Association for Biological Anthropology and Osteology*. Oxford: Archaeopress, 17–25.
- Hill, E. 2013. Archaeology and animal persons: toward a prehistory of human-animal relations. *Environment and Society* 4(1): 117–136. <http://dx.doi.org/10.3167/ares.2013.040108>
- Hull, E.H., Niinimäki S. & Salmi, A-K. 2020. Differences in enthesal changes in the phalanges between ecotypes of Fennoscandian reindeer. *International Journal of Osteoarchaeology* 30: 666–678. <http://dx.doi.org/10.1002/oa.2897>
- Hull, E., Salmi, A-K., and Semeniuk, M. in press. Activity reconstruction of Rangifer tarandus feet in Fennoscandian archaeology: methodological considerations and application to archaeological material from two Sámi habitation sites. *International Journal of Paleopathology*.
- Kean, H. 2009. Balto, the Alaskan dog and his statue in New York's Central Park: animal representation and national heritage. *International Journal of Heritage Studies* 15(5): 413–430. <http://dx.doi.org/10.1080/13527250903072757>

- Latham, K.J. & Losey, R.J. (2019). Spondylosis deformans as an indicator of transport activities in archaeological dogs: a systematic evaluation of current methods for assessing archaeological specimens. *PLOS ONE* 14(4). <https://doi.org/10.1371/journal.pone.0214575>
- Losey, R.J. et al. 2014. Craniomandibular trauma and tooth loss in northern dogs and wolves: implications for the archaeological study of dog husbandry and domestication. *PLoS One* 9(6). <https://doi.org/10.1371/journal.pone.0099746>
- Losey, R.J. et al. 2018. Domestication and the embodied human-dog relationship: archaeological perspectives from Siberia. In: R.J. Losey et al. (eds) *Dogs in the north: stories of cooperation and co-domestication*. London: Routledge, 8–27.
- MacKinnon, M. 2010. ‘Sick as a dog’: zooarchaeological evidence for pet dog health and welfare in the Roman world. *World Archaeology* 42(2): 290–309.
- McMillan, F.D. 2008. *Mental health and well-being in animals*. Hoboken, NJ: Wiley-Blackwell.
- Nyysönen, J. & Salmi, A-K. 2013. Towards a multiangled study of reindeer agency, overlapping environments, and human-animal relationships. *Arctic Anthropology* 50(2): 40–51.
- Opp, J. 2013. Public history and the fragments of place: archaeology, history and heritage site development in southern Alberta. In: J. DeGroot (ed.) *Public and popular history*. London: Routledge, 101–128.
- Poliquin, R. 2011. *Balto the Dog*. In: S.J.M.M. Alberti (ed.) *The afterlives of animals: a museum menagerie*. Charlottesville: University of Virginia Press.
- Puputti, A.K. 2008. A zooarchaeology of modernizing human-animal relationships in Tornio, northern Finland, 1620–1800. *Post-Medieval Archaeology* 42(2): 304–316. <https://doi.org/10.1179/174581308X381029>
- Reitz, E.J. & Wing, E.S. 1999. *Zooarchaeology*. Cambridge: Cambridge University Press.
- Salisbury, G. & Salisbury, L. 2003. *The cruelest miles: the heroic story of dogs and men in a race against an epidemic*. New York: WW Norton & Company.
- Salmi A-K. & Niinimäki, S. 2016. Enteseal changes and pathological lesions in draught reindeer skeletons – four case studies from present-day Siberia. *International Journal of Paleopathology* 14: 91–99. <https://doi.org/10.1016/j.ijpp.2016.05.012>
- Salmi A-K. et al. 2015. Animal offerings at the Sámi offering site of Unna Saiva – changing religious practices and human–animal relationships. *Journal of Anthropological Archaeology* 40: 10–22. <http://orcid.org/0000-0003-0332-7351>
- Salmi A-K. et al. 2020. Identification of working reindeer using palaeopathology and enteseal changes. *International Journal of Paleopathology* 30: 57–67. <https://doi.org/10.1016/j.ijpp.2020.02.001>
- Salmi, A-K. et al. 2021. Earliest archaeological evidence for domesticated reindeer economy among the Sámi of Northeastern Fennoscandia AD 1300 onwards. *Journal of Anthropological Archaeology* 62: 101303. <https://doi.org/10.1016/j.jaa.2021.101303>
- Stammler, F. & Takakura, H. (eds). 2010. *Good to eat, good to live with: nomads and animals in Northern Eurasia and Africa*. *Northeast Asian Study Series 11*. Sendai: Center for Northeast Asian Studies, Tohoku University.
- Steele, T.E. 2015. The contributions of animal bones from archaeological sites: the past and future of zooarchaeology. *Journal of Archaeological Science* 56: 168–176. <https://doi.org/10.1016/j.jas.2015.02.036>

- Thomas, B. & Thomas, P. 2015. *Leonhard Seppala : the Siberian dog and the golden age of sleddog racing 1908–1941*. Missoula, Montana: Pictorial Histories Publishing Company.
- Thomas, R. & Johannsen, N. 2011. Articular depressions in domestic cattle phalanges and their archaeological relevance. *International Journal of Paleopathology* 1(1): 43–54. <https://doi.org/10.1016/j.ijpp.2011.02.007>
- Tourigny, E. et al. 2016. An osteobiography of a 19th-century dog from Toronto, Canada. *International Journal of Osteoarcheology* 26(5): 818–829. <https://doi.org/10.1002/oa.2483>
- Watts, C. (ed.) 2014. *Relational archaeologies: humans, animals, things*. New York: Routledge.
- Zeder, M.A. 2006. *Documenting domestication: new genetic and archaeological paradigms*. Berkeley: University of California Press.

# 10

## FRAGMENTED REINDEER OF STÁLLO FOUNDATIONS

A multi-isotopic approach to fragmented reindeer skeletal remains from Adámvallda in Swedish Sápmi

*Markus Fjellström*

### Introduction

Reindeer (*Rangifer tarandus*) has had a wide geographic and chronological presence in Fennoscandia (i.e. the Scandinavian and Kola peninsulas, mainland Finland and Karelia). From palaeolithic bog finds after the Ice loss in southern Sweden (Larsson 1994) to ecological skeletal remains from melting glaciers and snow patches, as well as archaeological finds of reindeer at Sámi and non-Sámi archaeological sites (i.e. Stállo foundations, hearth-row sites, pitfalls, market places...), it can be seen that the reindeer has been present under different forms and circumstances. The often deliberately fragmented reindeer skeletal remains, for example, in the form of bones split to access the marrow, illuminate the economic importance of reindeer through time. Nevertheless, it is not always clear that the reindeer skeletal fragments were deliberately broken; it is possible that some were non-deliberately fragmented. The focus of this study is the deliberate or non-deliberate breakage and depositing of reindeer skeletal elements.

In this study, I will concentrate on Stállo foundations in Sápmi that are found in the borderlands between present-day Norway, Sweden and Finland. The few fragmented objects that have been found are intriguing and worth some attention. Here, I will use radiocarbon and stable isotope analysis on fragmented reindeer skeletal remains to engage in a discussion on food and the practices of fragmentation. Bearing in mind that each part of the reindeer carcass has a certain value and that the fragmentation of an animal can be used as an analogy for human relations (Chapman 2000:40), the fragments in this study each carry their own story that I will try to approach.

Relating to previous interpretations of the Stållo foundations, either as hunting stations or the remains of an intensification of reindeer domestication and an early Sámi pastoral society (Mulk 1994; Hedman 2003, 2015; Bergman et al. 2008, 2013; Sommerseth 2009), I am here interested in the role that the distribution of reindeer, as a raw material and a *social* animal in relation to humans, might have had. This is studied not merely through *the creation, maintenance and development of social relations* (Chapman 2000), but rather as a product of social interactions between humans as well as between humans and reindeer. To do so, I will investigate the diet, mobility and seasonality of reindeer found at Stållo foundations in Adamvalldá (Figure 10.1) by using radiocarbon ( $^{14}\text{C}$ ) and stable isotope analysis ( $\delta^{13}\text{C}$ ,  $\delta^{15}\text{N}$ ,  $\delta^{34}\text{S}$  and  $^{87}\text{Sr}/^{86}\text{Sr}$ ).

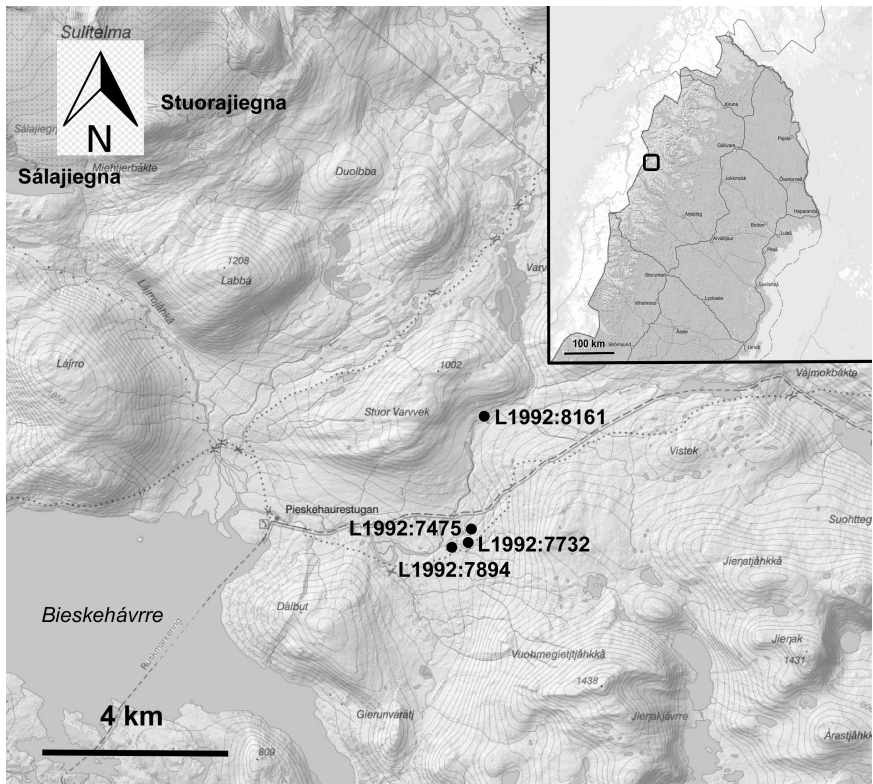

FIGURE 10.1 The map shows the four sites from Adámvalldá, Arjeplog parish, Sweden, by the Norwegian border (L1992:7475, L1992:7732, L1992:8161 and L1992:7894) (Liedgren 2003a, 2003b, 2004). The map has been retrieved and reworked from Lantmäteriet (© Lantmäteriet 2022).

### Stállo foundations – what were they used for?

A stállo foundation is defined as a hut construction with a sunken floor, up to 0.25 m in depth; the size varies but is approximately 4 × 4 m, and it is surrounded by an elevated embarkment up to 8.5 m. In the middle of the foundation is the hearth, referred to as árran in Sámi (Mulk 1994; Storli 1994; Hedman 2003; Liedgren et al. 2007; Liedgren & Bergman 2009). These constructions are linked to a Viking Age or early medieval Sámi pastoral or wild reindeer hunting society.

Stállo foundations are commonly known to be traces left from Sámi activities, even though there has been discussion on whether they could have been used by Norsemen and Norse chieftains for trade, hunting, and taxing the Sámi population (Kjellström 1983). Today, the theory of Stállo settlement sites as occupation sites of Norsemen has been dismissed (Bergman et al. 2008; Hedman 2015:35). Some researchers argue that these foundations were used seasonally by wild reindeer hunters (Hansen 1990; Mulk 1994; Storli 1994; Sommerseth 2011). For instance, Ingrid Sommerseth (2011:120) interpreted the Stállo foundations to have been used during late summer and autumn in connection with wild reindeer hunts. Others have argued that pitfalls are present close by and were used by the same people who built the Stállo foundations. Conversely, some researchers have argued that the lack of pitfalls in the vicinity is remarkable since, in relation to the hunting of wild reindeer, such sites could be presumed to be found nearby (Hedman & Olsen 2009:10; Hedman 2015:43).

Another interpretation of the Stállo foundations is that they are markers for the beginning of an intensification of reindeer herding and are part of a pastoral society and societal change (Bergman et al. 2008). They represent a time of change within the Sámi community from a hunting to a herding society. Through pollen analysis from Stállo foundations in Adámvallda and nearby areas, researchers also argue that the tree line was higher up in the Late Iron Age (LIA) and Early Middle Ages and that this was a prerequisite for the existence of these foundations, both for their construction and for fuel (Bergman et al. 2013:33). Due to the overexploitation of the forest in the alpine areas and the increasing number of domesticated reindeer by the end of the Iron Age and the beginning of the Middle Ages, the Sámi community started to divide into smaller groups (Liedgren et al. 2007; Bergman et al. 2013:36). It is further suggested that the foundations were used during the winter by reindeer herders who stayed on the mountain ridge throughout the whole year (Liedgren & Bergman 2009:23).

In addition, other archaeological features can be connected to the Stállo foundations. These are, for example, the remains of food storage (Hedman 2015:37), such as storage pits or/and *burra* (storage pit). The latter has also been interpreted to have been used to make offerings to the gods (Hedman

2015). On that note, Sámi offerings of metal objects, as well as wild and domesticated fauna, were common and widespread across the landscape (Serning 1956; Salmi et al. 2015). According to Salmi et al. (2015:108), offerings of reindeer began to be more frequent in the 13th century as the number of domesticated reindeer seemed to have increased. Before that, it was more common to offer other wild fauna. In addition, archaeo-ethnographical sources mention reindeer milking and finds of reindeer bones split to access the marrow, which is a good example of a well-known and well-documented occurrence within Sámi communities related to food consumption (e.g. Drake 1918; Eidlitz 1969; Mulk 1994; Hedman 2003; Olsen 2010; Hedman et al. 2015; Liedgren et al. 2016).

Bergman et al. (2013:30) dated 29 hearths in the Adámvallda areas to a time span ranging from c. 600 to 1900 CE, with a concentration of hearths dating to the 16<sup>th</sup> and 17<sup>th</sup> centuries. They argue that the spatial distribution of hearths, which are not part of any Stállo foundation, represents a higher degree of mobility and adaptation to a more sustainable land use, for example, due to restricted access to fuel (Bergman et al. 2013:35). They also connect these changes of cultural expression in the archaeological features and remains to a long-term re-organisation of the societies in these areas, from a society more based on hunting to herding.

In connection with some of the Stállo foundations, there are finds of bone caches and hearths (Mulk 1994; Hedman 2015:39). In an archaeological survey project on Sámi archaeological and cultural remains, 129 stállo foundations were registered in the Lønsdal/Saltfjellet areas in Norway. Furthermore, there were 23 bone caches and 31 storage pits (Hedman 2015:40). Storli (1994) and Hedman (2015) find it remarkable that there are no pitfalls in this area, despite an appropriate landscape for such sites. Some of the skeletal remains from bone caches in Hedman's investigation were radiocarbon dated (Hedman 2015:46). The purpose of hiding reindeer bones can have been for practical reasons, such as to clean the area and hide the bones away, or, as in the case of offering sites, there might have been a religious purpose, for example, offering reindeer bones for good herding luck (Hedman 2015:46). The few resulting dates published (Hedman 2015) were later than the 12th century. However, as the author also discusses, the skeletal remains collected for radiocarbon dating might represent a later phase, and skeletal remains from earlier layers might be contemporaneous to the Stállo foundations. Here, further discussion and investigation could elucidate if there is any connection between bone caches and other contemporaneous features.

To summarise, research has shown that Stállo foundations seem to have been used for, and in connection with, hunting, accessing raw materials, trade, as well as to produce food and store it. They were part of a pastoral way of life, not least in relation to milking reindeer or using domesticated

reindeer as a decoy for hunting wild reindeer. It is nonetheless intriguing that the findings are few and that there are still *mysteries* behind the story of the Stållo foundations.

## Material

In this study, I have selected unburnt reindeer skeletal remains from three of the 31 Stållo foundation sites and from one hearth in Adámvallda (Liedgren et al. 2007:1278) in order to study reindeer diet and mobility. The selected Stållo foundations were L1992:7732 (SMA 67:3), L1992:7475 (SMA 68:1) (Liedgren 2003a), L1992:8161 (SMA 168:2) (Liedgren 2003b) and the hearth L1992:7894 (SMA 302:2) (Liedgren 2004). Some of them contained other artefacts, such as burned bones, yellow pyrite, a piece of quartz, iron fragments (interpreted as a razor blade), a fragment of soapstone, a fire-cracked piece of flint, pieces of leather and an iron arrow head interpreted as a combat arrow, unique in northern Sweden (Liedgren 2003a; Liedgren 2003b; Liedgren 2004) (Table 10.1).

The selected material for this study has been compared with previously published data on reindeer skeletal remains (Salmi et al. 2015; Fjellström et al. 2019, 2021) (Table 10.1, Figures 10.2a and 10.2b).

## Method

### $\delta^{13}\text{C}$ , $\delta^{15}\text{N}$ and $\delta^{34}\text{S}$

The stable isotopes carbon, nitrogen and sulphur ( $\delta^{13}\text{C}$ ,  $\delta^{15}\text{N}$  and  $\delta^{34}\text{S}$ ) are generally used in archaeology to study faunal and human diet and mobility. The  $\delta^{13}\text{C}$  isotope value is determined by the photosynthetic pathway that different plants use or by the dissolved carbonate in marine environments (Sealy 2001:270). The most common photosynthetic pathway in our region is  $\text{C}_3$ . For each trophic level,  $\delta^{13}\text{C}$  values increase by c. 1‰ (DeNiro & Epstein 1978). In general,  $\delta^{13}\text{C}$  is used to study terrestrial vs. marine dietary intake. The  $\delta^{15}\text{N}$  isotope value can vary depending on several different factors: the trophic level, physiology, stress, climate and environment (DeNiro & Epstein 1978; Ambrose 1990; O’Connell & Hedges 1999). For each trophic level, the  $\delta^{15}\text{N}$  isotope value increases by c. 3–5‰ (Minagawa & Wada 1984; Bocherens & Drucker 2003). The  $\delta^{34}\text{S}$  isotope value varies depending on the local geology of the bedrock as well as between different terrestrial and marine environments (Krouse 1980:436; Richards et al. 2003; Faure & Mensing 2005). In coastal areas, the  $\delta^{34}\text{S}$  isotope value of an individual feeding solely on terrestrial plants can be affected by the so-called sea-spray effect, which can alter the  $\delta^{34}\text{S}$  isotope value towards a more marine value (Nehlich 2015). Trophic level shifts in  $\delta^{34}\text{S}$  are still heavily debated (e.g. Nehlich 2015, Webb et al. 2017).

Collagen was extracted from the bones and antlers of both archaeological and modern reindeer using the modified Longin method (Brown et al. 1988). An amount of 0.4–0.6 mg of collagen for carbon and nitrogen isotope analysis and 5.6–8.5 mg for sulphur isotope analysis was weighed in tin capsules and measured in a mass spectrometer. We also used 1.0–2.9 mg for radio-carbon dating. Carbon and nitrogen isotopes were analysed at the Department for Geological Sciences at Stockholm University and combusted in a CarloErba NC2500 elemental analyser connected to a mass spectrometer (continuous flow IRMS) – a Finnigan DeltaV Advantage – with a precision of  $\pm 0.15\%$  or better for both  $\delta^{13}\text{C}$  and  $\delta^{15}\text{N}$ . Later, in order to correct for a possible effect of lipid residue, we removed lipids from previously analysed samples and then analysed them again at the Mass Spectrometry Laboratory at Vilnius University, using a Flash EA 1112 Series Elemental Analyzer that was connected to a Delta V Advantage Isotope Ratio Mass Spectrometer (IRMS) via a ConFlo III Interface with a precision of  $\pm 0.1\%$  for both  $\delta^{13}\text{C}$  and  $\delta^{15}\text{N}$ . Sulphur isotopes were analysed at Iso-Analytical using a Sercon CNS-EA Elemental Analyser Auto-Sampler linked to a Europa Scientific 20-20 Isotope Ratio Mass Spectrometer with a precision of 0.3%. All stable isotope values are expressed per mille (‰).

### *Strontium isotope*

Strontium isotope analysis is used to study general and seasonal mobility among humans and animals (e.g. Ericson 1985; Britton 2009; Glykou et al. 2018; Fjellström et al. 2022). Strontium does not undergo any extensive fractionation (Bentley 2006:141), which makes it suitable for mobility and migration studies. In theory, the strontium isotope ratio ( $^{87}\text{Sr}/^{86}\text{Sr}$ ) analysed in any bone, dentine, or enamel is representative of the bioavailable strontium in plants and water ingested at the time of tissue formation. Hence, the strontium isotope ratio reflected in any reindeer skeletal element in this study should reflect the strontium taken up by the plant the reindeer has eaten and therefore the local bedrock where the plant has been growing.

Three soil and three plant samples were put under UV light for 1.5 hours, then sieved and weighed. The same amount of water samples ( $n = 3$ ) were collected in acid-cleaned bottles. All references were measured for  $^{87}\text{Sr}/^{86}\text{Sr}$  at the Swedish Museum of Natural History in Stockholm. All samples were analysed with a Thermo Scientific Triton TIMS using a load of purified samples mixed with tantalum activator on a single rhenium filament. Measured  $^{87}\text{Sr}$  intensities were corrected for Rb interference using  $^{87}\text{Rb}/^{85}\text{Rb} = 0.38600$ , and ratios were reduced using the exponential fractionation law and  $^{88}\text{Sr}/^{86}\text{Sr} = 8.375209$ . The external precision for  $^{87}\text{Sr}/^{86}\text{Sr}$  based on repeat runs of the NBS 987 standard was 18 ppm ( $n = 20$ ). The values were normalised against the NBS 987 standard.

## Results

### *Stable isotope analysis*

All samples gave collagen of good quality (van Klinken 1999) and fulfilled the quality criteria (DeNiro 1985; Ambrose 1990; Nehlich & Richards 2009). The  $\delta^{13}\text{C}$  values for the reindeer in this study range between  $-20.1\text{‰}$  and  $-17.9\text{‰}$  with a mean value and standard deviation of  $-19.4 \pm 1.0\text{‰}$ . The  $\delta^{15}\text{N}$  values vary between  $2.0\text{‰}$  and  $3.3\text{‰}$  with a mean value and standard deviation of  $2.6 \pm 0.5\text{‰}$ . The low  $\delta^{15}\text{N}$  values reflect the expected dietary intake for reindeer (e.g. Fjellström et al. 2020, accepted and Salmi et al. 2020). The  $\delta^{34}\text{S}$  values range between  $8.5\text{‰}$  and  $10.4\text{‰}$  with a mean value and standard deviation of  $9.4 \pm 0.8\text{‰}$  (Figures 10.2a and 10.2b, Table 10.1).

The  $^{87}\text{Sr}/^{86}\text{Sr}$  values of the reindeer bones were 0.72263 (ADA 1) and 0.72994 (ADA 2). The strontium concentration for all measurements was between 96.5 and 154 ppm (Table 10.1). In addition, water, plants, and soil from Sálajiegna and Stuorajiegna (Figure 10.1) were analysed to establish the bioavailability of strontium using TIMS, with values ranging from 0.71354 (water) to 0.72356 (soil).

### *Radiocarbon analysis*

The unburnt reindeer samples (ADA 1–4) from the three different Stållo foundations and the one hearth were radiocarbon dated at the Ångström laboratory, Uppsala University. One sample (ADA 1) was dated to the Viking Age (775–973 cal CE) and coincides with the previous dating of the hearth of L1992:7475 (Liedgren et al. 2007:1280–1281). The other three unburnt bone samples date from a period between 1648 and 1949 cal CE. Interestingly, only the hearth (ADA 4) coincides with its previous dating (1666–... cal CE). The previous dating of charcoal from L1992:7732 (1317–1636 cal CE) and the unburnt reindeer bone (ADA 2, 1679–1940 cal CE) found at the site display either a continuous use of the hearth or two very separate events. The Stållo foundation at L1992:8161, dated to a period between 678 and 1021 cal CE, does not coincide at all with the dating of the unburnt reindeer bone (ADA 3, 1664–1949 cal CE) (Table 10.1). This later dating suggests, as Liedgren et al. (2007:1281) have argued for, a secondary use of the hearth. However, the different dates of the skeletal remains and the charcoal indicate a long continuity of use at the site.

## Discussion

Chapman and Gaydarska (2007:203–204) suggest an approach involving enchainment where it is important to explore the development of a more

**TABLE 10.1** Results from the stable carbon, nitrogen, sulphur and strontium isotope analysis of the reindeer skeletal remains from Adámvallda. Results of the quality assessment are also added to the table (concentrations of carbon, nitrogen, sulphur and strontium, as well as C:N, C:S and N:S ratios). Information about the finds from each Stállo foundation and hearth is added. Previous radiocarbon results are from Liedgren et al. 2007

Sample #	Find #	L-number	Previous dates (cal CE)	<sup>14</sup> CNew dates this study (cal CE)	Element sampled	Collagen (%)	$\delta^{13}\text{C}$ (‰)	$\delta^{15}\text{N}$ (‰)	$\delta^{34}\text{S}$ (‰)	C (%)	N (%)	S (%)	C:N	C:S	N:S	<sup>87</sup> Sr/ <sup>86</sup> Sr	<sup>87</sup> Sr/ <sup>86</sup> Sr (ext. precision)	Sr conc. (ppm)
ADA 1	F3	L1992:7475	776–998	775–973	Cornu	4.4	-17.9	2.0	10.4	36.9	13.0	0.21	3.3	469	165	0.722631	0.000013	97
ADA 2	F3	L1992:7732	1317–1636	1679–1940	Femur	8.1	-19.8	3.3	9.0	37.8	13.4	0.23	3.3	439	155	0.729936	0.000013	154
ADA 3	F1	L1992:8161	678–1021	1664–1949	Femur	4.3	-19.7	2.4	9.6	37.9	13.4	0.22	3.3	460	162	-	-	-
ADA 4	F4	L1992:7894	1666–...	1648–1949	Humerus	2.7	-20.1	2.7	8.5	38.2	13.4	0.25	3.3	408	143	-	-	-
J21	-	-	-	-	Soil	-	-	-	-	-	-	-	-	-	-	0.715717	0.000013	167
P21	-	-	-	-	salix (plant)	-	-	-	-	-	-	-	-	-	-	0.713621	0.000013	171
V21	-	-	-	-	H <sub>2</sub> O	-	-	-	-	-	-	-	-	-	-	0.713538	0.000013	0.04
J22	-	-	-	-	Soil	-	-	-	-	-	-	-	-	-	-	0.723559	0.000013	121
P22	-	-	-	-	salix (plant)	-	-	-	-	-	-	-	-	-	-	0.721607	0.000013	85
V22	-	-	-	-	H <sub>2</sub> O	-	-	-	-	-	-	-	-	-	-	0.714578	0.000013	0.09
						Mean	-19.4	2.6	9.4							Mean	0.717103	
						S.d.	1.0	0.5	0.8							S.d.	0.003981	
						Min	-20.1	2.0	8.5							Min	0.713538	
						Max	-17.9	3.3	10.4							Max	0.723559	

socially attentive *chaîne opératoire* for all kinds of materials. Studying the *chaîne opératoire* of Stállo foundations, where the main use was either as a hunting station or a more sedentary dwelling site, the reindeer bones found at hearths are most probably the result of food consumption; selection of reindeer for slaughtering, nutrition and production is suggested. Bones split to access the marrow found at one site would suggest activities related to slaughter and nutrition. On the other hand, these bones are dated to a period after the use of the Stállo foundations, indicating a secondary use of the site, as already suggested by Liedgren et al. (2007), possibly linked to herding practices. The find of an antler from the LIA implies a different activity that can be, for example, linked to the production of tools such as combs, spoons, dice, needles, etc. (Van Riel 2017:165).

The isotopic data in this study show that there are both similarities and differences between reindeer from the selected sites (Figure 10.2a). As herbivores, the diet of reindeer stands out since they consume a higher percentage of lichen (>50%), which might affect the  $\delta^{13}\text{C}$  isotopic value positively and the  $\delta^{15}\text{N}$  isotopic value negatively (Britton 2009; Fjellström et al. 2020; Salmi et al. 2020). Three reindeer (ADA 2–4) of historical date, 1648–1949 cal CE, which probably lived during the Little Ice Age (i.e. 17th to mid-19th centuries, see Kaufman et al. 2009:1238–1239), have both low  $\delta^{13}\text{C}$  values (>–19.7‰) and low  $\delta^{15}\text{N}$  values (<3.3‰). This suggests that lichen would not have been the main dietary intake of these reindeer. One explanation is that they had difficulties accessing lichen under the snow cover (Routier 2009:48–50). According to Drucker et al. (2003:169), reindeer feeding on less lichen could result in a greater degree of negative  $\delta^{13}\text{C}$  values. It has been argued that elevated  $\delta^{15}\text{N}$  values might be an effect of foddering (Fjellström et al. 2020; Salmi et al. 2020), which has been shown among reindeer from Forest Sámi reindeer herding districts that did not move over any larger areas. In contrast, reindeer from Mountain Sámi reindeer herding districts that did move over larger areas had low  $\delta^{15}\text{N}$  values (Fjellström et al. accepted). Even though the reindeer have not been foddered in any substantial way, we cannot exclude the possibility that they were domesticated reindeer. Other biological, physiological, and environmental factors might have had an impact on the isotope values (Nieminen & Pietilä, 1999; Drucker et al., 2003, 2012; Parker et al., 2005; Barboza & Parker, 2006).

ADA 1, dated to the LIA, has a high  $\delta^{13}\text{C}$  value (–17.9‰) and a low  $\delta^{15}\text{N}$  value, suggesting that it had different feeding patterns. It is known that reindeer, grazing at higher altitudes exhibit an increase in  $\delta^{13}\text{C}$  values and a decrease in  $\delta^{15}\text{N}$  values (Drucker et al. 2012:325–327). Furthermore, ADA 1 has similar isotopic values to reindeer from Silbajähkkå (Fjellström et al. 2021), situated in a high alpine area c. 630 km SSE of Adámvallda, in contrast to reindeer from the Sámi offering site of Unna Saiva, situated in a Forest Sámi reindeer herding area and displaying elevated  $\delta^{15}\text{N}$  values.

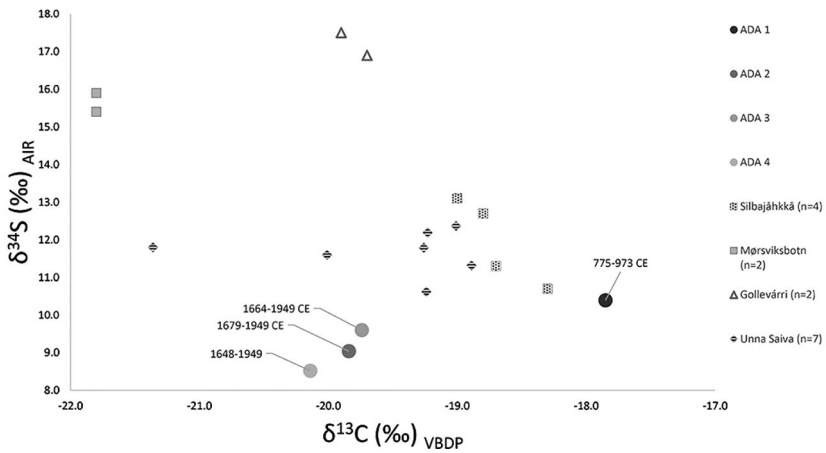
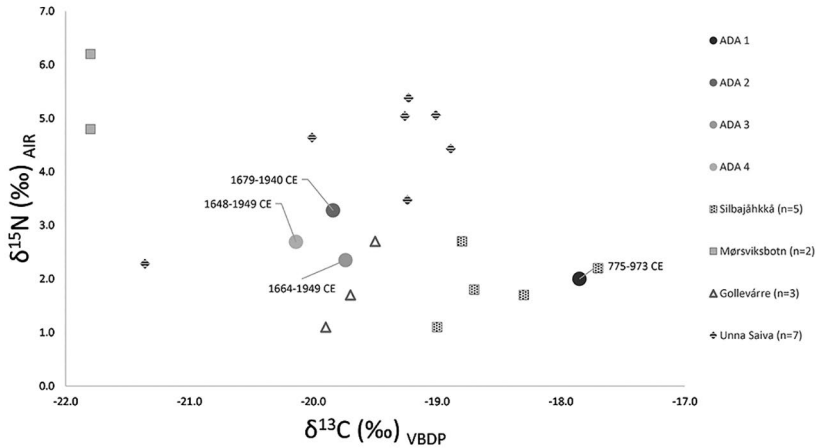

**FIGURE 10.2A** Carbon and nitrogen isotope values for the studied reindeer skeletal remains. Comparative isotope data has been added from Unna Saiva, Silbajåhkkå, Mørsviksbotn and Gollevárri (Salmi et al. 2015; Fjellström et al. 2019, 2021).

**FIGURE 10.2B** Carbon and sulphur isotope values for the studied reindeer skeletal remains. Comparative isotope data has been added from Unna Saiva, Silbajåhkkå, Mørsviksbotn and Gollevárri (Salmi et al. 2015; Fjellström et al. 2019, 2021).

The  $\delta^{34}\text{S}$  values do not vary significantly. However, there is a small difference between the LIA reindeer ADA 1 and the two historical reindeer, ADA 2 and 4, suggesting that they might have been grazing in different geographical areas. Higher  $\delta^{34}\text{S}$  values, such as for Gollevárri and Mørsviksbotn by the

Norwegian coast (Figure 10.2b), which can be explained by a so-called sea-spray effect (Wadleigh et al. 1994; Nehlich, 2015), would have been expected for reindeer residing at the coast. This is not the case here, and reindeer from Adámvallda have most probably not been migrating to the Atlantic coast. In addition, the  $^{87}\text{Sr}/^{86}\text{Sr}$  data indicate that the reindeer ADA 1 and ADA 2 did not reside in the same area. ADA 1 has similar  $^{87}\text{Sr}/^{86}\text{Sr}$  data (0.722631) to the local bioavailable strontium from the nearest glacial area (Stuorajiegna and Sálajiegna: 0.71354–0.72356), which is situated between c. 6 and 10 km from the different Stállo foundations at Adámvallda (Figure 10.1), suggesting that ADA 1 lived at and in the surroundings of Adámvallda. ADA 2, on the other hand, with different  $^{87}\text{Sr}/^{86}\text{Sr}$  values and dated to 1679–1940 cal CE, could be the result of other practices, since the people who dropped or left this fragment of reindeer at the site brought it from another place. Whether or not it is a wild or domesticated reindeer, this is a time with well-established reindeer herding practices and territorial divisions (Liedgren et al. 2007; Bergman et al. 2013), suggesting another scale of mobility with different practices, nonetheless connected to reindeer herding.

The fragmented antler (ADA 1) does not have any traces of production, nor could it be seen if it was part of a shed antler or part of the cranium from a slaughtered reindeer. Hence, it could have been part of a variety of social practices, such as hunting, gathering shed antlers, or, for example, producing objects from raw materials for personal use or trade. On the other hand, the arrowhead found in close connection to the fragmented antler implies that people residing near the Stállo foundations at Adámvallda practised hunting. Finds of arrowheads in high alpine areas are scarce, but it is known from written as well as archaeological and ethnographic sources that the Sámi caught wild reindeer using a lasso or hunted them with a bow and arrow (Ryd 2014:17–18). Based on the finds and some researchers arguments on the use of Stállo foundations as hunting stations, this specific reindeer could have been hunted and brought to Adámvallda. However, more sampling is necessary, and more stable isotope and radiocarbon analysis of reindeer skeletal remains from Stállo foundations and hearths could give some further indication of their use.

In my opinion, the human and reindeer entanglement here is a *profane* relationship. It is not to be compared with the well-known Sámi bear ceremony and feast (Sommersteth 2021) or the offerings of reindeer made at Sámi offering sites (Mebius 2003). However, I cannot disregard the fact that most of the reindeer carcass is missing. Considering the different dimensions of reindeer as a product, the missing parts of the same reindeer from the Stállo foundation could have been included in different distribution patterns and various social practices (i.e. fur trade, offerings, storage, or simply food to be eaten). The lack of bone as organic material could also be explained through taphonomic processes and degradation. Furthermore, due to the lack of other materials, it has been suggested that the Stállo foundations were

cleaned (Liedgren et al. 2007). Are the fragments of reindeer present at the sites in this study only the remains of a poorly cleaned space? The material in this study is scarce, and there is a need to broaden the sample size. Additional oxygen stable isotope analysis ( $\delta^{18}\text{O}_p$ ) to study environmental and climatic changes, as well as more research into different archaeological features such as offering sites, bone caches, etc., could further elucidate the mystery of Stállo foundations.

## Conclusion

In this study, three bones and one antler were radiocarbon dated to a time span between 775 and 1949 cal CE, permitting the study of the diet and mobility of four different reindeer over a longer period. Even though this study does not differentiate between domesticated and wild reindeer, it has been shown that reindeer from different time periods had different  $\delta^{13}\text{C}$ - and  $\delta^{15}\text{N}$  values and that they were from different geographical areas ( $\delta^{34}\text{S}$  and  $^{87}\text{Sr}/^{86}\text{Sr}$ ), both from Adámvallda and its closest vicinity and beyond. As there is no evidence of foddering, the analysis instead provides an insight into reindeer grazing and environmental changes. The results also gave an insight into different known practices over time.

In a discussion on the use of objects after their breakage, Chapman and Gaydarska (2007:87), referring to the *chaîne opératoire*, state that researchers rarely look into where “the missing pieces are?”. Methods within archaeological science are a good way of examining the missing parts of the social function(s) of Stállo foundations. Here, a multi-isotopic approach on a few reindeer skeletal remains has shown the potential for achieving a deeper understanding of the use of Stállo foundations. Nonetheless, more sampling and analysis of Stállo foundations and other features is needed, as are archaeological excavations.

## Acknowledgement

I thank Göran Gustafsson Stiftelse för natur och miljö i Lappland (#2110), the European Research Council (ERC-StG 756431) and the Academy of Finland (Grant 285774) for financing this study. I acknowledge the Swedish Research Council (VR) for financial support of the NordSIMS-Vegacenter national research infrastructure (Grant 2021-00276). This is Vegacenter publication #062.

## References

- Ambrose, S.H., 1990. Preparation and characterization of bone and tooth for isotopic analysis. *Journal of Archaeological Science* 17: 431–451. [https://doi.org/10.1016/03054403\(90\)90007-R](https://doi.org/10.1016/03054403(90)90007-R)

- Barboza, P.S. & Parker, K.L. 2006. Body protein stores and isotopic indicators of N balance in female reindeer (*Rangifer tarandus*) during winter. *Physiological and Biochemical Zoology* 79(3): 628–644. <https://doi.org/10.1086/502811>
- Bentley, A. R. 2006. Strontium isotopes from the Earth to the archaeological skeleton: A review. *Journal of Archaeological Method and Theory* 13(3): 135–187.
- Bergman, I. et al. 2008. Kinship and settlements: Sami residence patterns in the Fennoscandian Alpine areas around A.D. 1000. *Arctic Anthropology* 45(1): 97–110. <https://doi.org/10.1353/arc.0.0005>
- Bergman, I. et al. 2013. From hunting to herding: land use, ecosystem processes, and social transformation among Sami AD 800–1500. *Arctic Anthropology* 50(2): 25–39.
- Bocherens, H. & Drucker, D. 2003. Trophic level isotopic enrichment of carbon and nitrogen in bone collagen: case studies from recent and ancient terrestrial ecosystems. *International Journal of Osteoarchaeology* 13: 46–53. <https://doi.org/10.1002/oa.662>
- Britton, K. 2009. *Multi-isotope analysis and the reconstruction of prey species palaeomigrations and palaeoecology*. Durham theses, Durham University. Available at Durham E-Theses Online: <http://etheses.dur.ac.uk/216/>
- Brown T.A. et al. 1988. Improved collagen extraction by modified Longin method. *Radiocarbon* 30(2): 171–177. <https://doi.org/10.1017/S0033822200044118>
- Chapman, J. 2000. *Fragmentation in archaeology: people, places and broken objects in the prehistory of South Eastern Europe*. London: Routledge. <https://doi.org/10.4324/9780203759431>
- Chapman, J. & Gaydarska, B. 2007. *Parts and wholes. Fragmentation in prehistoric context*. Oxford: Oxbow.
- DeNiro, M.J. & Epstein, S. 1978. Influence of diet on the distribution of carbon isotopes in animals\*. *Geochimica et Cosmochimica Acta* 42: 495–506. [https://doi.org/10.1016/0016-7037\(78\)90199-0](https://doi.org/10.1016/0016-7037(78)90199-0)
- DeNiro, M.J. 1985. Post mortem preservation and alteration of in vivo bone collagen isotope ratios in relation to palaeodietary reconstruction. *Nature* 317: 806–809.
- Drake, S. 1918. *Västerbottenslapparna under förra hälften av 1800-talet*. Uppsala: Almqvist & Wiksells.
- Drucker, D. et al. 2003. Evidence for shifting environmental conditions in South-western France from 33 000 to 15 000 years ago derived from carbon-13 and nitrogen-15 natural abundances in collagen of large herbivores. *Earth and Planetary Science Letters* 216: 163–173. [http://dx.doi.org/10.1016/S0012-821X\(03\)00514-4](http://dx.doi.org/10.1016/S0012-821X(03)00514-4)
- Drucker, D. et al. 2012. Environmental context of the Magdalenian settlement in the Jura Mountains using stable isotope tracking ( $^{13}\text{C}$ ,  $^{15}\text{N}$ ,  $^{34}\text{S}$ ) of bone collagen from reindeer (*Rangifer tarandus*). *Quaternary International* 272–273: 322–332. <https://doi.org/10.1016/j.quaint.2012.05.040>
- Eidlitz, K. 1969. *Food and emergency food in the circumpolar area*. Uppsala: Almqvist & Wiksells bottryckeri AB.
- Ericson, J.E. 1985. Strontium isotope characterization in the study of prehistoric human ecology. *Journal of Human Evolution* 14(5): 503–514. [https://doi.org/10.1016/S0047-2484\(85\)80029-4](https://doi.org/10.1016/S0047-2484(85)80029-4)
- Faure, G. & Mensing, T. M. 2005. *Isotopes: principles and applications*. 3. ed. Hoboken: John Wiley & Sons.

- Fjellström, M. et al. 2019. Food and cultural traits in coastal Northern Finnmark in the 14th – 19th centuries. *Norwegian Archaeological Review* 52(1): 20–40. <https://doi.org/10.1080/00293652.2019.1621366>
- Fjellström, M. et al. 2020. Approaching historic reindeer herding in Northern Sweden by stable isotope analysis. *Journal of Nordic Archaeological Science* 19: 63–75.
- Fjellström, M. et al. 2021. Food, mobility, and health in a 17th and 18th Century Arctic Mining Population in Silbojokk, Swedish Sápmi. *Arctic* 74(2): 206–226. <https://doi.org/10.14430/arctic72709>
- Fjellström, M. et al. 2022. Mobility in early reindeer herding. In: A.K. Salmi (ed.) *Domestication in action*. Arctic Encounters. Cham: Springer. [https://doi.org/10.1007/978-3-030-98643-8\\_7](https://doi.org/10.1007/978-3-030-98643-8_7)
- Fjellström, M. et al. Accepted. Reindeer retrieved from melting snow patches reveal information on prehistoric landscape use in Swedish Sápmi. *Rangifer*.
- Glykou, A. et al. 2018. Intra- and inter-tooth variation in strontium isotope ratios from prehistoric seals by laser ablation multi-collector inductively coupled plasma mass spectrometry. *Rapid Communications in Mass Spectrometry* 32(15): 1215–1224. <https://doi.org/10.1002/rcm.8158>
- Hansen, L.I. 1990. *Handel i Nord. Samiske samfunnsendringer ca. 1550 – ca. 1700*. Ph.D. thesis Tromsø University.
- Hedman, S.-D. 2003. *Boplatser och offerplatser. Ekonomisk strategi och boplatsemönster bland skogssamer 700–1600 AD*. Umeå: Umeå University.
- . 2015. Ställotomter från kusten och upp till hög fjällen, vad berättar de?. In: B. Evjen & M. Myrvoll (eds) *Från kust til kyst. Åbpegåttest åbpegåddáj. Moter, miljø og migrasjon i pitesamisk områden*. Stamsund: Orkana Akademisk, 29–50.
- Hedman, S.D. & Olsen, B. 2009. Transition and order: a study of sámi rectangular hearths in Pasvik, Arctic Norway. *Fennoscandia Archaeologica* XXVI: 3–22.
- Kaufman, D. S. et al. 2009. Recent warming reverses long-term arctic cooling. *Science* 325: 1236–1239. <https://doi.org/10.1126/science.1173983>
- Kjellström, R. 1983. *Lappmarksmikroskop: intensivinventering av kulturlämningar i Jokkmokksfjällen*. Stockholm: Nordiska museet.
- Krouse, H.R. 1980. Sulphur isotopes in our environment. In: P. Fritz & J. Ch. Fontes (eds) *Handbook of environmental geochemistry Vol. 1 The terrestrial environment* A. Amsterdam: Elsevier, 435–471.
- Larsson, L. 1994. The earliest settlement in southern Sweden. Late Paleolithic settlement remains at Finjasjön in the north of Scania. *Current Swedish Archaeology* 2: 159–177. <https://doi.org/10.37718/CSA.1994.09>
- Liedgren, L. 2003a. *Utgrävningar av härdar och stalotomter i Adamvaltaområdet, Arjeplog, Lappland, 2001*. Silvermuseet, rapport 31.
- . 2003b. *Utgrävningar av stalotomter i Adamvaltaområdet, Arjeplog, Lappland, 2002*. Silvermuseet, rapport 35.
- . 2004. *Utgrävningar av härdar och stalotomter i Adamvaltaområdet, Arjeplog, Lappland 2003*. Silvermuseet, rapport 37.
- Liedgren, L. et al. 2007. Radiocarbon dating of prehistoric hearths in alpine northern Sweden: problems and possibilities. *Journal of Archaeological Science* 34: 1276–1288. <http://dx.doi.org/10.1016/j.jas.2006.10.018>
- Liedgren, L. & Bergman, I. 2009. Aspects of the construction of prehistoric Stållo-Foundations and Stållo-Buildings. *Acta Borealia* 26(1): 3–26. <https://doi.org/10.1080/08003830902951516>

- Liedgren, L. et al. 2016. Hearths in the coastal areas of northernmost Sweden, from the period AD 800 to 1950. *Rangifer* 36(1): 25–50. <https://doi.org/10.7557/2.36.1.3767>
- Mebius, H. 2003. *Bissie. Studier i samisk religionshistoria*. Östersund: Jengel.
- Minagawa, M. & Wada, E. 1984. Stepwise enrichment of  $^{15}\text{N}$  along food chains: further evidence and the relation between  $\delta^{15}\text{N}$  and animal age. *Geochemica et Cosmochemica Acta* 48: 1135–1140. [https://doi.org/10.1016/0016-7037\(84\)90204-7](https://doi.org/10.1016/0016-7037(84)90204-7)
- Mulk, I.-M. 1994. *Sirkas – ett samiskt fångst-sambälle i förändring Kr. f. – 1600 e.Kr.* Dissertation. Studia archaeologica universitatis umensis 6.
- Nehlich, O. 2015. The application of sulphur isotope analysis in archaeological research: a review. *Earth-Science Reviews* 142: 1–17. <https://doi.org/10.1016/j.earscirev.2014.12.002>
- Nehlich, O. & Richards, M.P. 2009. Establishing collagen quality criteria for sulphur isotope analysis of archaeological bone collagen. *Archaeological and Anthropological Sciences* 1: 59–75. <http://dx.doi.org/10.1007/s12520-009-0003-6>
- Nieminen, M. & Pietilä, U. 1999. *Peurasta poroksi (from wild to semi domesticated reindeer)*. Rovaniemi: Paliskuntain yhdistys.
- O'Connell, T.C. & Hedges, R.E.M. 1999. Isotopic comparison of hair and bone: Archaeological analyses. *Journal of Archaeological Science* 26: 661–665. <https://doi.org/10.1006/jasc.1998.0383>
- Olsen, L. 2010. *Sørsamisk historie i nytt lys*. Senter for samiska studier, Tromsø University.
- Parker, K.L. et al. 2005. Protein conservation in female caribou (Rangifer tarandus): effects of decreasing diet quality during winter. *Journal of Mammals* 86(3): 610–622. [https://doi.org/10.1644/1545-1542\(2005\)86\[610:PCIFCR\]2.0.CO;2](https://doi.org/10.1644/1545-1542(2005)86[610:PCIFCR]2.0.CO;2)
- Richards, M.P. et al. 2003. Sulphur isotopes in palaeodietary studies: a review and results from a controlled feeding experiment. *International Journal of Osteoarchaeology* 13: 37–45. <https://doi.org/10.1002/oa.654>
- Routier, S. 2009. *Managing reindeer lichen during forest regeneration procedures: linking Sámi Herders' knowledge and forestry*. Umeå: Department of Forest Ecology and Management, Swedish University of Agricultural Sciences.
- Ryd, Y. 2014. Wild reindeer and Sami hunting with bow and arrow. *Journal of Glacial Archaeology* 1: 11–24. <https://doi.org/10.1558/jga.v1i1.11>
- Salmi, A.-K. et al. 2015. Animal offerings at the Sámi offering site of Unna Saiva – Changing religious practices and human–animal relationships. *Journal of Anthropological Archaeology* 40: 10–22. <https://doi.org/10.1016/j.jaa.2015.05.003>
- Salmi, A.-K. et al. 2020. Zooarchaeological and stable isotope evidence of Sámi reindeer offerings. *Journal of Archaeological Science: Reports* 29. <https://doi.org/10.1016/j.jasrep.2019.102129>
- Sealy, J. 2001. Body tissue chemistry and paleodiet. In: D.R. Brothwell & A.M. Pollard (eds) *Handbook of archaeological sciences*. New-York: John Wiley & sons, 269–279.
- Serning, I. 1956. *Lapska offerplatsfynd från järnålder och medeltid i de svenska lappmarkerna*. Dissertation. Almqvist & Wiksell. Stockholm.
- Sommerseth, I. 2009. *Villreinfangst of tamreindrift i indre Troms. Belyst ved samiske boplasser mellom 650 og 1923*. Dissertation. Institutt for arkeologi og sosialantropologi, Tromsø University.

- . 2011. Archaeology and the debate on the transition from reindeer hunting to pastoralism. *Rangifer* 31(1): 111–127.
- . 2021. Den samiske bjørnekulten: arkeologiske spor til samisk historie og religion. *META-Hisotriskarkeologisk tidskrift* 2021: 9–30.
- Storli, I. 1994. “Stallo”-boplassene. *Spor etter de første fjellsamer?* Instituttet for sammenlignende kulturforskning. Serie B, skrifter XC. Oslo: Novus forlag.
- van Klinken, G.J. 1999. Bone collagen quality indicator for paleodietary and radio-carbon measurements. *Journal of Archaeological Science* 26(6): 687–695.
- Van Riel, S. 2017. Viking age combs local products or objects of trade? *Lund Archaeological Review* 23: 163–178.
- Wadleigh, M.A. et al. 1994. Sulphur isotope tests of sea salt correction factors in precipitation: Nova Scotia, Canada. *Water, Air and Soil Pollution* 77(1): 1–16. <https://doi.org/10.1007/BF00483047>
- Webb, C., et al. 2017. Sulphur-isotope composition of pig tissues from a controlled feeding study. *STAR: Science & Technology of Archaeological Research* 3(1): 71–79. <https://doi.org/10.1080/20548923.2017.1368821>

# 11

## HOUSE TO HOUSE – FRAGMENTATION AND DECEPTIVE MEMORY-MAKING AT AN EARLY MODERN SWEDISH COUNTRY HOUSE

*Anna Röst*

### Opening a deceptive door: memory-making and heritage construction through fragments

The two wooden houses, called the wings, which stand on each side of the court, are originally of very old date (...) that on the right, however remains in its ancient state. I have been in it with Tante Fredrika to see the handsome old carved wood-work of the doors. (...) The tradition is, that the great champion of Protestantism, Gustavus Adolphus, passed a night in this very house before setting out on his great expedition to Germany.

*(Howitt 1866:221–222)*

Margaret Howitt describes a visit to the famous author and feminist Fredrika Bremer at Årsta manor in 1864. Several visitors to Årsta in the 19th century reproduced the story of seeing the elaborately carved early 17th-century doors of the Årsta manor wing and hearing of the visit of the king Gustavus Adolphus in 1621, mustering his troops at Årsta for war.

However, there is a problem with this story. On the first depiction of the current Årsta manor from 1667 (Figure 11.1), there is no wing building. None had, as far as we know, been built yet (this issue is further explored below). The history of the carved door and the king's visit is thus most likely a different one than the visitors were told. They did not step inside the king's house. The deception of the doors at Årsta – fragments of a previous building – is but one of several categories of fragments invoking 'pastness' throughout the history of the estate. As we shall see, fragments of previous buildings and other material culture referring to a glorious past are not only reused but invented and falsified over the centuries.

The focus of the research project *Årsta in Österhaninge – Manor House history and Nobility Culture 1550–1703*<sup>1</sup> is to analyse the transformations in material culture in an Early Modern high-status context. More specifically, the research questions aim at clarifying the circumstances surrounding the abandonment of “Old Årsta” (a medieval manor house, now an archaeological site) and the building (c. 1660) of the current manor. Furthermore, the project aims to discuss the material culture of Årsta and its transformations and trajectories during a turbulent time in Swedish history and a transformative phase in the culture and ideology of the Swedish nobility. When unlocking the archaeological and archival records, it has become clear that a crucial aspect of understanding is that of memory through objects and a sometimes deceptive historiography.

The aim of this chapter is to present one example of the usefulness of fragmentation theory in an Early Modern (i.e. historical) archaeological context and its implications for interpretations of past attitudes towards place and the continuous production of the heritage of that place over centuries. The notion of ‘place’ can obviously, like ‘fragment’, be perceived as a wide, all-encompassing concept. However, it has been extensively discussed within the humanities and is perceived in this study a socially construed, organised space where identity is created and upheld (rather than merely a locale where certain events happen) (cf. Smith 2006:74–80 for an overview of ‘place’ as a heritage concept). Further useful concepts to pin down what is at stake when discussing strategies in heritage production in a certain place are ‘place value’ and ‘time-mark’. John Chapman has elaborated on these, stating that “a time mark is an event of cultural significance that occurred at or in association with a place and that helped create or reinforce the place value of that place” (Chapman 2012:73).

Through applying the fragment as a conceptual tool and category, aspects of past strategies that are not necessarily visible through archives or architectural or art historical analyses are brought to light and discussed. Different categories of materials (i.e. architectural features, building materials, and artefacts) that are usually studied separately may, as fragments *per se* be studied as part of a social strategy of remembrance and identity. The doors at Årsta manor were not broken into fragments. They were fragments in the sense of parts of a lost whole, reused, and thus a tool for inscribing meaning to a new whole. Reuse of architectural elements and objects, incorporating them into new contexts, is of course a feature of a great many, if not all, times and places in the past and present (e.g. Olivier 2011:129–132 for a discussion of archaeological ‘palimpsests and memory objects’). However, it may well be of interest to keep exploring the variety of contexts where place identity and value are construed through the use of fragments of the past. Triangulating, as historical archaeology allows – fragmentation theory with multiple sources from archaeology, archives, and historiography can shed

new light on the places archaeologists study. Through the example of the reused doors and other fragment usage that was to follow at Årsta, I aim to show that there was a need to objectify the time-mark of Gustavus Adolphus' visit and the lineage of the then owner family of the estate to add place value to Årsta.

The example given in this chapter is of a theoretical, exploratory, and tentative nature, as the Årsta research project is ongoing. Further details in connection with the buildings at Årsta will hopefully come to light in due course. The case file is thus open for discussion. Let's hear the evidence and the witness statements.

### Årsta manor: the scene

Årsta manor is located 25 km south of Stockholm, Sweden. Approximately 800 m north of the current manor house and park is the protected ancient monument "Old Årsta" (Ancient monument no: RAÄ Österhaninge 39:1/L2014:3474), which today consists of three visible building foundations surrounding a courtyard with a well. The earliest image of the current manor, a pencil drawing dated to 1667 (Figure 11.1), shows the buildings of Old Årsta to the right (indicated by the words "Gambla Herrgårdén" ["the old manor"]).

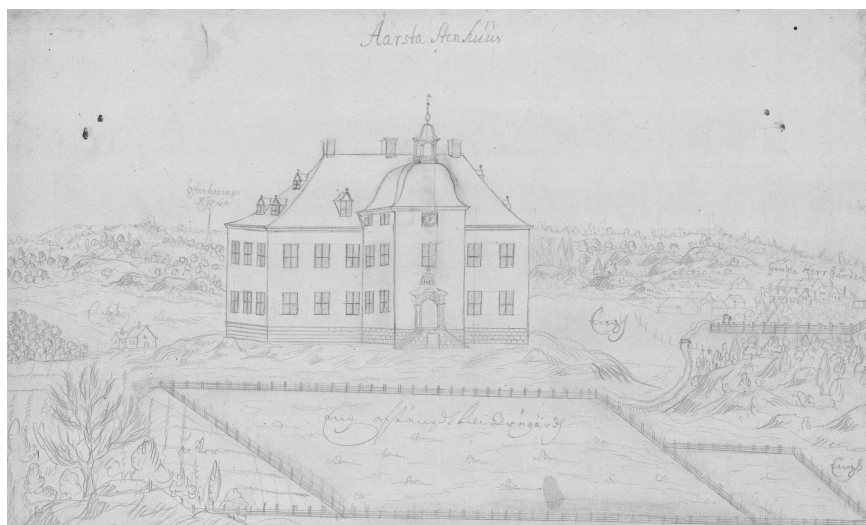

**FIGURE 11.1** Årsta in 1667. Pencil drawing by Henrik Haij. (National Library of Sweden, CC0 1.0). The manor house exterior has not changed and appears very much the same today. Note the buildings in the background to the right: Old Årsta as it appeared a few years before its destruction.

The excavations at Old Årsta in the 1920s, 2005, 2011, and 2012 have established that the site is that of a manor house with several building phases. Dated finds and <sup>14</sup>C-analyses suggest the site's establishment at the latest in the 1300s. The medieval finds and structures, however, remain sparse and elusive, as the main find categories recovered so far are high-status ceramics, glass, and other finds from the 16th and 17th centuries. Heavy charcoal layers and building debris suggest an extensive fire during the last decades of the 1600s (excavation reports, see Salvén 1923; Carlsson 2005; Beronius Jörpeland et al. 2017).

The current Årsta manor was most likely commissioned by Baroness Barbro Åkesdotter Natt och Dag, wife of Admiral Clas Bielkenstierna (Bedoire 2002). Details of the circumstances surrounding the building of the new manor are not yet known. No archival records discovered to date have revealed the name of the architect, and no records of building costs, etc. remain in the Årsta estate archive in the Swedish National Archives. However, dendrochronological samples (Daly 2022) suggest that the roof was constructed around 1660, supporting earlier research estimates (Redelius 1992:12–19; Bedoire 2002:201–207). The drawing from 1667 (Figure 11.1) seems to depict a recent building where no park is yet established (in front of the building is the following note: “meadow closed off for garden”, Swe. “Eng afstängd till trädgårdh”). Worth noting is that the newly built manor in 1667 stands alone; no wings or outbuildings have yet been constructed.

### **Cum Deo et Victricibus Armis: the event**

“With God and Victorious Weapons” was the motto of Swedish king Gustavus Adolphus (1594–1632). When he was killed in the battle at Lützen during the Thirty Years War, it was the end of a lifetime of extraordinary military victories. The memory of the warrior king was treasured for generations, as he was rendered the instigator of Sweden’s “Age of Greatness”, an era of geographical and cultural expansion lasting until 1718.

At Årsta manor, the owners had a relatively close connection to the royal household during Gustavus Adolphus’ reign. In 1621, the king set sail with a heavily armed fleet to (successfully) besiege Riga in the second Polish war against his cousin Sigismund, a competitor to the Swedish throne. The mustering of the soldiers took place in the meadows at Årsta in July. Before boarding the ships at a nearby port, Gustavus Adolphus and the Royal family stayed at Årsta manor, and the King’s right-hand man, the great statesman Axel Oxenstierna, read out the King’s new War Articles to the troops (Starbäck & Bäckström 1885–86:81). It was clearly a moment of significance.

The reign of Gustavus Adolphus was a time of increasing material commemoration of royal events and victories. (The first museum in Sweden, The

Royal Armoury, was founded by the king in 1627.) At Årsta, Lady Elisabeth Gyllenstierna commissioned a set of expensive pews and a pulpit for the parish church (Figure 11.2a), most likely to mark the occasion of 1621 and prepare for further royal visits (Redelius 1992:21–22). In the inlays of the elaborate woodwork are the initials EG (Elisabeth Gyllenstierna) and HKS (Hans Klasson, her husband), and the years 1621, 1622, and 1623. It is hardly farfetched to assume that the manor house at (Old) Årsta was also refurbished to suit royal guests. The door, through which Fredrika Bremer's visitor would walk at (New) Årsta some 240 years later, is an obvious example of the same style of late Renaissance woodwork, presumably even from the same workshop (Figure 11.2).



**FIGURE 11.2** (a) The Årsta pews, still in Österhaninge parish church. Photo: Ivar Schnell. (b) The door from Årsta Manor, dated to around 1620. Photo: Nordiska museets fotoateljé. (Nordiska museet CC BY-NC-ND 2.5).

## Remains

At Old Årsta, the ground around the medieval/early modern building foundations is still saturated with debris, emerging around fallen trees and animal nests. Shattered bricks, glass sherds, and stonework, as well as weed-covered mounds of earth left by brief archaeological projects, leave the present-day visitor somewhat bewildered. The impression is of untidiness, fragmentation, and abandonment. There is, however, a distinction between abandonment, disinterest, and oblivion. After the fire in the late 1600s and after the Bielkenstiernas had built their new manor in the middle of the same century, Old Årsta remained in memory and in physical form, even if in a fragmented state. Meaning applied to the material remains of Old Årsta on site, and those fragments dispersed and used elsewhere were assigned different trajectories, as we shall see.

It is possible to get a glimpse of what was lost and kept in the transitions (fire and relocation) from Old Årsta to the newly built manor. Archaeological excavations at Old Årsta have shown that the pencil drawing (Figure 11.1) depicts with a decent degree of accuracy what the artist Henrik Haij actually saw in 1667, rather than just stereotyped random buildings inserted as a backdrop (Carlsson 2005; Beronius Jörpeland et al. 2017). Buildings with multiple storeys and chimneys were placed in an L-shape, surrounding a courtyard. In the foreground are simpler (farm?) buildings. An interesting point made in the archaeological report is that although it is evident that the dwelling houses had brick walls, there are very few intact bricks left on site (Carlsson 2005:25). This is not an uncommon circumstance when excavating medieval buildings, as bricks were expensive and the production of them was time-consuming (Monié Nordin 2021:116–117). Only the granite foundations at Old Årsta remain untouched.

There are no known written records of how later inhabitants of Årsta related to the site of Old Årsta. A brief note in Margaret Howitt's relation of her year with Fredrika Bremer in 1864 simply states that their carriage passes "a rocky paddock where old fruit and other trees grew; she told me that the first Årsta had stood there" (Howitt 1866:202). However, among the finds from the excavations are coins dating from the reigns of Fredrik I (1720–1751), Adolf Fredrik (1751–1771), and Gustav IV Adolf (1792–1809) (Beronius Jörpeland et al. 2017). It appears that it was a site to visit once in a while, but the story of Old Årsta as a significant place seems to have fragmented along with its buildings.

## House to house

The exterior of the current manor at Årsta remains today as it was when the building was new in the 1660s (Figure 11.1). The coats of arms of

Bielkenstierna and Natt och Dag above the portal speak clearly of the ideology of the time, the importance of lineages combined, and ambitions for the future. Architecturally, though, the building was conservatively designed (Bedoire 2002:200–203), mirroring manors built in previous decades. Historian Anne Laurence has discussed the fact that buildings commissioned by women in England in the 17th century were more likely to be built conservatively. She suggests that the stylistic choices are partly due to a wish for commemoration of women's families and inheritance, referencing an ancient past (Laurence 2003:301–303). Those aspects can certainly be said to be at play in the staging of the Årsta family by Barbro Åkesdotter Natt och Dag, but in the material culture, a very strong wish to highlight a new and glorious bloodline is also present. Apart from the manor house, Barbro commissioned a grand marble memorial by sculptor Nicholas Millich for the parish church (Stenqvist & Furuland 2011:28). Its Latin inscription speaks of the grief after Barbro's only surviving adult son (there had been five sons; four had died very young) had been lost on the sinking warship *Svärdet* at the battle of Öland in 1676 (Swedish National Archives, Årstasamlingen, Saxenbergssonationen).

Besides building conservatively, fragments of family and place history were certainly kept in the relocation from Old Årsta to the new (but old-looking) building. It appears as though choices were made as to what was suitable for reuse and what aspects of the family were deemed best to highlight. Among the materials and objects that were relocated, there are interesting differences in placement and usage. One reasonable and practical example is the lack of intact bricks at Old Årsta. It is hardly farfetched to assume that the builders of the new Årsta used the material readily available to them, thus incorporating the old into the new. Gathering suitable building materials for a new building appears uncontroversial and economical. Dendrochronological analyses of roof timbers at new Årsta also indicate that a pine rafter may have been felled as early as 1583–84 (Daly 2022:2), thus indicating a possible reuse. In the estate inventory of Barbro Åkesdotter Natt och Dag, dating to 1664 (Swedish National Archives, Årstasamlingen, E6106), a number of items are listed as “old”, including paintings, silverware, and bed linen. It is reasonable to assume that household goods deemed suitable for the new manor were relocated and stayed in continuous use. The household at the new Årsta would have been permeated with family history, built into the walls and roof, and in everyday items handled and in view.

Practical considerations aside, objects, materials, and fragments belonging to the past could also be assigned trajectories, imbuing them with additional and changed meaning. In the early 1800s, the Bremer family moved into Årsta manor and started an extensive interior refurbishment. The house had not been altered and had not been inhabited for a hundred years. Knocking down an interior wall, they found a crossbow interred in the structure, dated to the 16th or 17th centuries (Nordiska museet, nv. no NM.0061423).

Interestingly (but somewhat outside the scope of this text), a chest in the attic was found to contain the torn and blood-stained clothes of Clas Bielkenstierna, worn when he was wounded in a naval battle in 1659. Being the source of much discomfort and ghost apparitions amongst those servants having to run errands to the attic, the chest was removed to the parish church (Bremer 1912:42). The crossbow, whose meaning was lost to the Bremers, remained a curiosity at Årsta until it was donated to Nordiska museet (Inv. no NM.0061423).

So what about the deception of the door – a fragment of a building that came to carry an important story? During the 18th and 19th centuries, there were two timber wing buildings at Årsta manor (as shown in the inventory of Sigrid Fleming, 1782, National Archives). Inside one of them was an elaborately decorated Renaissance door (Figure 11.2b). The door undoubtedly belongs to the time of the visits of Gustavus Adolphus. The building, which was torn down in the 1860s, apparently did not. Even though it is described by visitors on separate occasions in that same decade as being “old and worn” or even “ancient” (Howitt 1866; Upmark 1977 [1864]), it is reasonable to assume that this is an opinion relating to its general appearance rather than factual knowledge. According to the high-status finds of glass and ceramics at Old Årsta, the main dwelling house would have been there in the first half of the 1600s. The absence of a wing building in the pencil drawing from 1667 further strengthens this picture. I assume that, like building materials and household goods, the elaborate woodwork was salvaged in the transition, and reused in a wing building that came into being in the late 1600s. Wings are depicted in *Suecia Antiqua et Hodierna*, first printed in 1716 (Dahlbergh 1910 [1715]).

In the 1860s, the old wing was torn down by the owners of Årsta at that time, the Saxenberg family. It appears to have been worn down to a point beyond repair and was replaced by a new, one-storey plastered building. The elaborate door, together with the crossbow found by the Bremers and some pieces of gilt leather tapestries, were donated to Nordiska museet by the Saxenbergs in 1890 (Inv. No 61422, 0266939). The story of the king could thus have returned to being an oral-textual story, with no material authenticity remaining at Årsta from the events of 1621 and 1630 and no building for the king. But once again, it did not.

A hundred metres from the manor house and the wings sits an ancient-looking red timber building. It is a two-storey storehouse, stylistically appearing to be from the early 1800s. It is not dated. In front of its doorways is a threshold made of an elaborately carved stone slab, quite out of place at a common farm building (Figure 11.3). Today, this building is known as “The Mustering Barn” (Swe. *Mönstringsladan*). A sign on its wall, as well as the most recent publication on the history of Årsta, states that this was the building where Gustavus Adolphus most likely mustered his troops in

1621 (Stenqvist & Furuland 2011:14). It is not possible to say when this “tradition” started, but the author Stenqvist grew up at Årsta and must have heard it at the latest in the mid-20th century. It is not recorded in any archival records discovered to date. Conveniently, after the “King’s wing” was



**FIGURE 11.3** Fragments exposing and imposing deception. An elaborate stone slab used as a threshold for the “Mustering Barn”. It is most likely reused from a previous building, possibly the torn-down wing attributed to the King’s visit (photo: Anna Röst).

demolished, a new house for the king was discovered. Once again, pastness is invoked through a fragment indicating a high-status building, and the material memory of the king passed from house to house.

The fondness for using fragments of past dramatic events implying authenticity of place at Årsta continued into the 20th century. The manor house was renovated in the 1910s, and in the Årsta chapter in *Svenska slott och herresäten* (Eng. Swedish Castles and manors) the reader is made aware that the bookshelves in the billiard room are made of the sea-drenched oak timbers of the unfortunate ship *Svärdet*, which sank with the son of the house Axel Bielkenstierna in 1676 (Svensson 1934:111; see also Arnshav this volume). Once again, this is a deception on the part of the owners. Anyone familiar with sea-drenched oak can see that this is not it. The wreck of *Svärdet* was discovered in 2011 (Hansson 2017).

### The evidence exposed

At Årsta manor today, there is a museum dedicated to showing and telling the visitors about “a manor of many stories” (its marketing tag line). To make the stories understandable, interesting, and attractive, the element of authenticity through materiality and fragments is just as strategically used as by previous owners of Årsta throughout the centuries, although not in a similarly deceptive way. Certain stories are exposed and told at certain places at the manor. The grand staircase at new Årsta is the work of Barbro Åkesdotter Natt och Dag. The upstairs rooms are the home of world-famous feminist Fredrika Bremer. “The Mustering Barn” remains “the mustering barn”, the story of Gustavus Adolphus is told with a wink in the eye and a “traditionally it has been alleged that...”.

Examining the use of fragments through the centuries at Årsta, it becomes apparent that the need for evoking pastness using fragments appears to be continuous, but its purpose and strategies change over time and according to context. When the transition from Old Årsta to the new manor took place in the mid-1600s, it was a time for materially manifesting lineage and power relations. The nobility was in a political tug of war and simultaneously in symbiotic negotiation with the post-Gustavus Adolphus crown for the rudder of the expanding state (Bedoire 2001:103–109, 145–149). At Årsta, the usage of material culture looks to the past and the future, with an emphasis on individuals from the owner families: Natt och Dag and Bielkenstierna. Practical concerns may have prompted the reuse of building materials, yet the household members were surrounded by old family objects. They proceeded through new monuments by displaying coats of arms, commissioning portraits, and collecting heroic, yet fragmented, memorabilia (such as the blood-stained, torn clothes of Admiral Bielkenstierna).

In the 1800s, the story of Gustavus Adolphus' visits was renewed at Årsta, and moved to the forefront of the estate's storytelling. By then, 200 years had passed since the event. It was no longer within living memory and was thus open to interpretation and manipulation. In this context, it is not at all surprising that this is the time for elevating the story of the king and attributing a building to his visit based on a fragment – an old door. The 1800s were a time of historical romanticism as part of the nation-building process. Many of the heroes of the “Age of Greatness” were attributed extraordinary traits. Thitherto untold details of dramatic events surfaced through inventive historians and became part of a national grand narrative (for instance, see Eriksson 2017:42–47 for an illustrative example concerning the alleged heroism of Admiral Claes Uggla, commander of the unfortunate *Svärdet*). Attempts to pin down royal visits on one's map were a pastime for many local patriots around the country. The result of these efforts is that even today, a great number of buildings dating to the 18th century or even later are confidently presented as “Queen Christina's hunting lodge”. Her reign ended in 1654, and she would have spent all her days and nights hunting across the country to make these stories true.

### **Building a case for fragmentation theory in historical archaeology**

The intentional or unintentional breakage of objects and the post-breakage state and usage of fragments have been stressed numerous times in fragmentation theory. So has the possible mapping of the trajectory of the fragment and its future meanings beyond its origins. (Chapman 2000; Chapman & Gaydar-ska 2007). As we have seen above through the examples from Årsta, it was important to keep certain material cultures and to create something new out of them by displaying (deceptive) authenticity through these fragments of the past. This continued at the estate from the mid-1600s into the 1900s, always relating to a certain royal connection. The common ground throughout the centuries starts with the little word “old”, found in the knowledge of reused materials and in the inventory of Barbro Åkesdotter. It was crucial in the 19th-century description of the displaced Renaissance door in the wing and later in the threshold of “the Mustering Barn”. Furthermore, the fragmented, timeless, and displaced state of the “old” objects left them open to changing interpretations and inscriptions while invoking a sense of authenticity (*cf.* Burström 2013). As Laurajane Smith points out, “...the physicality of heritage provides a sense of the immutability of value and meaning; these are never fixed but always subject to negotiation and change” (Smith 2006:75).

Returning to the concepts of ‘time mark’ and ‘place value’, I thus suggest that the fragments *per se* at Årsta became tools for adding place value,

situating its interpreters and those who are told the interpretations in a specific historical context and in relation to its past and present. I argue that the exploratory survey of fragment usage at Årsta – where meaning is transformed or recreated over time – reveals an example to which the concept of fragmentation in historical archaeology can be applied as a potential tool for exploring the continuous change of inscribed meaning. Fragments were, in this case, used to suit each contemporary notion of what history and heritage should be.

Mats Burström has argued that fragments in a modern present-day context – being an anomaly in a general framework – have the power to make us notice and reflect on aspects of the past other than the most obvious ones (Burström 2013:319). I find this notion to be both true and thought-provoking, as the example of fragments at Årsta seems to do just this. But the fragment usage through the estate history actually intended the opposite. The purpose of fragment usage at Årsta was to support and reinforce the grand narratives of the 1600s and 1800s, respectively. It imposed pastness and placed the estate in the great scheme of things. An (old and worn, hopefully soon fragmented) cliché in regard to historical archaeology is that such endeavours are expensive ways of confirming what historians already know (Andrén 1997:185). Paradoxically, in the example presented above, material fragments of history have historically been used to reinforce grand narratives. Simultaneously, in doing just that, they carry the potential of revealing new angles of people's relations to place, objects, heritage, and social positioning, besides the desire for a good story. The toolbox of historical archaeology, with its potential for triangulating – always starting with material culture but tapping into textual sources, art history, and historiography – thereby enables an extended reflection of what (fragmented) material culture does and how it can be used. At Årsta, it gives us a glimpse of the (deceptive) past in the past.

### Archival records

Swedish National Archives (Riksarkivet):

Årstasamlingen, E6106.

Årstasamlingen, Saxenbergdonationen

Svea Hovrätt, Adliga bouppteckningar, Sigrid Fleming 1782.

National Library of Sweden (Kungliga biblioteket):

Daniel Tilas, Sockne-skrifwaren, (1750's) Handskrift M25.

National Heritage Board's Archives (Antikvarisk-topografiska arkivet):

Carlsson, C, 2005. Forskningsundersökning vid Årsta gamla gård, RAÄ 39, Österhaninge socken, Södermanland. Syddansk Universitet. 321-3905-2005.

Salvén, E. 1923. Rapport till Riksantikvarien, angående Årsta gamla gård. 2140-1923.

## Note

- 1 Swe. Årsta i Österhaninge, herrgårdshistoria och adelskultur ca. 1550–1703. The project is funded by Brandförsäkringsverkets stiftelse för bebyggelsehistorisk forskning.

## References

- Andrén, A. 1997. *Mellan ting och text. En introduktion till de historiska arkeologierna*. Stockholm: Brutus Östlunds Bokförlag Symposium.
- Bedoire, F. 2002. *Guldålder. Slott och politik i 1600-talets Sverige*. Stockholm: Albert Bonniers förlag.
- Beronius Jörpeland, L. et al. 2017. *Forskningsundersökningar vid Årsta gamla gård åren 2011 och 2012*. Stockholm: Arkeologerna, Statens historiska museer.
- Bremer, C. 1912. *Fredrika Bremer. Själfbiografiska anteckningar och brefjämte en teckning af hennes lefnad och personlighet*. Stockholm: Beijers bokförlagsaktiebolag.
- Burström, M. 2013. Fragments as something more. Archaeological experience and reflection. In: A. Gonzalez Ruibal (ed.) *Reclaiming archaeology: beyond the tropes of modernity*. London: Routledge, 311–322.
- Chapman, J. 2000. *Fragmentation in archaeology: people, places and broken objects in the prehistory of South Eastern Europe*. London: Routledge. <https://doi.org/10.4324/9780203759431>
- . 2012. The negotiation of place value in the landscape. In: J.K. Papadopoulos & G. Urton (eds) *The construction of value in the ancient world*. Los Angeles: Cotsen Institute of Archaeology Press, University of California, 66–99. <https://doi.org/10.2307/j.ctvdjrrxf.8>
- Chapman, J. & Gaydarska, B. 2007. *Parts and wholes: fragmentation in prehistoric context*. Oxford: Oxbow.
- Dahlbergh, E. 1910 (1715). *Suecia Antiqua et Hodierna*. Stockholm: Fröleen & Comp.
- Daly, A. 2022. *Dendrochronological analysis of timbers in Årsta slott, Stockholm. dendro.dk report 2022:1*. Copenhagen.
- Eriksson, N. 2017. *Riksäpplet. Arkeologiska perspektiv på ett bortglömt regalskepp*. Lund: Nordic Academic Press.
- Hansson, J. 2017. *Vård och skyddsplan för fartygslämning identifierad som Svärdet utanför svenskt territorium, inom svensk ekonomisk zon*. Stockholm: Sjöhistoriska museet.
- Howitt, M. 1866. *Twelve months with Fredrika Bremer in Sweden*. London: Jackson, Walford and Hodder.
- Laurence, A. 2003. Women using building in seventeenth-century England: a question of sources. *Transactions of the Royal Historical Society* 13: 293–303. <https://doi.org/10.1017/S0080440103000161>
- Monié Nordin, J. 2021. *Mellan medeltid och modernitet*. Lund: Studentlitteratur.
- Olivier, L. 2011. *The dark abyss of time. Archaeology and memory*. London: Altamira Press.
- Redelius, G. 1992. Årsta i Österhaninge. Haninge: Bildstens förlag.
- Röst, A. (in prep.) *Tillbaka till Gamla Årsta – återbesök, tolkning och analys av de arkeologiska undersökningarna*.
- Smith, L. 2006. *Uses of Heritage*. London: Routledge.

- Starbäck, C.G. & Bäckström, P.O. 1885. *Berättelser ur svenska historien. Fjerde bandet*. Stockholm: Beijer.
- Stenqvist, G. & Furuland, G. 2011. Årsta slott – en kulturskatt i Haninge. Stockholm: Årstasällskapet för Fredrika Bremer-studier.
- Svensson, G. 1934. Årsta, Österhaninge socken, Stockholms län. In: A. Roosval (ed) *Svenska slott och herresäten. Band II*. Stockholm: Natur & Kultur, 99–128.
- Upmark, G. 1977 (1864). *Fornlemningar i Sotholms Härad*. Västerhaninge: Haninge hembygds-gille.

## **PART III**

# Fragmentation and the manipulation of objects



Taylor & Francis

Taylor & Francis Group

<http://taylorandfrancis.com>

# 12

## MULTIPLE OBJECTS

### Fragmentation and process in the Neolithic of Britain and Ireland

*Andrew Meirion Jones*

#### **Introduction**

My aim in this paper is not to discuss fragmented objects but to reflect on how John Chapman and Bisserka Gaydarska's discussion of practices of fragmentation relate to wider social and material processes in prehistory. I will consider the impact of Chapman's (2000) discussion of the concept of fragmentation in the prehistory of the Balkans and his work with Gaydarska (Chapman & Gaydarska 2007) and how this work might be fruitfully extended into an analysis of things as multiplicities, or 'multiple objects', in the prehistoric past.

Rather than focusing on fragmentation as a stand-alone practice, I want to emphasise Chapman's discussion of the processes of enchainment and accumulation. Enchainment occurs as objects, such as pottery, are fragmented and dispersed. Fragments of objects "transmit not only the symbolism of their complete, once-intact form but also the enchainment, or fractal, connotations of past makers and owners" (Chapman 2000:39). Conversely, we also find evidence for the accumulation of objects, particularly metalwork. The use of complete objects in local enchainment relations symbolised social integration, and the deposition of locally produced complete artefacts would signify a place or time in which it was important to emphasise integration (Chapman 2000:45). We can consider enchainment – the links between people that are facilitated by objects – as underpinning the twin practices of breaking things (fragmentation) and grouping things together (accumulation).

The interlinked character of the practices of fragmentation and accumulation also alerts us to a significant, and possibly underplayed, aspect of Chapman and Gaydarska's work: it was concerned less with specific social or

material practices (fragmentation and accumulation) and more with mapping a sense of social and material process; this is something that Clive Gamble (2007) recognised when he used these concepts to dismantle and rework long-held assumptions concerning revolutions in human behaviour from the Palaeolithic onwards. The importance of process has more recently been discussed by Chris Gosden and Lambros Malafouris (2015) in an overarching analysis of what they call Process-Archaeology. They begin their analysis of process with a series of fundamentals: firstly, that reality is best understood in terms of modes of becoming, and secondly, that everything in the universe is in motion. According to Gosden and Malafouris (2015:703) “there is no such thing as inert, timeless.... or formless matter”.

Gosden and Malafouris’ discussion of things in motion resonates with the Italian theoretical physicist Carlo Rovelli’s arguments concerning time and events (Rovelli 2017:96–97). Rovelli is concerned to distinguish between things and events:

The difference between things and events is that *things* persist in time; *events* have a limited duration. A stone is a prototypical ‘thing’; we can ask ourselves where it will be tomorrow. Conversely, a kiss is an ‘event’. It makes no sense to ask where the kiss will be tomorrow. The world is made up of networks of kisses, not of stones.

The basic units in terms of which we comprehend the world are not located in some specific point in space. They are – if they are at all – in a *where* but also in a *when*. They are spatially but also temporally delimited: they are events.

Here Rovelli is arguing that stones (the kinds of objects that archaeologists routinely deal with) are like everything else in the universe: they are events<sup>1</sup>; they do not persist as things in and of themselves; they exist because of their network of relationships (for similar kinds of arguments made by archaeologists, see Lucas 2012; Fowler 2013; Díaz-Guardamino 2021). If certain kinds of relations persist as events, the stone will persist (for example, if it is carefully curated in a museum collection); if not, the stone will crumble and disappear (for example, the stone is subject to forces of crushing during demolition work). I will return to a consideration of events when I discuss multiples at the end of the paper.

I now want to return us to considering prehistoric archaeology while keeping in the back of our minds some of these debates around processes, things, and events. A concern with the issue of process also motivated the recent *Making a Mark* project, which examined mark-making practices in the Neolithic of Britain and Ireland. The *Making a Mark* project set out to examine Neolithic artefacts across Britain and Ireland using digital imaging techniques (Jones & Díaz-Guardamino 2019, 2021). To do so, we focused

on three key regions: southern England and East Anglia; the Irish Sea region; and finally, the Northeast of Scotland. Each region is associated with distinct geologies and distinctive forms of artefact. I will not discuss all of the material geologies examined by the project here; instead, I will select and present an artefact, or group of artefacts, from each region as an illustration of some of the processes I have discussed above.

### The Garboldisham mace head

The Garboldisham macehead was dredged from the river Little Ouse, Norfolk, in the mid-1960s (Edwardson 1965). It is a spectacular example of a group of ‘mace heads’ – implements made of either antler, flint, or stone with a hole drilled possibly for mounting on a wooden shaft or handle (Roe 1968). The artefact from Garboldisham dates to 3240–3104 cal BCE (56.4% probability) and was probably deliberately discarded in the river in prehistory. It was recorded using digital imaging techniques, including Reflectance Transformation Imaging (RTI) and Photogrammetry, to enhance the evidence of mark-making and the three-dimensional characteristics of the artefact (Jones et al. 2017).

The macehead, fashioned from the burr of a red deer antler, was decorated with three spirals carved using a flint implement in the body of the antler (Figure 12.1). The spirals are drawn with an eye to the physical characteristics of the antler; their sinuous lines curve around the form of the antler, making it difficult to fully comprehend the totality of the design. Instead, our eyes must move with the line of the individual spirals around the antler; the movement of the line drawn in the antler offers us a guide around the peculiar three-dimensional form of the object. The spirals are drawn with careful attention to the affordances of the antler and are fitted to its specific dimensions. We can see the way in which one spiral is fitted into the space forming the edge of the antler. The spirals are drawn over an extended period. Using digital imaging, we have detected a stratigraphy of marking (Jones & Díaz-Guardamino 2019:44–47). The making of one spiral is interrupted by a series of striations (evidence for the smoothing or polishing of the surface of the object); the mark of the spiral then continues over the top of these striations, indicating two phases of mark-making. Digital microscope analysis also revealed that the spirals were not only carved over a single episode; they were also re-carved (Jones & Díaz-Guardamino 2019:46). Interestingly, the spiral motifs on the surface of this artefact are not common in this region of England and are echoed in the passage tomb art of Ireland (see also Bradley et al. 2019 for relationships between spiral motifs and Irish passage tomb art).

The carving of the Garboldisham mace head forces us to recognise that mark-making is an activity that involves close attention to the qualities



**FIGURE 12.1** Above: RTI image of decoration on the Garboldisham macehead, Norfolk. Below: three views of the Garboldisham macehead (image: courtesy of Moyes Hall Museum).

and affordances of specific materials. In addition, mark-making involves a relational dynamic in which the relationship between maker and materials is established and re-established as a series of events. This kind of relationship is amply demonstrated by my next case study.

### **Manx plaques**

The slate plaques from the Isle of Man (which is situated in the centre of the Irish Sea) are an unusual form of finely worked artefact. There are only six of these artefacts presently known to archaeologists (Figure 12.2). Five of them were discovered during the upgrade of Ronaldsway airport during World War II and are derived from a probable Neolithic dwelling (Bruce et al. 1947). The sixth, from Ballavarry in the north of the island, was

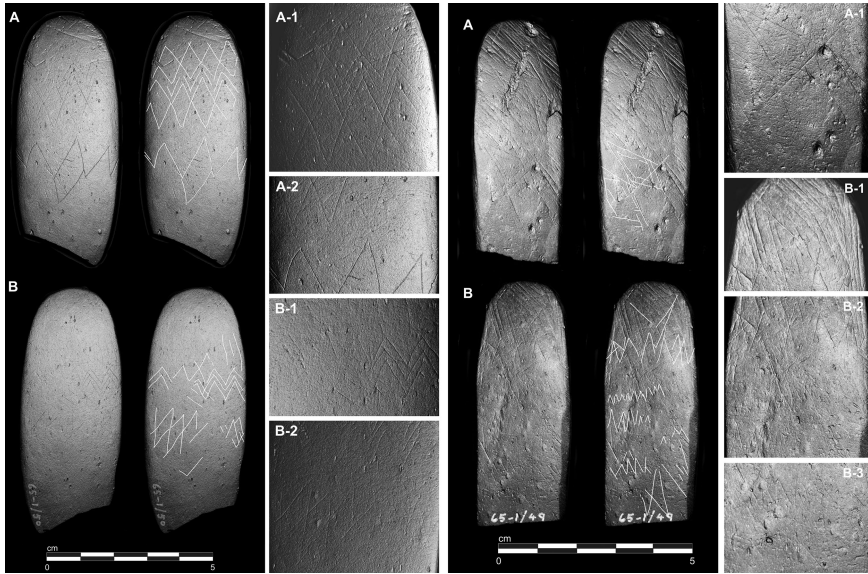

FIGURE 12.2 RTI images of the Manx plaques from Ronaldsway (image: courtesy of the Manx Museum).

discovered in a Neolithic pit during a commercial excavation project in the 1980s (Garrad 1984).

These artefacts are fashioned in the form of miniature Neolithic stone axes (Piggott 1954:350). They have complex life histories, as after being fashioned, they are eventually snapped in two and decorated (Jones et al. 2016). They are in fact fragmented, but fragmentation occurs before these artefacts are marked. Interestingly, the processes of fragmentation of slate plaques seem to parallel the fragmentation of the polished stone axes quarried on the island, of which around 25 of a total of 191 known axes (13% of the total) are cleanly broken across the centre of the axe before deposition (Jones et al. 2016:9).

Based on practical experimentation, marking on the slate plaques is probably executed with a fine stone or flint implement, though – owing to the fineness of the slate – fingernails are also effective marking implements.

Several of the plaques, recorded using digital imaging techniques, show evidence of having been extensively reworked (Jones et al. 2016:5–8). The plaques are decorated with a series of registers of motifs, and in a number of cases, motifs are erased and revised. The fine grain of the slate affords these revisions. The motifs on the surface of these artefacts are best paralleled in the design of contemporary Neolithic Grooved Ware pottery, and Grooved Ware is associated with the plaques from Ronaldsway (Burrow 1997, 1999). There is also a close similarity between the motifs found on the plaques and

the finely incised motifs on the large slate standing stone at Cronk yn How, itself probably dated to the 3rd millennium BCE (Darvill et al. 2005).

The plaques are palimpsests, in the true sense of the word, and in this case, mark-making is not a matter of record; marking is a repetitive practice a continued intra-active engagement between people and materials. In this way, mark-making is a process of unknowing, a continued grasping towards establishing greater connections between humans, materials, and place. The fine grain of the slate affords not only revision but also continued intra-action. Again, these artefacts are composed of a series of events, some of which may involve fragmentation or mark-making.

Similar kinds of intra-active engagement can be observed in the next case study.

### Carved stone balls

My final example is not a single artefact, but a larger category of artefacts: the carved stone balls of Northeast Scotland. Many of these artefacts have been found as stray finds, and until recently their dates were uncertain. We now know, on the basis of stratified finds from Neolithic settlements in Orkney and the Hebrides, that these artefacts date from the 31st to the 28th centuries cal. BCE (Jones & Díaz-Guardamino 2019:104).

Carved stone balls are numerous in number (there are over 400 of these objects known; numbers vary in the literature from 411 to 425, and they continue to be discovered in museum collections and excavations), but they defy easy description and classification. Since these objects first received archaeological attention and entered museum collections, they have puzzled archaeologists. What are they for? Why were they made?

I wanted to reassess these artefacts by examining the process of their making. In doing so, I argue that we are better considering carved stone balls as materials-in-motion, whose form comes to take the shape it does through a dynamic intra-action between material and maker (Jones & Díaz-Guardamino 2019:103–121; Jones 2020a). I will argue that what marks these artefacts out is not what they are, but what they achieve.

My re-assessment of carved stone balls began with a workshop in November 2013 in the sculpture studio of Winchester School of Art, UK, organised in collaboration with Ian Dawson and Louisa Minkin (Jones 2016). In the company of fine art and archaeology students, we made six-knobbed carved stone balls (known as type 4b after Marshall's 1977 classification) from plaster. We wanted to understand the processes of making these artefacts, and one of the clear outcomes of the workshop was the realisation that the series of types classified by archaeologists for these artefacts (e.g. Marshall 1977) were in fact simply stages in the sequence of making, or sequences in a *chaîne opératoire* (Jones & Díaz-Guardamino 2019; Jones 2020a).

This sequence begins with roughing out a sphere, smoothing it, or polishing it, then beginning to divide it with a series of circles. The inter-spaces between these circles are then carved out, leaving distinct knobs projecting outward. These knobs might then be further decorated by carving into their surface.

The workshop led me to consider carved stone balls not as fixed types or forms but as the result of working processes. The next stage of analysis involved recording carved stone balls in museum collections using digital imaging techniques, including RTI and photogrammetry (Jones & Díaz-Guardamino 2019). Digital analysis revealed plentiful evidence for the various stages of the manufacture of carved stone balls. These included peck marks from the roughing out of balls, detected on at least four examples.

In other cases, it was possible to observe evidence for partial working, as when the knobs of several carved stone balls were roughly defined but not worked further.

It is also possible to observe evidence for revision during the carving of carved stone balls (Figure 12.3). A knobbed ball from Clatchard, Newburgh, Fife, exhibits evidence for revision during working, as peck marks crosscut the grooves cut into the surface of several of the knobs. The organisation of the design was evidently revised during the manufacturing process.

This ongoing exploration of material, the process of taking shape, is also generative; it produces new forms and new ways of engaging with materials. We can consider this when we examine carved stone balls on a larger scale. Carved stone balls have a distinctive geographical distribution, with a focus on Northeast Scotland and eastern Scotland (from Caithness in the north to Fife in the south). There are also regional clusters in Orkney and the Hebrides and small groups found in Northern Ireland and northern England. An analysis of the geology of these artefacts shows that some of them must have been exchanged from the main regional centre in Northeast Scotland, but in each regional cluster many of them are also locally made (Jones & Díaz-Guardamino 2019; Jones 2020a). This does not seem to conform to the models of gift exchange we know of for other Neolithic artefacts (e.g. for polished stone axes; Bradley & Edmonds 1993). How are we to explain this? I argue that this pattern of exchange and local production equates to a form of knowledge transfer, or transmission of knowledge.

Local materials were almost certainly used to make carved stone balls, though many of them were also probably circulated between different regions of Scotland. Here, making is significant, but making appears to be associated with processes of learning: learning how to master the stoneworking skills to produce these complex artefacts and transferring these skills between regions. Once these skills were learned many of these artefacts were discarded, often midway through the process of making them.

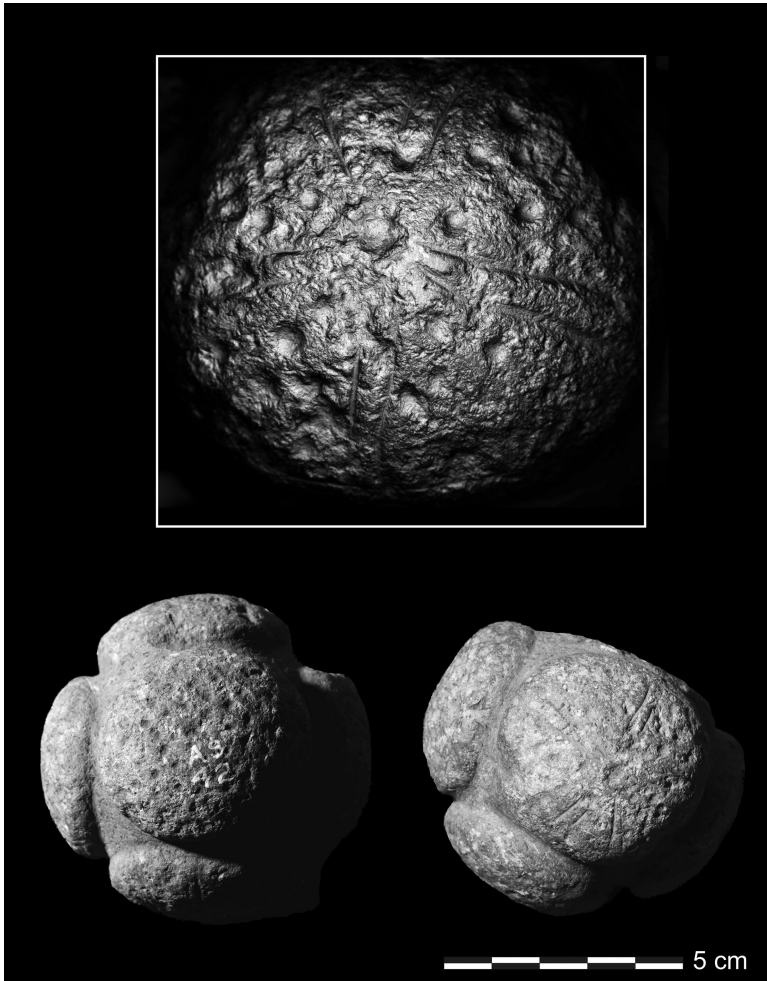

**FIGURE 12.3** The carved stone ball from Clatchard, Fife. Above: RTI image showing revision of decoration on the knob of the ball. Below: two views of the carved stone ball from Clatchard (image: courtesy of National Museums Scotland).

### **Making decorated artefacts in Neolithic Britain and Ireland**

I have now presented three classes of artefacts, or groups of artefacts. In each case, we can see that these artefacts are composed of locally derived materials, but they are carved with designs that have a much wider currency. In effect, marking artefacts with designs from other places allowed mark makers to ‘fold’ other places into local assemblages. It is possible to detect an emerging network across Britain and Ireland during the Middle Neolithic, around the

time the Garboldisham mace head was carved, and this network continues to expand and shift into the later Neolithic, when the Manx plaques and carved stone balls were produced (Jones & Díaz-Guardamino 2021).

Many portable, decorated artefacts are the result of close attention to the morphological characteristics of certain materials. In some cases, such as the Garboldisham macehead, this engagement is not singular but repetitive. It is not sufficient to simply attend to materials during mark-making; instead, mark-making also involves a process of re-engagement. Decorated artefacts were not simply made; they were caught up in an ongoing process of making and re-making (Jones & Díaz-Guardamino 2019:197–208). Decoration was not simply a one-off act of differentiation; it was a process of continual re-engagement, a process in which relationships were continually re-established.

One of the clearest examples of this are the slate plaques from the Isle of Man (Jones et al. 2016). Here, slates were fashioned to resemble the form of polished stone axes and subsequently broken. After this, they were marked with finely incised designs. Many of these designs are then erased and revised. The differing properties of slate are explored throughout these processes: the ability of slate to be shaped, broken, marked, and erased.

Decoration was a connective activity, establishing connections between disparate regions of Britain and Ireland, and these connections shifted and changed over time as the artefact was revised and re-marked. One of the consequences of decoration as a connective process is that it is possible for decorated artefacts to have multiple connections. In that sense, we could describe decorated artefacts as *multiple objects*.

### Multiple objects and multiplicities

The concept of ‘multiple objects’ is easily misunderstood and requires some explanation. When discussing ‘multiple objects’, I do not refer to artefacts made of multiple components, such as the hafted cutting implements of the Scandinavian Mesolithic composed of a series of microliths mounted either side of a bone shaft, known as composite knives or stone-edged bone implements (Swe. *Steneggad benspets*). Examples include F1911, Kanaljorden, Motala, Sweden (Hallgren et al. 2021), Oleni Ostrov, grave 100 (Burdukiewicz 2005:340), and Bloksbjerg, Zealand, Denmark (Clark 1975). Such an implement is made from several components: bone, resin(?), and numerous microlithic blades, and is thereby arguably multiply authored (Finlay 2003). In the scheme first formulated by John Chapman (2000), this artefact would probably be best described as a kind of accumulation; it would be an object in which each component connotes an enchainment relationship. The act of bringing together these components offers a powerful symbol of cohesion.

By discussing ‘multiple objects’, I instead consider such objects as multiplicities. I have previously discussed ‘multiple objects’ and drew inspiration for this concept from the work of sociologist Anne Marie Mol (2002) and geographer Steve Hinchliffe (2010). Both scholars analyse different kinds of objects – Mol discusses the disease of lower-limb atherosclerosis in a Netherlands hospital, while Hinchliffe discusses a gardening project in Small Heath, Birmingham, UK – but both define ‘multiple objects’ in a similar way. ‘Multiple objects’ are things that are not unified entities but are enacted in multiple locations and through multiple practices. In the terminology used by Rovelli at the beginning of this paper, ‘multiple objects’ are composed of differing and overlapping *events*.

We can understand multiple objects in a similar way to our understanding of ‘dividual’ persons. Chris Fowler (2004:8) has provided the clearest archaeological articulation of the concept: ‘dividuals’ describe a “state of being in which the person is recognised as being composite and multiply-authored”. He goes on to state that “the person is comprised of multiple features with different origins” (Fowler 2004:8). Just as we conceptualise a single entity – a person – to be composed of multiple and overlapping relationships, so too do I argue that objects are also composed of multiple and overlapping relationships. My account of multiplicity differs from the notion of multiple authorship we are familiar with from biographical accounts of artefacts. In these kinds of accounts, objects emerge as inert things whose value and significance are bestowed on them as they shift from one set of relationships to another. The notion of biography is constructivist in that it posits a conception of an artefact as a unified entity shaped by multiple perspectives. In contrast to this, ‘multiple objects’ are composed of a series of different and overlapping relations; the artefact is not a unified entity but is enacted and shaped by the relations it is composed of. The coherence of the artefact is repeatedly enacted and re-enacted by these relationships.

‘Multiple objects’ or multiplicities are not parts of greater wholes that have been fragmented, nor is a multiplicity a manifold expression of an overarching or unified concept. A multiplicity is a complex structure that does not reference a prior unity. Gavin Lucas usefully discusses multiplicity in his recent book *Making Time* (Lucas 2021). He notes the multiplicities and discontinuities evident in felt time and physical time and remarks on the way in which temporal multiplicity is “bound up with the material multiplicity of reality, whether our bodies or other objects” (Lucas 2021:24). This point underlines the fact that ‘multiple objects’ are not simply composed of multiple overlapping relations, but that these relations are ongoing and in motion. In that sense, in their motion, ‘multiple objects’ are also involved in processes of making new relations. Drawing on the work of art historian George Kubler (1962), Lucas also highlights the multi-temporal character

of artefacts. He analyses the temporal stratification of objects to show that objects are always composites of newer and older elements, or what Kubler describes as convention and invention (Kubler 1962:24). The very form and manufacture of artefacts, therefore, involve multiple layers embodying different places, times, and practices.

To consider ‘multiple objects’ and multiplicities further, let us now turn from these theoretical abstractions and look again at the three artefacts previously discussed in this paper.

We will begin with the carved stone balls of Northeast Scotland. There are over 400 of these artefacts, so in a literal sense, they are multiple! But again, this is not what I intend to mean by ‘multiple objects’ or multiplicities. The carved stone balls, as a regionally defined class of artefacts, are inter-referential. There is not a singular template for making carved stone balls. My research has shown that, although there are certain stages of working, each stage yields multiple possibilities (Jones & Díaz-Guardamino 2019:114–115), and the form of the artefact emerges as it is worked (Jones 2020b). There is a sense of restless motion in these artefacts. The working of each carved stone ball relates to the working of other balls while also relating to other contemporary stone working techniques, and the designs carved on these artefacts relate to the design of contemporary Grooved Ware pottery as well as other designs in rock art and passage tomb art.

As I have previously argued, we can also consider the Manx plaques as multiple objects (Jones et al. 2016). The Manx plaques are also a regionally defined group of artefacts. They are made of local slates, but their miniature scale and resemblance to other Neolithic artefacts – like stone axes – relates them to similar practices in Ireland and Wales, while their organised registers of designs may even echo the schist plaques of Neolithic and Copper Age Portugal and Spain (Lillios 2008). Locally, their decoration also enacts a network of relationships: the designs on their surfaces relate them to Grooved Ware pottery and the designs marked on standing stones on the island.

Now we turn to the artefact I discussed at the beginning of this paper: the Garboldisham mace head. How is it possible to describe this as a ‘multiple object’ when there is only a single example? But look closer, and we notice that the Garboldisham macehead belongs to a class of mace heads made of antler, which also skeuomorphically relate to similar mace heads made of flint (Jones & Díaz-Guardamino 2019:123–130). Although the Garboldisham mace head was deposited in Norfolk in eastern England, it was also decorated with designs more common to Irish passage tombs.

In each case, it is possible to see that artefacts, whether classes of artefacts, such as carved stone balls, or singular artefacts, like the Garboldisham mace head, are composed of multiple relationships. Each relates themselves as members of a typological class (Fowler 2017). But we can also observe that

practices of visualisation are important in the making of these artefacts. The motifs carved on the artefacts are enactments enfolding artefacts into wider networks of relations (Jones 2017). In some cases, as with the Manx plaques, it is possible to see that the form and decoration of these artefacts relate them to dense networks of local, regional, and inter-regional connections. In other cases, as with the Garboldisham mace head and carved stone balls, we can observe that decoration relates these artefacts to much larger emergent networks of relations. Working with these artefacts appears to do something, enacting novel networks of relations. Sometimes this might be for shorter periods of time, as with the Manx plaques, whose decoration is ephemeral. On other occasions, these relationships might change during making, as with the carved stone balls, whose decorative motifs were altered as they were being worked. The decoration on these artefacts seems in each case to be a visual enactment – the visual enactment of changing relations. Critically, these modes of decoration also have their own temporalities. For example, when the spiral motifs were carved on the Garboldisham macehead, these kinds of motifs were novel components of an emergent network tying them to developments in eastern Ireland. By contrast, when we find spiral motifs carved on carved stone balls, these motifs are now ‘old fashioned’ and relate to several centuries of practice, presumably now relating the making of carved stone balls with the emerging network associated with Grooved Ware pottery (Jones & Díaz-Guardamino 2021).

It is also worth emphasising that the relational networks that compose ‘multiple objects’ are not only composed of human relationships. They are composed of a host of forces, both human and non-human. This is apparent when we analyse the making of artefacts and note – as with the making of carved stone balls, the ephemerality and fragility of the slate from which the Manx plaques are made, and the affordance of the antler used for making the Garboldisham mace head – that the qualities of materials also compose these networks. My analysis of these ‘multiple objects’ places emphasis on the changing constitution of materials as they are altered and participate in changing networks of relationships.

We cannot describe these artefacts in terms of singular relationships. They are related as members of wider classes of artefacts, while their decoration also places them in wider fields of relationships, also relating to wider temporalities; furthermore, these networks of relations include the relations between materials and humans. These different ways of relating overlap. The decorated portable artefacts of Neolithic Britain and Ireland are multiple objects precisely because each of these artefacts is composed of a series of different and overlapping relationships.

## Conclusion

I have been concerned to highlight the clear concern with social and material processes in John Chapman and Bisserka Gaydarska’s work on fragmentation (Chapman 2000; Chapman & Gaydarska 2007). Chapman and Gaydarska’s

work alerts us to much more than broken things. I would argue that their work shifted us beyond thinking about objects as fixed entities. We could now begin to appreciate that things existed in time and space (a realisation that biographical analyses also helped to promote; e.g. Gosden & Marshall 1999). Focusing on fragmenting objects meant that the relationships entailed by objects could be physically, conceptually, and socially dispersed across landscapes. Equally, John and Bissierka also recognised that the processes that pertained for fragmented objects also worked for intact objects. If we could talk about the way in which fragments enchain relations, conversely, we could also discuss the way enchain relations were brought to bear when whole objects were accumulated together in hoards or deposits.

My aim in this paper has been to refocus attention away from artefacts as entities, whether fragmented or whole, and towards the relations that compose artefacts.

Rather than viewing artefacts as whole or fragmented entities that produce enchain relations, I argue that networks of relations produce artefacts. What I want to abstract from Chapman and Gaydarska's work is the emphasis on relations rather than objects, fragmented or otherwise.

These networks of relationships will always be multiple and overlapping. It is very rare that we excavate artefacts that stand alone and bear no relationship with other things. Is it even possible to conceive of an artefact that stands alone in this way? If we take as an example the ostensibly 'unique' group of artefacts known as the Folkton Drums – small carved chalk artefacts deposited with a child burial in Neolithic Yorkshire – my previous research has shown that these artefacts were also stylistically connected to other practices in Neolithic Britain and Ireland (Jones 2012), while subsequent research has revealed other chalk drums of a similar character (Jones & Díaz-Guardamino 2019; Garrow & Wilkin 2022).

Even these apparently 'unique' artefacts can be shown to possess multiple relationships with other artefact forms and types. Indeed, the multiplicity of things is the bedrock on which we base typological analysis (Fowler 2017) and chronological analysis (Lucas 2021:64–83). But artefacts are all multiple in different ways, and our task as archaeologists is to analyse how different relationships enact and produce artefacts and how these relations change over time. How are artefacts connected to other things? Do these connections change over time? What are the social implications of these changing relationships? Answering questions like these will enable us to appreciate the multiple characters of the artefacts that we excavate and analyse and their role in prehistoric social relations.

## Note

- 1 Rovelli's definition of events here differs from the definition of event in the work of Ferdinand Braudel (1980). Braudel distinguishes between events, conjunctures and structures, and events can be short (days, weeks) against the longer-term duration of conjunctures and structures (years, decades, centuries). Given

Rovelli's interest in quantum theory his events are likely to be infinitesimally short durations. For the purposes of this paper, I regard events as of the longer durations discussed by Braudel.

## References

- Bradley, R. & Edmonds, M. 1993. *Interpreting the axe trade. Production and exchange in Neolithic Britain*. Cambridge: Cambridge University Press.
- Bradley, R. et al. 2019. After the axes? the rock art at Copt Howe, north-west England, and the Neolithic sequence at Great Langdale. *Proceedings of the Prehistoric Society* 85: 177–192. <https://doi.org/10.1017/ppr.2019.5>
- Braudel, F. 1980. *On History*. London: Weidenfeld and Nicholson.
- Bruce, J.R. et al. 1947. A Neolithic site at Ronaldsway, Isle of Man. *Proceedings of the Prehistoric Society* 13: 139–160. <https://doi.org/10.1017/S0079497X00019678>
- Burrow, S. 1997. *The Neolithic culture of the Isle of Man: a study of the sites and pottery*. Oxford: BAR.
- . 1999. The Ronaldsway pottery of the Isle of Man: a study of production, decoration, and use. *Proceedings of the Prehistoric Society* 65: 125–143. <https://doi.org/10.1017/S0079497X00001961>
- Burdukiewicz, J.M. 2005. Microlithic technology in the Stone Age. *Journal of the Israel Prehistoric Society* 35: 337–351.
- Chapman, J. 2000. *Fragmentation in archaeology: people, places and broken objects in the prehistory of South Eastern Europe*. London: Routledge. <https://doi.org/10.4324/9780203759431>
- Chapman, J. & Gaydarska, B. 2007. *Parts and wholes: fragmentation in prehistoric context*. Oxford: Oxbow.
- Clark, G. 1975. *The earlier Stone Age settlement of Scandinavia*. Cambridge: Cambridge University Press.
- Darvill, T. et al. 2005. The Cronk yn How stone and the rock art of the Isle of Man. *Proceedings of the Prehistoric Society* 71: 283–331. <https://doi.org/10.1017/S0079497X00001043>
- Díaz-Guardamino, M. 2021. The temporality of stone: late prehistoric sculpture in Iberia. In: S. Hüglin et al. (eds) *Petrification processes in matter and society*. Cham, Switzerland: Springer, 99–113. [https://doi.org/10.1007/978-3-030-69388-6\\_9](https://doi.org/10.1007/978-3-030-69388-6_9)
- Edwardson, A.R. 1965. A spirally decorated object from Garboldisham. *Antiquity* 39: 145. <https://doi.org/10.1017/S0003598X00105071>
- Finlay, N. 2003. Microliths and multiple authorship. In: L. Larsson et al. (eds) *Mesolithic on the move*. Oxford: Oxbow, 169–176.
- Fowler, C. 2004. *The Archaeology of personhood: an anthropological approach*. London: Routledge. <https://doi.org/10.4324/9780203583210>
- . 2013. *The emergent past: A relational realist archaeology of Early Bronze Age mortuary practices*. Oxford: Oxford University Press. <https://doi.org/10.1093/acprof:osobl/9780199656370.001.0001>
- . 2017. Relational typologies, assemblage theory and Early Bronze Age burials. *Cambridge Archaeological Journal* 27(1): 95–109. <https://doi.org/10.1017/S0959774316000615>
- Gamble, C. 2007. *Origins and revolutions: human identity in Earliest Prehistory*. Cambridge: Cambridge University Press.

- Garrad, L. 1984. Rescue excavations 1980-1982: Ballavarry. *Proceedings of the Isle of Man natural history and antiquarian society* 9(2): 163–168.
- Garrow, D. & Wilkin, N. 2022. *The world of stonehenge*. London: British Museum Press.
- Gosden, C. & Marshall, Y. 1999. The cultural biography of objects. *World Archaeology* 31(2): 169–178. <https://doi.org/10.1080/00438243.1999.9980439>
- Gosden, C. & Malafouris, L. 2015. Process Archaeology (P-Arch). *World Archaeology* 47(5): 701–717. <https://doi.org/10.1080/00438243.2015.1078741>
- Hallgren, F. et al. 2021. Den rituella miljön under tidigatlantisk tid. In: F. Hallgren et al. (eds) *Kanaljorden, Motala. Rituella våtmarksdepositioner och boplatsslämnin-  
gar från äldre stenålder, yngre stenålder och järnålder. Arkeologisk förundersökning och särskild arkeologisk undersökning*. Västerås: Stiftelsen Kulturmiljövård, 257–364.
- Hinchliffe, S. 2010. Working with multiples: a non-representational approach to environmental issues. In: B. Anderson & P. Harrison (eds) *Taking-place: non-representational theories and geography*. Farnham: Ashgate, 303–320.
- Jones, A.M. 2012. *Prehistoric materialities: becoming material in prehistoric Britain and Ireland*. Oxford: Oxford University Press. <https://doi.org/10.1093/acprof:osobl/9780199556427.001.0001>
- . 2016. Making carved stone balls: art, experimental practice and archaeological research. In: H. Chittock, & J. Valdez-Tullett (eds) *Archaeology with art*. Oxford: Archaeopress, 1–12.
- . 2017. The art of assemblage: styling Neolithic art. *Cambridge Archaeological Journal* 27(1): 85–94. <https://doi.org/10.1017/S0959774316000561>
- . 2020a. An archaeology of affect: art, ontology and the carved stone balls of Neolithic Britain. *Journal of Archaeological Method and Theory* 27(3): 545–560. <https://doi.org/10.1007/s10816-020-09473-8>
- . 2020b. Images and forms before Plato: the carved stone balls of North-east Scotland. In: I.-M. Back Danielsson & A.M. Jones (eds) *Images in the making*. Manchester: Manchester University Press, 90–103. <https://doi.org/10.7765/9781526142856.00015>
- Jones, A.M. & Díaz-Guardamino, M. 2019. *Making a mark: image and process in the Neolithic of Britain and Ireland*. Oxford: Oxbow. <https://doi.org/10.2307/j.ctvz80kw>
- . 2021. Making a mark: process, pattern and change in the British and Irish Neolithic. *Cambridge Archaeological Journal* 32(3): 389–407. <https://doi.org/10.1017/S0959774321000512>
- Jones, A.M. et al. 2016. From artefact biographies to ‘multiple objects’: a new analysis of the decorated plaques of the Irish Sea region. *Norwegian Archaeological Review* 49(2): 113–133. <https://doi.org/10.1080/00293652.2016.1227359>
- Jones, A.M. et al. 2017. The Garboldisham Macehead: its manufacture, date, archaeological context and significance. *Proceedings of the Prehistoric Society* 83: 383–394. <https://doi.org/10.1017/ppr.2017.10>
- Kubler, G. 1962. *The shape of time. Remarks on the history of things*. New Haven, CT: Yale University Press.
- Lillios, K.T. 2008. *Heraldry for the dead: memory, identity, and the engraved stone plaques of Neolithic Iberia*. Austin, TX: University of Texas Press.
- Lucas, G. 2012. *Understanding the archaeological record*. Cambridge: Cambridge University Press. <https://doi.org/10.1017/CBO9780511845772>

- . 2021. *Making time. The archaeology of time revisited*. London: Routledge. <https://doi.org/10.4324/9781003089445>
- Marshall, D. 1977. Carved stone balls. *Proceedings of the Society of Antiquaries of Scotland* 108: 40–72.
- Mol, A.-M. 2002. *The body multiple: ontology in medical practice*. Durham: Duke University Press. <https://doi.org/10.2307/j.ctv1220nc1>
- Piggott, S. 1954. *The Neolithic cultures of the British Isles*. Cambridge: Cambridge University Press.
- Roe, F.E.S. 1968. Stone maceheads and the latest Neolithic cultures of the British Isles. In: J.M. Coles & D.D.A. Simpson (eds) *Studies in ancient Europe*. Leicester: Leicester University Press, 145–172.
- Rovelli, C. 2017. *The order of time*. London: Penguin.

# 13

## BREAKING, MAKING, DISMANTLING AND REASSEMBLING

### Fragmentation in Iron Age Britain

*Helen Chittock*

#### **Introduction**

This chapter explores the fragmentation of human-made things in Iron Age (IA) Britain. It summarises often-subtle evidence for potential deliberate fragmentation before focusing on evidence for the dismantling and reassembly of composite Middle-Late IA metal objects. This phenomenon saw components of complex, often decorated, metalwork reused in repairs or used to constitute parts of new objects. The motivations behind this practice were multi-faceted they likely related partially to the usefulness of components as reusable units. It is argued, however, that some repairs were important in the ongoing visual design of valued and long-lived ‘objects in process’.

The chapter then turns to its central question: what is the difference between fragmentation and dismantling? Carefully dismantling a composite object to reuse its components seems, at first glance, to be at odds with more violent acts of fragmentation. However, this chapter concludes that the results of these two processes are actually closely aligned.

#### **Forms of fragmentation in Iron Age Britain**

A large proportion of the IA objects excavated from archaeological sites in Britain are broken when they are found. There are a whole range of potential reasons for this. Objects broken either during use or accidentally were perhaps discarded when repair was not possible or desirable. Taphonomic and material processes within archaeological sites can lead to the breakage and degradation of objects during the time they are buried, and the disturbance of archaeological contexts and redeposition of finds in later periods can lead

to damage. Similarly, fragile objects can also be easily broken at the point of recovery. All of these circumstances are likely to have contributed to the broken IA finds that form part of the archaeological record in Britain, as well as the deliberate processes this chapter discusses.

Studies of broken objects in other prehistoric European contexts have revealed a range of deliberate fragmentation processes. Chapman and Gaydarska's work on Mesolithic, Neolithic and Chalcolithic south-eastern Europe, for example, includes the systematic breakage of items like salt pots and anthropomorphic figurines and the possible movement of fragments between sites (Chapman 2000:49–104; Chapman and Gaydarska 2007:177–182). Knight's work on Bronze Age (BA) metalwork from south-west Britain (e.g. 2021, 2022:23–26) and Larsson's work on flint artefacts from south Sweden (2015) assess evidence for the use of heating processes in deliberate breakage. Overt and widespread evidence for the deliberate fragmentation of human-made things in IA Britain is seemingly less visible, but this part of the chapter aims to explore strands of evidence that can help to begin the disentanglement of accidental and deliberate breakage.

### *Fragmenting Iron Age bodies*

The absence of widespread, archaeologically visible burial rites and funerary monuments in IA Britain, apart from in Middle Iron Age (MIA) East Yorkshire and Late Iron Age (LIA) south-east England, has been much discussed by archaeologists (e.g. Harding 2016:2; Lamb 2022). There are multiple possible explanations for this apparent paucity of evidence; however, Harding has suggested that the redefinition of archaeological notions of burial is needed to understand IA mortuary practices (Harding 2016:3–4). Practices of depositing human remains in IA Britain existed on a spectrum. Evidence for these practices ranges from more archaeologically visible burials of whole bodies to the deposition of individual human bones or bone fragments in features such as pits, ditches and occupation layers (Harding 2016: *ibid.*), also encompassing more complete disintegration of the dead through cremation. The varied processes of fragmentation relating to this spectrum have seen attention from archaeologists working on the IA across Europe (e.g. Harding 2016; Armit 2010, 2012; Rebay-Salisbury 2010; Torres-Martínez et al. 2021; Lamb 2022). This chapter will not revisit these approaches to fragmented bodies in detail, but this body of work provides important context for the discussion of other forms of fragmentation that follows.

### *Creating fragments*

While the archaeological recovery of partial human remains is, in many cases, strongly indicative of the deliberate disarticulation of bodies, direct evidence

for the deliberate fragmentation of IA objects is rarer, at least in Britain. In some cases, evidence of specific technical processes used in fragmentation is visible. For example, a triangular fragment of bronze sheet recovered from a hoard of cauldrons deposited in the 4th or 3rd century BCE at Chiseldon, Wiltshire (south-west England) had been cut from a cauldron and its edges hammered (Baldwin & Joy 2017:59). Other fragments from the same deposit were derived from cauldrons that had been more forcibly torn apart (Baldwin & Joy 2017:60). Watts has written about quernstone fragments from Glastonbury and Meare Lake Villages, M-LIA sites in Somerset (south-west England). While many of the quern stones will have broken accidentally through use, potential evidence for deliberate breakage was also present. Heating had possibly been used as a method of aiding breakage in one case, and in other cases, querns were broken into numerous refitting fragments (Watts 2017:183–185).

Missing fragments from certain types of objects in secure archaeological contexts can also be suggestive of deliberate fragmentation. In East Yorkshire (north-east England), single pots were often included as grave goods within large Middle-LIA cemeteries. Missing sherds from the rims of otherwise refitting vessels (Giles 2012:133–134) may suggest that the breakage of some of these pots was deliberate, with these missing sherds being kept by mourners or deposited elsewhere.

Examples of material evidence for deliberate fragmentation in the IA, such as those given above, are seemingly quite rare. However, there is ample evidence from across IA Britain for the specific treatment and use of fragments, with both archaeological and regional contexts aiding in interpretations. The study of depositional practices can add weight to suggestions about deliberate fragmentation because it speaks to the ways that fragments were treated. For example, Watts' suggestion that some querns may have been fragmented deliberately is strengthened by the incorporation of numerous refitting fragments into specific types of deposits at Glastonbury Lake Village (Watts 2017:185). Watts suggests that the practice of breaking querns may have been symbolic of the endings of relationships, events, or places, or that it may have reflected a need to dispose of particular querns (Watts 2017:185). It is also possible that quern fragments needed to be generated in order to produce particular deposits, with deliberate fragmentation fulfilling a creative role, rather than a destructive one.

Hill's work on deposition in IA Wessex analyses assemblages of artefacts and ecofacts from the fills of features at chalk downland sites located mainly in Hampshire (1995). Most of these objects were broken when deposited, but different categories of objects were treated in different ways. 'Small finds', such as metal finds and worked bone, were generally broken accidentally through use rather than deliberately, but still deposited in specific, deliberate ways (1995:108). Some pots were possibly deliberately broken, while

other sherds were interpreted as having been accidentally broken and curated before deposition (Hill 1995:109). Sherds of different fabrics and from different vessel types were also deposited in different ways (Hill 1995: *ibid.*). The many deposits examined by Hill were the results of particular processes, whether everyday processes or more special processes (see Garrow 2012). In many cases, the specific treatment of fragments, whether deliberately or accidentally created, suggests that they had their own functions.

Fragments of objects that are 'out of time' (Knight et al. 2019:4), or out of place can also provide information on specific treatments that might be less archaeologically visible within assemblages of more ubiquitous fragments. For example, across East Anglia and the East Midlands during the Later IA, there is evidence for the use and circulation of small amounts of non-local *La Tène*-decorated pottery, which was unusual across these regions (Hill with Horne 2003:180). Hill suggests that both entire vessels and sherds of this 'exotic' pottery were curated over long periods of time and deposited in specific ways (Hill with Horne 2003: *ibid.*).

### *Assembling fragments*

When assemblages of fragmented bodies and objects are viewed holistically, seemingly innocuous pieces of broken objects can sometimes take on new significance. Armit, in his work on headhunting in IA Europe, describes a deposit at Cnip wheelhouse on the Isle of Lewis (north-west Scotland). The deposit, dating to the 1st century CE, was created within a disused building before the foundations of a new building were laid out. It included a smooth, rounded stone, two potsherds, the upper part of a human cranium and another skull fragment (likely human but possibly animal) (Armit 2012:3). Despite the survival of thousands of animal bones at the site, only three other human bone fragments were recovered (Armit 2012:3–4). The deposition of the two sherds of pottery and smooth unworked stone with some of the only fragments of human remains at Cnip makes it apparent that they were specifically selected to be part of a significant deposit (Armit 2012:3–4, 220).

In his discussion of this deposit, Armit gives examples of other IA deposits from across Britain containing cranial fragments (Armit 2012:4–7), demonstrating that IA interests in this specific type of fragment had broad spatial and temporal reaches. In these examples, association with human remains has perhaps lent other fragmented finds a particular kind of significance and a particular kind of archaeological visibility. The fragments of objects in the Cnip deposit described above might have been viewed differently had they not been deposited with some of the only fragments of human remains from the site. However, deliberate deposits, including fragmented finds without the inclusion of human remains, were very common across Britain during the IA and the preceding and proceeding periods. Deposits such as these have

been variably termed ‘special’, ‘structured’, ‘exceptional’, ‘odd’ and ‘notable’ deposits (see e.g. Hill 1995; Garrow 2012; Davies 2018, 2022), signifying the purposeful nature of these deposits but generally moving away from using the term ‘ritual’ (Brück 1999, although see Chadwick 2012:295–296; Davies 2022:64–65).

Armit discusses IA deposits in the context of the medicine bundles of the Mandan, a Native American tribe of the Great Plains (2012:219–220). Medicine bundles are small collections of sacred objects assembled both by individuals or communities and kept in bundles, packs, bags or sacks commonly made from skin, cloth or woven matting (Armit 2012: *ibid.* See Pauketat 2013:43–58 for a detailed study of North American medicine bundles). Medicine bundles vary in composition and function, but, as Armit writes, some comprise ‘collections of apparently ordinary objects that were nonetheless invested with considerable symbolic and spiritual significance’ (2012:220). It is possible that some assemblages of IA fragments share similarities with these collections of objects, with the combination of seemingly ordinary things creating powerful effects in ways that are not always immediately archaeologically obvious.

This section of the paper has ranged widely across IA Britain, discussing fragmented objects and deposits of a wide range of dates and types. It has introduced the varied processes that fragmentation can entail: the use of heat, force and skill, as well as less deliberate processes occurring as a result of use, wear and taphonomy. It has also touched on some of the ways that fragments, whether generated deliberately or accidentally, were combined to create meaningful assemblages.

Writing on Middle and Late BA Britain, Brück draws comparisons between the treatment of bodies, things, and materials to suggest that fragmentation, transformation and regeneration were “central cultural metaphors through which people conceptualised the passage of time, the production of food and other categories of material culture and the creation of social agents”, relating to BA personhoods (2006:310). Given the wide-ranging evidence for the specific treatment of fragments in IA Britain, it seems that fragmentation retained its significance as an important cultural metaphor (although the nature of its changing significance is a topic for another paper<sup>1</sup>).

### **Dismantling and reassembling Iron Age metalwork**

From around 400 BCE, a new kind of metalwork began to appear in Britain (see Garrow et al. 2009:102). This assemblage has often been characterised by archaeologists as including complex decorative designs incorporating curvilinear patterns and abstracted images. This style of decoration is often known as Early Celtic Art (although for the discussion of issues

with both this category of objects and its name, see Gosden & Hill 2008 and Chittock 2021:5–17, for example). Some object types within this category are also complex in the ways they were made and assembled, being made from numerous components and sometimes incorporating multiple materials. Figure 13.1, an exploded diagram of the Kirkburn sword (East Yorkshire) (Stead 2006:253), demonstrates the huge number of individual components assembled to make the sword and scabbard, which incorporated iron, bronze, glass, and horn (Gosden & Hill 2008:10). Producing an object like this would, therefore, have involved bringing together materials from varied sources and utilising a range of technical skills, likely involving multiple individuals. Examples of other object types within this assemblage of complex MIA metalwork include torcs (Machling & Williamson 2020; Joy 2019); buckets; tankards (Horn 2015); cauldrons (Joy 2014; Baldwin & Joy 2017); shields (Hitchcock 2019, 2022); and horse gear (e.g. Lewis 2015; see also Maguire 2021 for LIA Irish horse gear).

Objects of Early Celtic Art were not only artfully designed and skilfully produced to create visually engaging effects; they were also useful. Cyril Fox wrote of Early Celtic Art that “there is nothing of ‘Fine Art’ about it” (1958:v), highlighting the problems with defining these objects as ‘art’ in a modern, Western sense. He went on to describe the placement of IA ornament on ‘purposeful things’, describing the ‘sense of style’ employed by craft-people to create objects that were not only beautiful but ‘well-shaped’ and ‘well-balanced’ (1958:v). Recent studies of objects of Early Celtic Art by the author have explored evidence for the purposes and use of these objects, showing that they were well-used, often repaired, and sometimes modified in other ways (e.g. Chittock 2019, 2020, 2021). Evidence exists for the possibility that some items of composite M-LIA metalwork were dismantled and that their components were reassembled to form new objects or added to objects to replace lost or damaged components. This phenomenon and the needs it caters to will be discussed below.

### *Case studies from Iron Age East Yorkshire*

On March 20th, 1868, while quarrying for chalk on the Grimthorpe estate around 4 kilometres from Pocklington (East Yorkshire), Mr G. Hopper discovered the crouched inhumation burial of a young man (Mortimer 1869, 1905). Recent radiocarbon dating has suggested that the individual buried here died between 360 and 160 BCE (Garrow et al. 2009). In addition to human remains, the burial contained a spearhead, 16 bone points, a sword in its scabbard and the fittings of a shield – a set of grave goods that has earned this burial the name ‘The Grimthorpe Warrior’. The sword and shield from this burial were examined as part of the author’s PhD research (see Chittock 2021), where evidence for the use, repair and modification of a sample of metalwork finds from East Yorkshire was examined.

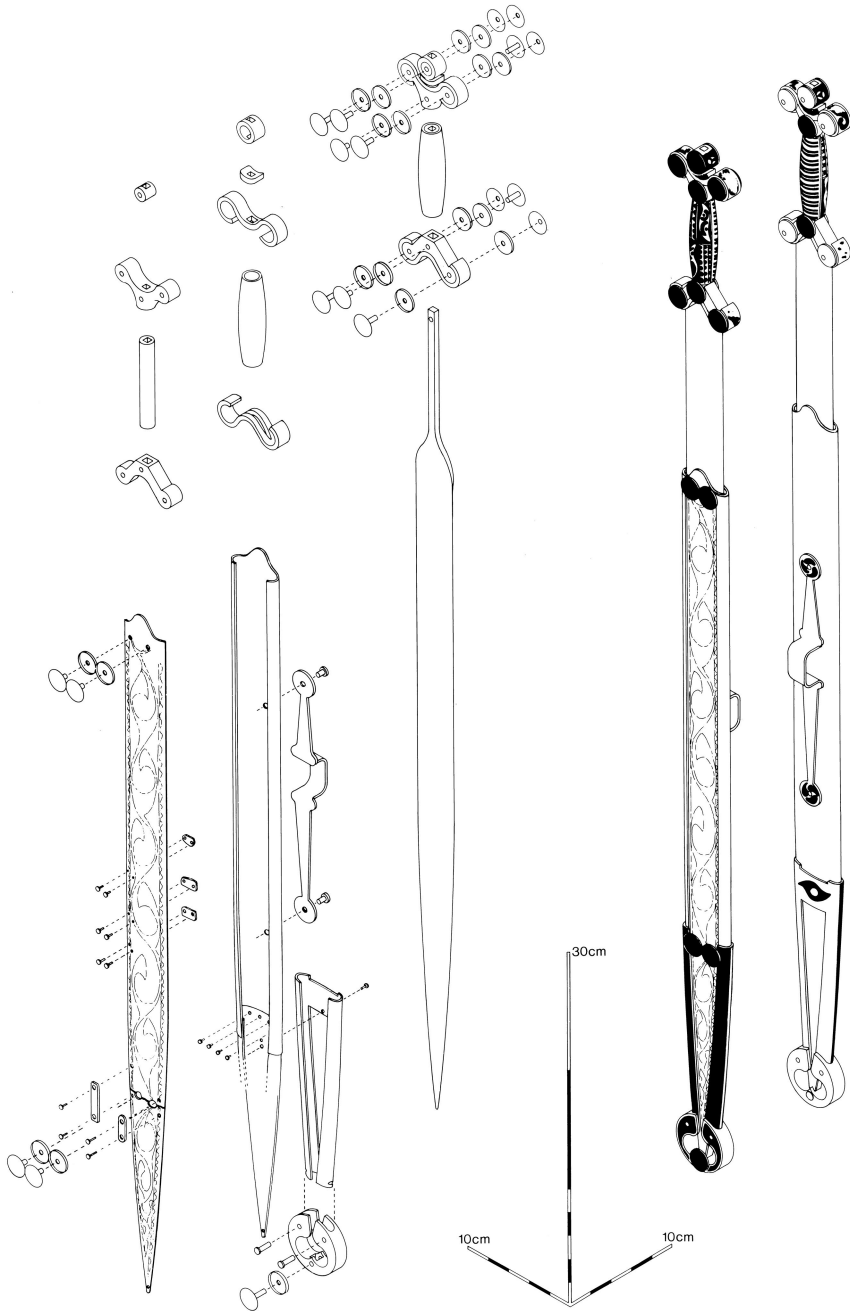

**FIGURE 13.1** An exploded diagram of the Kirkburn sword, East Yorkshire, showing the way numerous components were assembled (© Trustees of the British Museum).

The assemblage referred to as the Grimthorpe Shield has traditionally been thought of as including six copper alloy fittings, although it has recently been noted by Matthew Hitchcock that a small *La Tène*-decorated disc from this assemblage is actually likely to be a scabbard mount, closely resembling an example fixed to the top of the front plate of a sword scabbard from the River Thames at Amerden (Hitchcock 2022:145–147). It is possible this fitting derives from the scabbard within the burial, but the upper portion of the scabbard has not survived, making it impossible to link the two finds with certainty. Given the evidence presented below, it also seems possible that this was a scabbard fitting reused as a shield fitting. The remaining five fittings from the Grimthorpe shield assemblage consist of a lenticular boss, decorated with a symmetrical design formed from straight and curved lines and in-filled with fine inscribed lines; two crescent-shaped bronze sheets decorated on their outer edges by a border filled by a geometric, blocked pattern, formed through repoussé and chasing; and two bronze ‘ribs’, each measuring around 270 mm long and perforated at each end. Due to the early date of excavation, the exact positions of the fittings within the grave were not recorded, making it difficult to know whether they were deposited while attached to a wooden or leather backing to form a shield or as an assemblage of separate fittings (see Chittock 2021:90). The retention of five copper alloy rivets from the burial lends weight to the idea that the fittings were attached to a backing, although their origins within the grave and the objects they belonged to are uncertain. Ian Stead’s hypothetical reconstruction of the shield’s position in the grave (Stead et al. 1969: fig. 11) takes into account a written description of the shield recorded by Dr Wilson of Pocklington at the time of its discovery (Mortimer 1905:347) to suggest that it was laid over the body of the deceased (Figure 13.2).

In terms of wear, the shield has clearly seen use, particularly on the two crescent-shaped fittings. These had visible tears and breaks that had been mended by rivets that fixed the fittings onto their wooden or leather backing, as evidenced by numerous rivet holes. Damage to both crescent-shaped fittings suggests a heavy blow from a bladed weapon (Hitchcock 2022:147–148), and two substantial dents in one of these fittings support the idea that the shield was used in combat. Furthermore, the rivet holes in both the two crescent-shaped fittings are of many different sizes and are unevenly spaced around the circumferences of the fittings. There are also far more holes than would be necessary to fix the fittings to their backing. It is suggested that these fittings were fixed to a number of different backings at different times. Use-wear around these rivet holes supports this assertion. The patterns of tearing around the edges of some of the rivet holes suggest that the two crescent-shaped fittings were forcibly torn from their backing on at least one occasion. The central boss and two ribs, conversely, bore no such evidence, being relatively free from signs of wear other than some damage to the end of one of the ribs, which may be post-depositional.

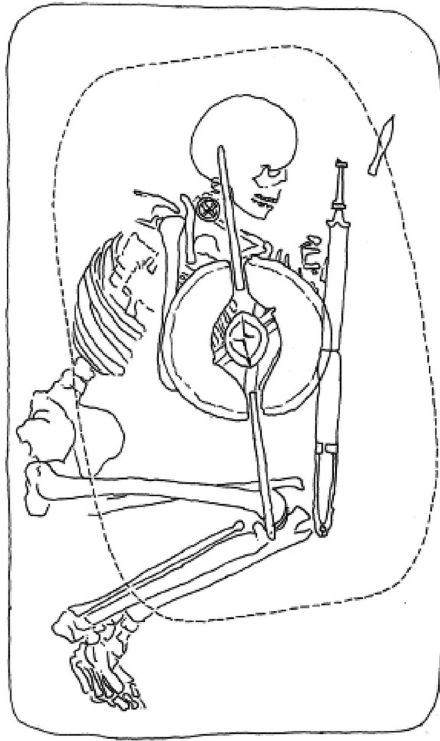

**FIGURE 13.2** The hypothetical positioning of the Grimthorpe shield fittings within the grave from which they were recovered (illustration: H. Chittock after Stead et al. 1969, figure 11 with kind permission). The dashed line represents Stead's interpretation of where the wooden or leather body of the shield may have lain, although no traces of this have survived.

It is suggested that this group of shield fittings was derived from at least two different shields, an idea supported both by evidence for use and damage and by their varied decorative styles (Chittock 2021:90). They may have been brought together at the time of the burial as part of the funerary event. They may also have been collected to form the shield over a longer period of time as trophies, gifts, mementos, heirlooms, antiques (see Chittock 2019), or simply as replacements for damaged, lost or broken components.

Similar phenomena have been noted in the context of other types of composite objects from IA East Yorkshire, excavated from graves as parts of MIA cemeteries located on and around the Wolds, chalk hills arcing through

the west and north of the modern county. Carts or chariots perhaps represent the ultimate composite IA objects. They were assembled from numerous wooden components, metal and bone or antler fittings, and more transient components such as leather and rope (see Giles 2012:193-204). All but two of the near-complete chariots known from IA Britain are from East Yorkshire and its neighbouring counties, where a tradition of chariot burial existed in the region's MIA cemeteries. Evidence suggests that some chariots included mismatched or replacement components, suggesting a range of practices relating to the dismantling and reassembly of these complex composite objects.

The Ferry Fryston chariot, excavated just outside East Yorkshire in West Yorkshire (Boyle et al. 2007), was formed from a set of mismatching components, including two differently sized wheels, one bearing a decorative copper alloy strip and the other plain. The terrets (rein rings) were a 'sham' set made from copper alloy sheet wrapped around silt or clay cores (Boyle et al. 2007:138-141; Giles 2012:197). It would not have been possible to successfully drive this chariot very far at all, leading Giles to suggest that the vehicle was assembled at the time of the funeral, with components having been donated or recycled from other dismantled vehicles before it was wheeled into the grave (Giles 2012:198, 203). Other East Yorkshire chariots showing evidence of similar practices include the Kirkburn chariot, which was dismantled before burial but included a replacement wheel (Stead 1991:40-57), which had potentially been driven as part of the chariot for some time (Chittock 2021:79), and a visually diverse set of metal fittings (Garrow & Gosden 2012:218). The Garton Station chariot, also dismantled before burial, included five terrets, one of which was differently decorated and constructed than the other four. It was also much larger, with the variation in size going beyond the size gradient usually seen in sets of terrets (Chittock 2021:79). Is it possible that the larger terret originally belonged to a different set? These examples create a contrast with other, more uniform sets of chariot fittings (Chittock 2021: *ibid.*).

Objects of personal ornament from MIA graves in East Yorkshire also show evidence of having been assembled from the dismantled components of other objects. A copper alloy wheel-headed pin excavated from a grave at Danes Graves was decorated with cylindrical beads of coral that had originally been strung, probably as part of a necklace, as shown by small perforations (Stead 1979:77; Giles 2013). Giles also discusses sets of glass beads from East Yorkshire's cemeteries, many of which were found in groups at the necks of deceased individuals, probably representing necklaces (Giles 2012:147-148). Evidence exists in these assemblages of beads for beads being swapped in and out of sets, and Giles suggests a range

of circumstances in which beads were exchanged, lent, or bequeathed. As small, tactile, wearable things, they make ideal mnemonic devices, kept in sets that can be easily split or added to (Giles 2012:149). At Arras cemetery, for example, one set of beads seemingly included newer and older beads, suggesting that some beads were curated or handed down through generations (Giles 2012: *ibid.*).

### *Motivations for reuse and reassembly*

The possible reasons behind the incorporation of reused components into new objects are complex and multi-faceted. Components from dismantled objects, perhaps salvaged following damage, are likely to have made convenient replacements for use in repair processes, saving time and resources. Repair and reuse are likely to have been extremely commonplace in IA Britain (and other pre-modern societies – see Duckworth and Wilson 2020 on recycling and reuse in the Roman Empire). This is certainly suggested by the numerous small repairs seen on items of IA metalwork. However, not all the objects described above fit neatly into this model of reuse and repair.

It has been observed that, on some objects of IA metalwork, including those incorporating reused components, repairs and modifications are often unhidden. This in itself could be due to the skill level of the individual carrying out a repair. However, some repairs are made decorative in themselves, seemingly emphasising and celebrating the processes of damage and mending (Chittock 2020, 2021). In this context, the ‘conspicuous accretion’ (Chittock 2020:164) of visible repairs and modifications on items of long-lived and well-used metalwork can be viewed as an important aspect of what made these objects valuable (Chittock 2020, 2021). Viewing potential dismantling and reassembly in this setting suggests that the motivations for this may have been related not only to the convenient reuse of components but also to the ongoing visual design of important ‘objects in process’.

### *Dismantling and reassembly beyond East Yorkshire*

The paragraphs above have focussed on examples of dismantling and reassembly from the region of East Yorkshire. Tentative suggestions can perhaps be made about similar practices relating to other items of metalwork from further afield across IA Britain. This paper has already mentioned Baldwin and Joy’s work on the Chiseldon cauldrons from Wiltshire (south-west England) (Baldwin & Joy 2017), which revealed evidence both for the careful and forceful dismantling of cauldrons. Joy’s work on cauldrons across Britain and Ireland suggests that the dismantling of cauldrons was

a phenomenon that extended far beyond this site, occurring perhaps for the purposes of reusing fragments or so that certain cauldron components could be deposited in specific ways (Joy 2014:342–343; Baldwin & Joy 2017:115). IA cauldrons were long-lived objects, often repaired at multiple points during their lives (Joy 2014), and it seems possible that pieces from fragmented or dismantled cauldrons were reused in these processes. Some cauldrons from the Chiseldon assemblage were repaired using fancy patches, which mended stress fractures formed during the manufacturing process, seemingly forming part of the assemblage of IA objects with visible repairs (Baldwin & Joy 2017:47–48). The Grotesque torc, from Hoard L at Snettisham, Norfolk (East Anglia), was repaired in a visible way using parts of a tubular torc and twisted torc, in addition to pieces of wire and strip (Joy 2019; Machling & Williamson 2020). This is an object thought to be at least 100 years old when it was deposited in the late 2nd or early 1st century BCE (Joy 2019:469). Its repairs have been interpreted as either an accumulation of components over a long period of time (Joy 2019) or as the result of hasty repairs performed by non-specialists (Machling & Williamson 2020). The Torrs pony cap, from Dumfries and Galloway (south-west Scotland), is a highly repaired decorative cap dating to 300–200 BCE, designed to be worn by a pony (Figure 13.3). The cap includes two horns, which were added to the object as modifications during the IA (Briggs 2014:350–352) and may represent objects that had other functions before they were incorporated into this exuberant piece of horse gear. Since their discovery in 1812, they have been discussed at some points as possible drinking horns (Briggs 2014:351) and more recently as fittings from the ends of a chariot yoke (Hunter 2015:99). IA sword scabbards are often found to have been repaired in various ways (see Stead 2006), and it seems likely that components from dismantled scabbards were used in this process (see Chittock 2021:97–100<sup>2</sup>). Hitchcock also discusses the potential for the dismantling and reassembly of IA shields in a wider discussion of the variety of repairs and modifications made to these objects (Hitchcock 2022:132–133). An intriguing, heavily repaired miniature shield from the Salisbury Hoard (see Stead 2000) is patched together from at least two pieces of bronze sheet. Presumably, it was not damaged through combat, being just a few centimetres in length, but perhaps it embodies the concepts used to assemble some IA shields from pieces of others, as seen in the Grimthorpe example described above.

Further research is needed to assess the extent of these practices in Britain. These examples aim to show that there is potential for the investigation of dismantling and reassembly practices beyond East Yorkshire. They suggest that the East Yorkshire finds existed in a wider world where the reuse of fragments and components for varied reasons was commonplace.



**FIGURE 13.3** A photograph of the Torrs Pony Cap (Dumfries and Galloway, Scotland) (© National Museums Scotland).

### **Fragmentation vs dismantling**

It will be evident from the preceding section of this paper that there is much work to be done on the potential for dismantling and reassembly within the wider assemblage of IA finds, both in terms of the extent of this phenomenon

and the development of techniques for its recognition. While these aims are beyond the scope of this text, the discussion that follows will consider the idea of dismantling and reassembly in relation to other forms of later prehistoric fragmentation. The key question to be explored here is: what is the difference between dismantling and fragmentation?

In their work on the Chiseldon cauldrons, Baldwin and Joy specifically define ‘damage’ as “major loss of a section or part of the cauldron putting the object beyond repair by a non-specialist” (2017:58). Archaeological definitions of fragmentation perhaps share commonalities with this statement. Fragmentation, in archaeological research, has generally been used to refer to the breaking of objects in a way that renders them unusable for their original purposes but that results in distinct fragments. Knight uses the word ‘destruction’ in a similar way (2022), employing a Damage Ranking System to categorise the extent of damage to metalwork from BA southwest Britain and using this to suggest levels of intentionality (2020, 2022). Knight’s work on damage and destruction links these processes closely to deposition, and Fontijn’s work on destruction in BA Europe sees deposition as part of the destruction process, a process that creates value through the damage and disposal of valuable objects (2019).

In one sense, dismantling appears to be a very different process from fragmentation or destruction. It implies the careful deconstruction of a composite object using specialist skill, resulting in pieces that were intended for reuse. ‘Fragmentation’ and ‘destruction’, on the other hand, tend to refer to more forceful acts, resulting in broken objects. However, as the body of work on fragmentation in archaeology that has grown from the work of Chapman and Gaydarska shows (Chapman 2000; Chapman & Gaydarska 2007), the pieces of fragmented, damaged, or destroyed objects are also highly useful and were often created for specific intended purposes. In this sense, dismantling and fragmentation, while involving different physical processes, lead to similar outcomes. Both types of process can result in components that have a visible and perhaps mnemonic association with the object they were once part of. These components can be used in new ways and incorporated into new assemblages while still being part of their original assemblages.

Brittain and Harris (2010) have examined the ways in which Chapman and Gaydarska’s work on fragmentation (Chapman 2000; Chapman & Gaydarska 2007) has been applied to a wide range of archaeological periods and materials. In Chapman and Gardarska’s work on the Balkan Mesolithic, Neolithic and Copper Ages, deliberate fragmentation is fundamentally linked to enchainment, the idea that when people exchange things or fragments of things, recognisable for their mnemonic and metaphorical properties, they are also exchanging themselves (Chapman 2000:5). This idea links the trajectories of objects, people and places and sits specifically within the notion that later prehistoric personhoods were not individual but dividual or relational

(Brittain and Harris 2010:583–584; see also Fowler 2004). Chapman, however, does state that fragmentation and enchainment do not necessarily follow each other (2000:37), and Brittain and Harris take this idea further as they consider fragmentation, enchainment and personhood as individual processes that can be interlinked in different ways, depending on cultural and historical context (2010). Exploring the potential nature of enchainment in the context of IA personhood is beyond the scope of this paper, considering the complex nature of the evidence for the fragmentation of both objects and people during this period. However, it could be argued that a form of enchainment was in play with the dismantling of distinctive objects linked to places, events and communities and the use of dismantled components as parts of new objects in a way that emphasised their mnemonic properties.

### **New types of practice for new objects**

It can be argued, based on the wide-ranging evidence for deliberate fragmentation traditions across later prehistoric Europe, that fragmentation was an important concept in later prehistoric worldviews, practices, and ontologies, interpreted and enacted in different ways within different temporal and geographical contexts. Garrow et al. (2009:111) draw a comparison between the characteristic assemblage of MIA metalwork from Britain, which is represented by a small number of complex and unique objects with numerous components, and the depositional traditions of the Late Bronze Age (LBA), which consumed huge numbers of far more standardised and less complex bronze objects. They write that rather than being concerned with quantity, as in the LBA (Needham et al. 1998), the makers and users of MIA metalwork were concerned with quality (Garrow et al. 2009:111). It could be argued that the emergent object types of MIA Britain resulted in new types of fragmentation. These were metal objects formed from numerous components, with many major parts made from iron but also using copper alloys in different ways from their BA counterparts. The technologies of fragmentation evident in some BA metalwork assemblages (Knight 2020, 2022) perhaps did not translate into IA assemblages. But, more significantly, the highly composite objects of the MIA and LIA perhaps presented new opportunities in terms of fragmentation because they could be dismantled or disassembled, as opposed to being ‘broken’ in the conventional sense. The resulting components can also be reassembled to create new objects with visible stories.

### **Acknowledgements**

I’m very grateful to the editors of this volume for inviting me to take part in the fantastic symposium that the volume draws on. Many thanks also to the other delegates for their stimulating and inspiring discussion and to the anonymous

reviewers of this paper for their valuable feedback. Thank you to Matthew Hitchcock for allowing me to read and cite unpublished work (and for reading this paper too), to Melanie Giles for her kind comments, and to Alex Davies for providing access to his work. Finally, thank you to Andrew Meirion Jones, J.D. Hill and Jody Joy, who supervised my PhD, on which parts of this paper are based, and to Matthew Knight for our many valuable discussions about fragmentation.

## Notes

- 1 Davies' work on changing depositional practices in the Thames Valley region of southern England during the Bronze and Iron Ages (2022) offers a model for the study of subtle changes in the use of fragments in deposits over time, which would be very useful for future studies.
- 2 See also a LIA scabbard recovered from the River Thames at Battersea, London (c. 120 BCE–43 CE) (Stead 2006:176–177), which appears to have an ill-fitting replacement loop plate.

## References

- Armit, I. 2010. Porticos, pillars and severed heads: the display and curation of human remains in the southern French Iron Age. In: K. Rebay-Salisbury et al. (eds) *Body parts and bodies whole: changing relations and meanings*. Oxford: Oxbow, 90–100.
- . 2012. *Headhunting and the body in Iron Age Europe*. Cambridge: Cambridge University Press.
- Baldwin, A. & Joy, J. 2017. *A Celtic feast: the Iron Age cauldrons from Chiseldon, Wiltshire*. London: British Museum Press.
- Boyle, A. et al. 2007. Site D (Ferry Fryston) in the Iron Age and Romano-British periods. In: F. Brown et al. (eds) *The archaeology of the A1 (M) Darrington to Dishforth DBFO road scheme*. Lancaster: Oxford Archaeology North, 121–159.
- Briggs, S. 2014. The Torrs Chamfrein or Head-piece: restoring 'A very curious relic of antiquity'. In: C. Gosden et al. (eds) *Celtic art in Europe: making connections*. Oxford: Oxbow, 341–355.
- Brittain, M. & Harris, O. 2010. Enchaining arguments and fragmenting assumptions: reconsidering the fragmentation debate in archaeology. *World Archaeology* 42(4): 581–594. <https://doi.org/10.1080/00438243.2010.518415>
- Brück, J. 1999. Ritual and rationality: some problems of interpretation in European archaeology. *European Journal of Archaeology* 2(3): 313–344. <https://doi.org/10.1179/eja.1999.2.3.313>
- . 2006. Fragmentation, personhood and the social construction of technology in Middle and Late Bronze Age Britain. *Cambridge Archaeological Journal* 16(3): 297–315. <https://doi.org/10.1017/S0959774306000187>
- Chadwick, A. 2012. Routine magic, mundane ritual: towards a united notion of depositional practice. *Oxford Journal of Archaeology* 31(3): 283–315. <https://doi.org/10.1111/j.1468-0092.2012.00390.x>
- Chapman, J. 2000. *Fragmentation in archaeology: people, places, and broken objects in the prehistory of south-eastern Europe*. London & New York: Routledge. <https://doi.org/10.4324/9780203759431>

- Chapman, J. and Gaydarska, B. 2007. *Parts and wholes: fragmentation in prehistoric context*. Oxford: Oxbow.
- Chittock, H. 2019. Iron Age antiques: assessing the functions of old objects in Britain from 400BC to AD100. In: M.G. Knight et al. (eds) *Objects of the past in the past: investigating the significance of earlier artefacts in later contexts*. Oxford: Archaeopress, 77–97.
- . 2020. Pattern as patina: Iron Age ‘kintsugi’ from East Yorkshire. In: I.-M. Back Danielsson & A. M. Jones (eds) *Images in the making: art, process, archaeology*. Manchester: Manchester University Press, 149–167.
- . 2021. *Arts and crafts in Iron Age East Yorkshire: a holistic approach to pattern and purpose, c. 400BC-AD100*. Oxford: BAR.
- Davies, A. 2018. *Creating society and constructing the past: social change in the Thames Valley from the Late Bronze Age to the Middle Iron Age*. Oxford: BAR.
- . 2022. Unusual deposition of Bronze Age and Iron Age settlements and hillforts in the Upper and Middle Thames Valley. *Oxford Journal of Archaeology* 41(1): 63–84. <https://doi.org/10.1111/ojoa.12233>
- Duckworth, C. & Wilson, A. 2020. *Recycling and reuse in the Roman economy*. Oxford: Oxford University Press.
- Fontijn, D. 2019. *Economies of destruction: how the systematic destruction of valuables created value in Bronze Age Europe c. 2300–500 BC*. London & New York: Routledge. <https://doi.org/10.4324/9781315109879>
- Fowler, C. 2004. *The archaeology of personhood: an anthropological approach*. London: Routledge. <https://doi.org/10.4324/9780203583210>
- Fox, C. 1958. *Pattern and purpose: a survey of Early Celtic art in Britain*. Cardiff: The National Museum of Wales.
- Garrow, D. 2012. Odd deposits and average practice. A critical history of the concept of structured deposition. *Archaeological Dialogues* 19(2): 85–115. <https://doi.org/10.1017/S1380203812000141>
- Garrow, D. et al. 2009. Dating celtic art: a major radiocarbon dating programme of Iron Age and Early Roman metalwork in Britain. *Archaeological Journal* 166(1): 79–123. <https://doi.org/10.1080/00665983.2009.11078221>
- Garrow, D. & Gosden, C. 2012. *Technologies of enchantment? exploring Celtic art: 400 BC to AD 100*. Oxford: Oxford University Press. <https://doi.org/10.1093/acprof:osobl/9780199548064.001.0001>
- Giles, M. 2012. *A forged glamour: landscape, identity and material culture in the Iron Age*. Oxford: Windgather Press.
- . 2013. The Danes Graves wheel-headed pin (The Yorkshire Museum). In: M. Endt-Jones (ed.) *Coral: something rich and strange*. Liverpool: Liverpool University Press, 47–48.
- Gosden, C. & Hill, J. D. 2008. Introduction: re-integrating Celtic Art. In: D. Garrow et al. (eds) *Rethinking Celtic Art*. Oxford: Oxbow Books, 1–14.
- Harding, D.W. 2016. *Death and burial in Iron Age Britain*. Oxford: Oxford University Press.
- Hill, J.D. 1995. *Ritual and rubbish in the Iron Age of Wessex: a study on the formation of a specific archaeological record*. Oxford: BAR.
- Hill, J.D. with Horne, L. 2003. The pottery. In: C. Evans (ed.) *Power and island communities: excavations at the Wardy Hill Ringwork, Coveney, Ely*. Cambridge: Cambridge Archaeological Unit, 145–184.

- Hitchcock, M. 2019. Reframing the Iron Age shield. *Later Prehistoric Finds Group Newsletter* 12: 5–8.
- . 2022. *Shields in the British Iron Age: a critical archaeological approach*. Unpublished PhD Thesis, University of Manchester.
- Horn, J. 2015. Tankards of the British Iron Age. *Proceedings of the Prehistoric Society* 81: 311–341. <https://doi.org/10.1017/ppr.2015.15>
- Hunter, F. 2015. Powerful objects: the uses of art in the Iron Age. In: J. Farley & F. Hunter (eds) *Celts: art and identity*. London & Edinburgh: The Trustees of the British Museum & National Museums Scotland, 80–105.
- Joy, J. 2014. ‘Fire Burn and Cauldron Bubble’: Iron Age and Early Roman cauldrons of Britain and Ireland. *Proceedings of the Prehistoric Society* 80: 327–362. <https://doi.org/10.1017/ppr.2014.7>
- . 2019. A power to intrigue? Exploring the ‘timeless’ qualities of the so-called ‘Grotesque’ Iron Age torc from Snettisham, Norfolk. *Oxford Journal of Archaeology* 38(4): 464–475. <https://doi.org/10.1111/ojoa.12178>
- Knight, M.G. et al. 2019. Objects of the past in the past, In: M.G. Knight et al. (eds) *Objects of the past in the past: investigating the significance of earlier artefacts in later contexts*. Oxford: Archaeopress, 5–21.
- Knight, M. G. 2020. There’s method in the fragments: a damage ranking system for Bronze Age metalwork. *European Journal of Archaeology* 24(1): 48–67. <https://doi.org/10.1017/eea.2020.21>
- . 2022. *Fragments of the Bronze Age: the destruction and deposition of metalwork in south-west Britain and its wider context*. Oxford: Oxbow.
- Lamb, A. 2022. Iron Age mortuary practices in Britain: an assessment of current trends and their characteristics within contemporary north-western European traditions. *Proceedings of the Prehistoric Society* 88: 227–260. <https://doi.org/10.1017/ppr.2022.1>
- Larsson, L. 2015. Fragmentation during the Neolithic: transformation and enchainment from a south Swedish perspective. In: K. Brink et al. (eds) *Neolithic diversities: perspectives from a conference in Lund, Sweden*. Lund: Lund University, 233–240.
- Lewis, A. 2015. *Iron Age and Roman-era vehicle terrets from western and central Britain: an interpretive study*. Unpublished Ph.D. Thesis, University of Leicester.
- Machling, T. & Williamson, R. 2020. *Thoughts on the Grotesque torc and the Snettisham (Ken Hill) boards in the light of new research* [online]. <https://bigbookoftorcs.com/2020/09/22/thoughts-on-the-grotesque-torc/> [Accessed 15 October 2020]
- Maguire, R. 2021. *Irish Late Iron Age equestrian equipment in its insular and continental context*. Oxford: Archaeopress.
- Mortimer, J. 1869. Notice of an opening of an Anglo-Saxon grave at Grimthorpe, East Yorkshire. *The Reliquary and Illustrated Archaeologist* ix: 180–182.
- . 1905. *Forty years researches in British and Saxon burial mounds of East Yorkshire*. London: A. Brown & Sons.
- Needham S. et al. 1998. An independent chronology for British Bronze Age metalwork: the results of the Oxford radiocarbon accelerator programme. *Archaeological Journal* 154: 55–107. <https://doi.org/10.1080/00665983.1997.11078784>
- Pauketat, T. 2013. *An archaeology of the cosmos: rethinking agency and religion in ancient America*. Abingdon: Routledge. <https://doi.org/10.4324/9780203085189>

- Rebay-Salisbury, K. 2010. Cremations: fragmented bodies in the Bronze and Iron Ages. In: K. Rebay-Salisbury et al. (eds) *Body parts and bodies whole: changing relations and meanings*. Oxford: Oxbow, 64–71.
- Stead, I. et al. 1969. An Iron Age hill-fort at Grimthorpe, Yorkshire, England. *Proceedings of the Prehistoric Society* 34: 148–190. <https://doi.org/10.1017/S0079497X00013876>
- Stead, I. 1979. *The Arras culture*. York: The Yorkshire Philosophical Society.
- . 1991. *Iron Age cemeteries in East Yorkshire*. London: English Heritage Archaeological Report.
- . 2000. *The Salisbury hoard*. Stroud: Tempus.
- . 2006. *British Iron Age swords and scabbards*. London: British Museum.
- Torres-Martínez, J.F. et al. 2021. ‘Invisible Burials’ and fragmentation practices in Iron Age Europe: excavations at the Monte Bernorio necropolis (northern Spain). *Journal of Field Archaeology* 46(6): 399–413. <https://doi.org/10.1080/00934690.2021.1924435>
- Watts, S. 2017. The quernstones of Glastonbury and Meare. In: R. Shaffrey (ed.) *Written in stone: papers on the function, form, and provenancing of prehistoric stone objects in memory of Fiona Roe*. St Andrews: Highfield Press, 166–194.

# 14

## FUSING FRAGMENTS

### Repaired objects, refitted parts and upcycled pieces in the Late Bronze Age metalwork of Southern Scandinavia

*Karin Ojala and Anna Sörman*

#### **Introduction**

The metalwork from the Bronze Age has fascinated archaeologists since the birth of the discipline. Objects of bronze have been extensively collected, compiled and depicted. However, the presentation of the objects, especially in older literature, does not always correspond to what you find when you see them in real life. Behind the well-arranged typological series, reconstructions and well-preserved highlighted examples, there are also objects that are broken, fragmented, repaired or modified in different ways. Now increasingly recognised, bronze artefacts of the Nordic Bronze Age (NBA) with traces of repairs, modifications and reuse occur in museum collections (Oldeberg 1933; Madsen 2009; Skinner 2009; Thrane 2013; Hornstrup 2018; Horn & Karck 2019). There is a large variation in how these objects were mended. Some of the repairs were highly visible and changed the appearance of the objects, while others were more discreet. Sometimes, fragments or parts of objects have been used either to create new objects or to mend old artefacts. Such objects are therefore an important window into the life of fragments ‘after the break’, in a period when large quantities of broken metalwork were in circulation.

The topic of mended and modified NBA metalwork is not particularly well studied. Previous observations, primarily by Andreas Oldeberg in the first half of the 20th century (e.g. Oldeberg 1927, 1933, 1934, 1943), were entirely focused on the technical aspects of repairs. However, modifications probably also affected how items were regarded, used and valued. As shown by various archaeological, historical and ethnographic examples, alterations are not always only made due to functional necessity. This material evidence

stimulates wider reflection on fragmentable, ‘partible’ and composite objects and the ways in which different fragments invite reuse.

In this chapter, we explore some aspects of modified and mended metalwork in Late Bronze Age Scandinavia (c. 1100–500 BCE). We primarily study how fragments and pieces were added and reused in processes of repair and modification. We mainly include Swedish finds, although the discussion will also bring up examples from other parts of the NBA, an area covering southern Scandinavia and northernmost Germany, characterised by similarities in bronze metalwork (e.g. Baudou 1960; Sørensen 1987; Jantzen 2008).

Questions addressed are: What types of bronze objects have been mended or modified, and in what contexts have they been found? How were different objects repaired, modified, reassembled and repurposed? What ideas and values may have been connected to these modified items, and what can they reveal about the attitude towards and reuse of fragmented bronzes?

### The archaeology of repairs

Archaeologists from modern western consumer cultures have often approached the broken and fragmented with ethnocentric expectations about the universal preference for the complete and intact (Chapman & Gaydarska 2007; Chittock 2020). The incomplete and repaired might instead carry meaning, be an act of veneration and be integral to the objects’ biography (Chapman 2000; Chapman & Gaydarska 2007; Caple 2010:308; Chittock 2021:109). Over the last decades, interest in mended and modified objects has grown, not only regarding technical and functional aspects but also in view of their cultural implications (e.g. Willmott 2001; Jervis & Kyle 2012; Swift 2012; Verger 2019; Chittock 2020; Dumont 2022). Repairs to a treasured object might imply an *addition* rather than a diminution in value (see Chittock 2020). Mended, modified and reused bronze metalwork testifies to the choice of keeping it instead of simply re-melting and casting it into new objects.

Repairs constitute significant events in the object’s cultural biography and often embody shifts in its function, value and meaning (e.g. Dooijes & Nieuwenhuys 2007; Swift 2012). Helen Chittock (2020, 2021) has observed that reused pieces from various dismantled objects were intentionally reassembled in Iron Age metalwork in northern England (see also Chittock this volume). Composing wagons, shields and swords out of decorated pieces of various ages, styles and degrees of use-wear was a way to materialise, commemorate and facilitate oral histories about these objects (Chittock 2021:99–100). Other examples of modifications with meaning beyond the purely functional are the European LBA full-hilted swords, where the addition of locally made hilts onto exotic blades functioned as a visual and material process of acculturation (Dumont 2022).

This shows that we should approach these objects as *modified*, a definition that does not give preference to just one of the many reasons (the functional) that a broken object might be manipulated or reused post-manufacture (e.g. Martin 2012:62). An emphasis on manipulation rather than repair also acknowledges that integrating old parts onto other items might create enchainments that reinforce relations (Chapman 2000; Chapman & Gaydarska 2007; Chittock 2020). Thinking about what fragments or parts were brought with them into a reassembled or repaired item has the potential to reveal the deeper complexity behind how and why objects and fragments were used (e.g. Chittock 2020). This is one of the avenues for exploring the itineraries for some fragments ‘after the break’ (see Chapman & Gaydarska 2007). We would like to contribute to this reflection: what fragments add to practices of remaking and reuse; the accumulations of histories and relationships that might be involved; and more generally, approaches to fragmented materials at various times.

### **Bronze objects in Late Bronze Age southern Scandinavia**

In the LBA, copper alloys and bronze casting technology had been known in southern Scandinavia for hundreds of years. Traces of bronze casting, in the form of fragmented crucibles and moulds and occasionally also small pieces of metallic residue, are known from many different sites, both from long-house environments as well as burial and cult sites, indicating that bronze casting was a widespread practice throughout LBA southern Scandinavia (Levy 1991; Jantzen 2008; Sörman 2018).

Bronze objects were used in many spheres of society: as tools, body ornaments, dress attributes, drinking vessels, weapons, razors, ritual paraphernalia and more. The period had a very elaborate use of bronze; the metal dressed and accompanied many people, practices and ceremonies but was also used to mark and sacrifice to the spirited landscape through depositions. In the region, bronzes from the LBA are primarily found deposited in various wet or dry locations (Levy 1982:fig. 3-1; Rundkvist 2015:44–46). Nordic LBA hoard depositions are traditionally classed as ‘scrap hoards’, ‘sacrificial hoards’ or ‘single finds’ (e.g. Levy 1982). However, these functional divisions have been criticised as the material proves to be much more complex (e.g. Bradley 1990; Brück 2016; Fontijn 2019). Bronze objects are also occasionally found in burials, but only represent some of the object types in circulation. More rarely, objects or fragments are also found at settlements.

### **The archaeological sources and source criticism**

Collecting information about modified objects in the literature and museum catalogues is challenging. Many publications focus on whole, undamaged

objects and not broken, fragmented or repaired artefacts, which mirrors the traditional preference for pristine objects in typo-chronological studies (e.g. Montelius 1917; Baudou 1960). In addition, catalogues and secondary literature sometimes completely fail to mention if objects were mended. Many repairs or modifications have probably never been noticed, and still remain undetected today. Some of the ‘cast-on’ repairs (see *Fill-ups* further below) are hard to detect without X-radiography (Skinner 2009:31). Moreover, there are examples of LBA metalwork with repairs dating from the 19th or 20th century, both from museum contexts (e.g. Skinner 2009) and private collections (e.g. Swedish History Museum (SHM) 2549). Nevertheless, modern modifications and prehistoric repairs can often be distinguished due to differences in techniques and patina (Skinner 2009). Some bronze objects were mended with other materials in the LBA, as, for example, a crack on a hanging vessel that had been filled up with resin (Oldeberg 1934:9). This kind of repair work is not included in this study.

The archaeological source material presented in this study was collected through a search in museum catalogues (notably the SHM) and in archaeological literature. It was compiled (Table 14.1) and classified according to the type of manipulation (see the following section, Figure 14.1). Although not representing a full overview, this source material is large enough to reveal interesting tendencies in the handling of fragments in practices of repair and modification.

### **Repair work, manipulations and reuse of metalwork in Late Bronze Age Sweden**

Repaired objects occur both in the Early and LBAs (e.g. Oldeberg 1933, 1943; Kristiansen 1974; Thrane 2004, 2013; Melheim 2008; Skinner 2009; Nørgaard 2018:113). The LBA Nordic finds collected here, primarily from present-day Sweden, include four different types of repairs, manipulations and reuse: *fill-ups*, *fusing*, *patching* and *upcycling* (Figure 14.1), a classification based on the ways in which fragments or parts were used to modify the object.

#### ***Fill-ups***

*Fill-ups* are repairs where metal has been added to fill a hole or damage. It seems that small holes appeared during casting rather frequently when the liquid alloy did not successfully fill out the full cavity of the mould. A study of Danish period IV–V (1100–700 BCE) hoard finds found that this ‘casting defect’ was rather common (Kristiansen 2016 [1974]:131). Some visible holes were left unaltered and the object went on to be used anyway; this can be seen on tools such as axes (Nilsson 2008:29–33), but also on larger

**TABLE 14.1** The table shows some of the repaired LBA objects found in Sweden. Many of the hoards were discovered in the 19th century, and it is likely that fragments were sometimes neglected. SHM = Statens historiska museum; SLM = Södermanlands museum; UMF = Museum Gustavianum; KLM = Kalmar läns museum; VLM = Västmanland läns museum; OM = Östergötlands museum.

<i>No</i>	<i>Object type</i>	<i>Site, parish, province</i>	<i>Type of modification</i>	<i>Hoard</i>	<i>Reference</i>
1	Horse bit	Eskelhem, Eskelhems prästgård, Gotland	Fusing (new part)	In a mixed hoard with no/few fragmented objects	SHM 7994
2	Belt buckle	Öllöv, Grevic, Skåne	Fill-up	In a mixed hoard with no/few fragmented objects	SHM 12937
3	Belt buckle	Domta, Österunda, Uppland	Fill-up	In a mixed hoard with no/few fragmented objects	UMF 5690; Arwidsson 1939
4	Belt buckle	Slättäng, Vårkumla, Västergötland	Fill-up	In a mixed hoard with no/few fragmented objects	SHM 5316; Oldeberg 1943:214
5	Belt buckle	Vegestorp, Kareby, Bohuslän	Fusing	In a mixed hoard with no/few fragmented objects	SHM 845; Oldeberg 1943: 214; Baudou 1960:180, 260
6	Belt buckle	Nya Åsle, Åsle, Västergötland	Fill-up	In a mixed hoard with many fragmented objects	SHM 19748 (SHM 4127); Oldeberg 1934:11
7	Hanging vessel	Nya Åsle, Åsle, Västergötland	Fill-up (two reparies)	In a mixed hoard with many fragmented objects	SHM 4127; Oldeberg 1934:33–35
8	Cauldron	Hassel, Glanshammar, Närke	Patching (several mendings)	In a mixed hoard with no/few fragmented objects	SHM 21513; Gustawsson & Waldén 1937:66–70
9	Neck ring	Rud, By, Värmland	Fusing (hole)	In a mixed hoard with no/few fragmented objects	SHM 1056
10	Two neck rings	Svartarps gård, Åsle, Västergötland	Fusing (twisted)	In a mixed hoard with many fragmented objects	SHM 22470; Oldeberg 1934
11	Neck ring	?, ?, Bohuslän	Fusing (cast-on)	?	SHM 1270:455
12	Neck ring	Fageråkra, Veddige, Halland	Fusing	In a single type hoard with no/few fragmented objects	SHM 4228; Montelius 1917; no 1295
13	Neck ring/diadem	Långbro, Vårdinge, Södermanland	Patching (rivets and bronze sheet)	In a mixed hoard with no/few fragmented objects	SHM 2674

14	Neck ring	Spelviks Kyrka, Spelvik, Södermanland	Fusing	In a mixed hoard with no/few fragmented objects	SHM 813
15	Neck ring ( <i>wendelring</i> )	Around Falköping, ?, Västergötland	Fusing	?	SHM 7591:15
16	Neck ring ( <i>wendelring</i> )	Hökensåsén, Hubbo, Västmanland	Fusing (hole)	In a mixed hoard with no/few fragmented objects	VLM 3174; Arbman 1938:91
17	Neck ring ( <i>wendelring</i> )	Altuna, Börje, Uppland	Fusing (cast-on)	In a mixed hoard with no/few fragmented objects	SHM 16018; Ekholm 1921:katalog period VI.
18	Two neckrings ( <i>wendelring</i> )	?, Hårdshammar, Östergötland	Fusing (hole)	?	OM.C.000635; Nordén 1926:35
19	Neck ring ( <i>wendelring</i> )	Samsvik, Gladhammar, Småland	Fusing (cast-on)	?	Heynowski 2000:43, 315
20	Neck ring ( <i>wendelring</i> )	Hjälmarred, Allingsås, Västergötland	Fusing (hole)	In a mixed hoard with many fragmented objects	Hellgren & Lega 2021:21
21	Arm/foot ring ( <i>wulstring</i> )	Hjälmarred, Allingsås, Västergötland	Fusing (hole)	In a mixed hoard with many fragmented objects	Hellgren & Lega 2021:19
22	Ornamental disc	?, Hulterstad, Öland	Fusing (new part)	In a mixed hoard with no/few fragmented objects	SHM 9321; Hjärthner-Holdar 1993:137
23	Pin	Vallby, Veddige, Halland	Patching/Fusing (iron rivets and bronze sheet (now lost))	In a mixed hoard with no/few fragmented objects	SHM 6523
24	Spearhead	Hvarsta, Fröslunda, Uppland	Fill-up	?	Ekholm 1921:katalog period VI.
25	Spectacle fibula	Härnevi prästgård, Härnevi, Uppland	Fusing (two repairs)	In a mixed hoard with many fragmented objects	SHM 11635; Oldeberg 1933:180

(Continued)

**TABLE 14.1** (Continued)

<i>No</i>	<i>Object type</i>	<i>Site, parish, province</i>	<i>Type of modification</i>	<i>Hoard</i>	<i>Reference</i>
26	Spectacle fibula	Hjärpetan, Grava, Värmland	Fusing	In a mixed hoard with many fragmented objects	SHM 17093; Oldeberg 1928
27	Spectacle fibula	?, Skeby, Västergötland	Fusing	?	SHM 6753; Oldeberg 1936:164
28	Spectacle fibula	Senäte, Otterstad, Västergötland	Fusing	In a mixed hoard with no/few fragmented objects	SHM 1580; Oldeberg 1936:166
29	Spectacle fibula	Gunnarsmåla, Ålem, Småland	Fusing	?	KLM 000043; Oldeberg 1936:146, 169
30	Spectacle fibula	?, Västerlösa, Östergötland	Fusing	?	SHM 12799; Oldeberg 1936:172
31	Spectacle fibula	?, Kinda hd, Östergötland	Fusing	?	Oldeberg 1933:152, Montelius 1917:89; Nordén 1926:33
32	Sword (antenna sword)	Kråknäs, Svärta, Södermanland	Fusing	?	SLM 18011; Oldeberg 1942:80, 82–83; Hjärthner-Holdar 1993:151
33	Shields	Fröslunda, Sunnersberg, Västergötland	Patching	With several other shields	Klockhoff 1995
34	Fragment of bronze vessel	Eskelhem, Eskelhem prästgård, Gotland	Patching	In a mixed hoard with no/few fragmented objects	SHM 7994



**FIGURE 14.1** Examples of the four types of modifications detected in Late Bronze Age metalwork from Sweden and Denmark. Fill-up: a belt dome from Grevie, Skåne (SHM 12937; Photo from The Swedish History Museum (SHM), CC-BY 2.5 SE). Fusing: a spectacle fibula from Senäte, Västergötland (SHM 1580; Photo by Stina Svantesson, Västergötlands Museum). Patching: a neck ring from Långbo, Södermanland (SHM 2674; Photo from The SHM, CC BY 2.5 SE). Upcycling: a razor from Ebberup Mark Denmark (from Madsen 1872; see also Thrane 2013). The modifications are marked with arrows.

display items such as spectacle fibulas, spearheads and large belt ornaments (e.g. Oldeberg 1928, 1943:214; Arwidsson 1939).

Fill-ups were normally accomplished through ‘cast on’ (Ger. *überfangguss*; a method also used in other types of repairs; Drescher 1958). A new mould part was then modelled on or around the existing object to fill out the incomplete area (Skinner 2009; Nørgaard 2018:113). Fill-ups of rifts and small holes were probably often made directly in connection with production. A belt buckle with incised decoration on the mended area (SHM 5316) clearly shows a case where the fill-up was linked to the production process, between the stages of casting and decorating.

### *Fusing*

These are modifications where components or parts – from the same or different objects – were joined to (re)create a complete object. Fusing includes

repairs where specific components have been replaced, such as the horse bit of iron probably replacing an original bronze bit on a bronze harness from Eskelhem (SHM 7994; Hjärthner-Holdar 1993:138). It is a rather common type of repair and occurs on many different objects, such as spectacle fibulas, swords and neck rings.

Fusing is frequently seen on large brooches known as spectacle fibulas, especially where the two plates have been rejoined after a break. Sometimes, this appears to have been done immediately after casting (Oldeberg 1928, 1933). One fibula shows traces of being mended on two different occasions (KLM 000043; Oldeberg 1933:140, 168). There are also fibulas that have been modified by fusing plates originally belonging to two different objects (SHM 1580; Oldeberg 1933:141, 166–167; Melheim 2008:543; Figure 14.2).

There is fusing on swords where either the tang or the hilt have been removed from the blade and later re-attached. An example is seen on a sword of central European origin (SLM 18011), where the hilt and the blade have differing amounts and placements of rivet holes, suggesting they did not originally belong together (Oldeberg 1942:80, 82f; Hjärthner-Holdar 1993:151; see also Dumont 2022).

Another type of object where fusing is common are neck rings, and sometimes also arm rings and ankle rings. Rings have been modified by joining two broken halves together either by drilling small holes to attach some form of a string (e.g. Nordén 1926:35; Arbman 1938:91; Hellgren & Lega 2021:19, 21; for example, OM.C.000635; VLM 3174) or through ‘cast-on’ (e.g. Oldeberg 1943:215; Heynowski 2000:43; SHM 16018). Neck rings have also been ‘fused’ by twisting two ring halves together (Oldeberg 1943:112; Heynowski 2000:41; SHM 22470; Figure 14.2). Most of these modifications are highly visible and change the appearance of the ornament. Whether the parts were originally from the same or different rings cannot always be determined without more detailed, and possibly scientific, examinations. It might be that two broken rings were reassembled to contain half of each.

Several LBA *wendelrings* have been fused by joining parts through drilled or pierced holes (Nordén 1926:35; Arbman 1938:91; Heynowski 2000:41; Hellgren & Lega 2021:21; see Table 14.1). The holes indicate that the parts were, at least at some point in time, joined together with a string or a metal wire. As such repairs occur on several *wendelrings* distributed over a large area, this was evidently a common way of mending or re-attaching parts of broken rings of this type (Heynowski 2000:40–45; see also Jennings 2014:170). However, more discreet types of mending also figure in the material from Sweden, such as *wendelrings* mended through a ‘cast on’ (Oldeberg 1943:215; Heynowski 2000:43–45; SHM 16018). This type of repair can be difficult to detect and much more discreet than the examples with holes and joining strings (Figure 14.2).

### Patching

Patching is when small pieces or fragments have been added with rivets or ‘cast on’ to repair a broken object. This modification can be seen on pins and neck rings, but also on other objects, notably imported sheet bronze. As mentioned in the previous section, small fragments or patches have also been used in the fill-ups.

A conspicuous example of patching is seen on a bronze pin where two parts have been joined by drilling small holes and adding a patch (SHM 6523). As evident from rust marks on the object, this patch, now lost, was possibly joined on with iron rivets (Hjärthner-Holdar 1993:126–127).



**FIGURE 14.2** Three types of fused neck rings, with holes: Hårdshammar, Östergötland (OM. C 000635); cast-on: Altuna, Uppland (SHM 16018); and two fused by twisting two halves together: Svartarps gård, Åsle, Västergötland (SHM 22470; Photos from The SHM, CC-BY 2.5 SE; and Östergötlands Museum, CC-BY SA 4.0). The modifications are marked with arrows.

Patching can also be seen in some of the sheet bronze metalwork brought to Scandinavia from the Continent. It is unclear if these patches were added before or after the objects reached Scandinavia. Such repairs are, for example, visible on the rim of several of the Herzsprung-type shields found at Fröslunda (Klockhoff 1995:52). Patching where an added fragment covers a rift on the front upper rim can also be seen on a sheet bronze neck ring or ‘diadem’ (SHM 2674; see Figure 14.1).

Another clear example is the South European cauldron, with seven different repairs found and containing several other objects in the so-called Hassle hoard (SHM 21513). The bronze fragments used to patch the vessel vary in shape and thickness, thus probably being successively added over time. Patching is very common on cauldrons across Western and Central Europe; they were fragile and needed to be able to keep liquids and food (Gerloff 2010; Joy 2014). The repair work was clearly visible on these prestige objects and might also have added to their sense of age and patina.

### *Upcycling*

Upcycled items are fragments of old objects that have been repurposed and turned into something new and different. This practice has also been named *conversion* (Jennings 2014) and recycling (to differentiate from reuse, where the object’s shape is largely retained) (Caple 2010). However, in the context of bronze metalwork, recycling is mainly associated with remelting to cast new objects. We therefore choose to use the word upcycling, also known as creative reuse, a term that has gained popularity with environmentalism, circular economics and increasing interest in sustainable waste management and which signifies the practice of making new things out of used things or waste (e.g. Paras & Curteza 2018; for applied use in historical context, see Rous 2020). In the context of metalwork, upcycling, as conversion, can be defined as “the direct conversion of one object into another through cutting and reshaping” (Jennings 2014:163). Upcycled objects are often difficult to identify unless they have ornamentation or other morphological traces from their previous form.

Upcycling bits of old bronze objects into, for instance, arm rings, lancets, pins or awls was not unusual during the LBA (Baudou 1960:63; Thrane 2004; 2013; Kristiansen 2016 [1974]:145; Hornstrup 2018). There are several accounts of LBA arm rings made from larger neck rings (Baudou 1960:63). There are also cases where parts of arm or neck rings were reused to make very small arm rings with a diameter of around 3–4 cm, possibly designed for children (Kristiansen 2016 [1974]:144–145; see also examples in Thrane 2004).

LBA razors were sometimes made from fragments of other objects such as neck rings, hanging bowls and arm rings (Thrane 2013:445; Hornstrup

2018). There are also about 12 examples from LBA Scandinavia known so far where fragments of ‘imported’ bronze vessels have been upcycled into razors (Thrane 2013; Figure 14.1). The number is probably higher, since the origin of such fragments is only recognisable if they have ornamentation or include parts of the vessel rim. Sometimes the vessel decoration has been kept and respected/integrated into the razor, but this is not always the case (Thrane 2013). Henrik Thrane, who discussed this phenomenon in a 2013 paper, even identified three such fragment razors – from burials in northern Germany and on Danish Funen – that might originate from the same, decorated bronze vessel (Thrane 2013:449).

### **Summary of findings**

There are various ways in which LBA bronze objects were mended or modified by means of joining or adding parts to an ‘incomplete’ object. Some objects were probably mended just after being cast, while others were repaired at a later time after being accidentally or intentionally broken. There are also pieces that have been upcycled, meaning that a fragment was reworked into a new, different object. Modifications where parts or new materials were added occur on a wide range of objects, including more exclusive social valuables. These include *wendelrings*, shields, bronze vessels, spectacle fibulas, swords, belt buckles and large dress pins – object types presumably linked to prestige, social hierarchies and ritual display. The nature of the modifications on these display items indicates that the mending was rarely carried out with the intention of being discreet. Since this study is not exhaustive, more mended objects and types of modifications certainly remain undiscovered in assemblages of finds. For example, upcycled metalwork is likely to exist also in Sweden but awaits similar studies as those of Danish and German archaeological material (Thrane 2013; Hornstrup 2018).

### **Discussion: Manipulated objects – manipulated meanings**

These observations suggest that the attitude towards intact surfaces and the completeness of bronze metalwork was very different in the Scandinavian LBA than it is today. People who crafted and used these objects were less concerned about a smooth appearance. Some of the repairs are discreet, but many of the examples above are highly visible, and it often seems like little was done to hide them (see also Melheim 2008). Casting defects and mended items were evidently accepted or even appreciated, and the origin of upcycled cauldron pieces used as razors was sometimes evident from the remaining ornamentation or rims.

Visible repairs and alterations did not prevent the objects’ continued use or disqualify them from inclusion in depositions. Mended objects are

found in mixed hoards from dry-land contexts as well as in depositions in wet environments (Table 14.1) and were thus still considered appropriate for sacrificial offerings. Many of the repaired or modified objects, like spectacle fibulas and neck rings (particularly *wendelrings*), were probably objects of prestige worn very visibly (Kristiansen 1998:69; Melheim 2008:545). Here, modifications would have been apparent when worn, handled and seen. Some of the repairs show signs of wear, indicating that the objects remained in use after a modification (Nordén 1926:35). In addition, we find some items, such as the Hassle cauldron and the spectacle fibula from Ålem Parish, Småland, that have been mended more than once (KLM 000043; Oldeberg 1933). Little concern for visibility is also indicated by cases where metals with diverging colour nuances were used in repairs on LBA bronzes, such as iron rivets (Hjärthner-Holdar 1993; Sörman & Ojala 2022) or fill-ups with lead (Madsen 2009:85).

The visibility of the modifications could signal that repaired objects were considered ‘good enough’, for example, when objects were left with casting holes or were repaired with fill-ups immediately after casting. It also indicates that the value of LBA metalwork laid in other qualities than the visual impact of a perfect surface. One explanation for the tendency to keep imperfect casts and repaired objects in circulation could be that great importance was placed on the performance of the casting itself. LBA bronze casting was carried out at a variety of places and settings, including exposed locations within cult sites and large burial grounds interpreted as assembly sites, possibly meaning that the crafting of objects could take on the form of public events (Sörman 2018; see also Melheim 2015). LBA bronze castings as public rituals are further supported by the performative character of LBA casting in open hearths. The mythological dimensions indicated by finds of horse-shaped nozzles for bellows are one example; another is the nature of the products themselves, often markers of social and political status and presumably made in connection to important passage rituals (Sörman 2018). The significance of the process, timing and staging of the casting could explain why finished objects that turned out ‘flawed’ were kept and mended rather than remelted in a new try.

It has previously been suggested that visible repairs could indicate that the craftsperson responsible for the mending lacked the skills necessary to make an unobtrusive mending or to make a new object (Melheim 2008:545). Although this might sometimes be the case, most of the repairs from this period would still require some level of skill, and the object could have been melted and cast into something else. There are traces of widespread, non-centralised bronze artefact production during the LBA, including quite complicated objects cast locally in central Sweden (e.g. Oldeberg 1960; Sörman 2018), indicating that the availability of skill should not have been a problem. The origin of the metal recycled in new castings can also carry a meaning, and even when objects are melted down, their history can become part

of the new object (Caple 2010; see also Sörman this volume). This practice cannot be excluded for LBA Scandinavia, but this topic lies beyond the scope of this paper.

Although some of the repair work and modifications, such as patching up a leaking bronze cauldron, can be seen as repairs aiming to maintain the object's functionality, the mending can also be more than just a practical solution. While difficult to prove, examples of the fusing of parts from different objects, such as the spectacle brooches assembled from the discs of two different fibulas (Oldeberg 1933:141, 166–167; Melheim 2008:543), hint at a more complex reuse of fragments and parts than simple repairs and replacements. Fragments of bronze objects have been used to create new objects, not only by recasting but also by upcycling and by assembling parts of different objects. These repairs and modifications can be seen as part of the objects' cultural biography and indicate that objects chosen for manipulation were sometimes motivated by their special significance and use histories (Melheim 2008; Hornstrup 2018; Sörman this volume).

Some object types appear to have been manipulated more often than others, such as spectacle fibulas and *wendelrings*. This might simply reflect that certain object types are more fragile than others. Indeed, they are often broken in the place where the discs or rings are most easily broken off, partly due to weak points in their construction (Oldeberg 1933; Heynowski 2000:41). On the other hand, another reason behind the many repaired spectacle fibulas and neck rings might also be that these objects carried special meanings and values and therefore became subjected to manipulation more often. Anne Lene Melheim has pointed out the intentional asymmetry of many Nordic spectacle fibulas, suggesting that both the discs' initial design and various modifications, including fusing discs back together, could relate to a left-right symbolism in LBA cosmology (Melheim 2008). Breaking and recombining these symbols, reattaching separated halves, or taking parts representing different owners, generations, or meanings, could then have been a way to reinforce alliances between different people (Melheim 2008) or more generally to manipulate their 'power'.

The frequency of the fusions of neck ring halves, spectacle fibula discs and the blades and handles of swords hints at the specific *fragmentation quality* of various objects. We believe that it is reasonable to suggest that practices of fragmentation, dismantling and reassembly may develop differently for 'partible' and 'composite' pieces of metalwork (see also Chittock this volume). This can be illustrated by looking at swords and spectacle fibulas on the one hand and neck rings on the other. Most swords are constructed as composite objects, where the handle and blade are made separately (possibly also in different materials) and then joined. There are numerous European examples of Bronze Age swords and daggers where blade and handle have been treated differently, for example, in separate depositions (e.g. Knight 2022:143–144)

or components of different origins joined together in new combinations (e.g. Kristiansen 2002; Dumont 2022). The same fragmentation quality can be seen in the way Nordic LBA spectacle fibulas were constructed, joined and rejoined, consisting of two readily breakable halves.

Neck rings, on the other hand, are made in one piece, and breaking them in two creates a distinct separation of a whole lacking obvious components. Manipulating and rejoining pieces of fragmented neck rings could therefore, we argue, implicate something else. Composite versus fragmented objects implicate different possibilities of enchainments as an outcome of repairs and additions (see also Chittock this volume). Composite objects allow for parts to be replaced and for different people to contribute to the object's completion (Chapman 2000:40, 222). It also creates the opportunity to enchain various people and histories into one object during repair work (Chapman 2000; Verger 2019; Chittock 2020). For 'partible' but non-composite objects, on the other hand, the repairs or modifications may stand out even more clearly, as one could argue that a 'solid' object is more obviously or drastically broken than a composite object. This quality offers a striking way of creating material and visual effects that add extra dimensions to the object, such as two neck ring parts visibly linked together by a string. We can imagine that the histories, values and powers attached to these objects could be accumulated and combined into new physical forms.

### Further questions

In this chapter, we have focused on the 'second life' of metalwork fragments as they become reintegrated into a repaired object or upcycled into new forms. The material demonstrates various forms of LBA manipulation and hints at the value placed on modifications, as indicated by their visibility and frequency. Other types of modifications are probably still hidden, undiscovered, in the LBA metalwork. The archaeological material demonstrates the different ways in which LBA bronze objects were 'partible' and could be reassembled in different constellations, of which only some have been discussed here. Future studies should develop methods for distinguishing between deliberate and accidental breaks and look further into the sets and levels of skill needed in order to carry out these modifications. Another avenue for future research lies in the identification of pieces from the same objects ending up in different places, such as when investigating the origins of upcycled razors from similar vessel types or examining halves of fused neck rings to see if they originally belonged to the same or different rings. By scratching the surface of the 'perfect' metalwork shown in corpus works and reconstruction drawings, post-production manipulations and the reuse of broken pieces will continue to be a rich source for understanding how these bronze objects were approached, valued and used in LBA society.

## Acknowledgements

This research was supported by the Berit Wallenberg Foundation (BWS 2019.0051 and BWS 2020.0042). A. Sörman also had the benefit of support from the Wenner-Gren Foundations (WGF2021-0006) during parts of this work.

## References

- Arbman, H. 1938. Mälardalen som kulturcentrum under yngsta bronsåldern. In: H. Nordling-Christiansen & P. V. Globe (eds) *Winther-Festschrift*. Copenhagen: Munksgaard, 83–108.
- Arwidsson, G. 1939. Bronsåldersfyndet från Domta vad i Österunda socken. *Upplands fornminnesförenings tidskrift* XLVI(2): 65–80.
- Baudou, E. 1960. *Die regionale und chronologische Einteilung der jüngeren Bronzezeit im Nordischen Kreis*. Stockholm: Almqvist & Wiksell.
- Bradley, R. 1990. *The passage of arms: an archaeological analysis of prehistoric hoard and votive deposits*. Cambridge: Cambridge University Press.
- Brück, J. 2016. Hoards, fragmentation and exchange in the European Bronze Age. In: S. Hansen et al. (eds) *Raum, Gabe und Erinnerung: Weihgaben und Heiligtümer in prähistorischen und antiken Gesellschaften*. Berlin: Edition Topoi, 75–92.
- Caple, C. 2010. Ancestor artefacts – ancestor materials. *Oxford Journal of Archaeology* 29(3): 305–318. <https://doi.org/10.1111/j.1468-0092.2010.00350.x>
- Chapman, J. 2000. *Fragmentation in archaeology: people, places, and broken objects in the prehistory of south-eastern Europe*. London: Routledge. <https://doi.org/10.4324/9780203759431>
- Chapman, J. & Gaydarska, B. 2007. *Parts and wholes: fragmentation in prehistoric context*. Oxford: Oxbow Books.
- Chittock, H. 2020. Pattern as patina: Iron Age ‘kintsugi’ from East Yorkshire. In: L.-M. Back Danielsson & A.M. Jones (eds) *Images in the making: art, process, archaeology*. Manchester: Manchester University Press, 149–167.
- . 2021. *Arts and crafts in Iron Age East Yorkshire: a holistic approach to pattern and purpose, c. 400BC–AD100*. Oxford: BAR Publishing.
- Dooijes, R. & Nieuwenhuys, O.P. 2007. Ancient repairs: techniques and social meaning. In: M. Bentz & U. Kästner (eds) *Konservieren oder Restaurieren, die Restaurierung Griechischer Vasen von der Antike bis Heute* (3rd suppl. to the CVA Germany). Munich: Beck, 15–20.
- Drescher, H. 1958. *Der Überfangguss. Ein Beitrag zur vorgeschichtlichen Metaltechnik*. Mainz: Verlag des Römisch-Germanischen Zentralmuseums.
- Dumont, L. 2022. Quelques réflexions sur La réparation et la réutilisation des objets métalliques à l’âge du Bronze : aspects techniques et culturels. In: G. Bernasconi et al. (eds) *Les réparations dans l’histoire : cultures techniques et savoir-faire dans la longue durée*. Paris: Presses des Mines, 481–493.
- Ekholm, G. 1921. *Studier i Upplands bebyggelsehistoria II. Bronsåldern*. Uppsala: Uppsala universitet.
- Fontijn, D. 2019. *Economies of destruction: how the systematic destruction of valuables created value in Bronze Age Europe, c. 2300–500 BC*. Abingdon, Oxon: Routledge. <https://doi.org/10.4324/9781315109879>

- Gerloff, S. 2010. *Atlantic cauldrons and buckets of the Late Bronze and Early Iron Ages in Western Europe: with a review of comparable vessels from Central Europe and Italy*. Stuttgart: Franz Steiner Verlag.
- Gustawsson, K.A. & Waldén, B. 1937. Hasslefyndet. *Meddelanden från Föreningen Örebro läns museum* 12, 61–72.
- Hellgren, M. & Lega, J. 2021. *Bronsdepån i Hjälmed – efterundersökning av en fyndplats*. Vänersborg: Västra Götalandsregionen.
- Heynowski, R. 2000. *Die Wendelringe der späten Bronze- und der frühen Eisenzeit*. Bonn: Habelt.
- Hjärthner-Holdar, E. 1993. Järnets och järnmetallurgins introduktion i Sverige. Uppsala: Uppsala University.
- Horn, C. & Karck, T. 2019. Weapon and tool use during the Nordic Bronze Age. *Danish Journal of Archaeology* 8: 1–20. <https://doi.org/10.7146/dja.v8i0.111834>
- Hornstrup, M.K. 2018. Fragmenter, omdannede genstande og social status i yngre bronzealder. In: S. Boddum & N. Terkildsen (eds) *Status og samfundsstruktur i yngre bronzealders kulturlandskab*. Viborg: Viborg Museum, 101–113.
- Jantzen, D. 2008. *Quellen zur Metallverarbeitung im Nordischen Kreis der Bronzezeit*. Stuttgart: Franz Steiner Verlag.
- Jennings, B. 2014. Repair, recycle or re-use? creating mnemonic devices through the modification of object biographies during the Late Bronze Age in Switzerland. *Cambridge Archaeological Journal* 24(1): 163–176. <https://doi.org/10.1017/S0959774314000055>
- Jervis, B. & Kyle, A. (eds) 2012. *Make-do and mend: archaeologies of compromise, repair and reuse*. Oxford: Archaeopress.
- Joy, J. 2014. ‘Fire Burn and Cauldron Bubble’: Iron Age and Early Roman cauldrons of Britain and Ireland. *Proceedings of the Prehistoric Society* 80: 327–362. <https://doi.org/10.1017/ppr.2014.7>
- Klockhoff, M. 1995. Sköldarna ur konservatorns synvinkel. In: P. Jankavs (ed.) *Långt borta och nära. Gudaoffer och vardagsting från bronsåldern*. Skara: Skaraborgs länsmuseum, 33–57.
- Knight, M.G. 2022. *Fragments of the Bronze Age: the destruction and deposition of metalwork in south-west Britain and its wider context*. Oxford & Philadelphia: Oxbow books.
- Kristiansen, K. 1974. Glerupfundet. Et depotfund med kvindesmykker fra bronzealderens femte periode. *Hikuin* 1: 7–38.
- . 1998. *Europe before history*. Cambridge: Cambridge Univ. Press.
- . 2002. The tale of the sword – swords and swordfighters in Bronze Age Europe. *Oxford Journal of Archaeology* 21(4): 319–332.
- . 2016 [1974]. *En analyse af yngre bronzealders depotfund (Periode IV–V) i Danmark: kildekritik, kronologi og tolkning*. Gothenburg/Academia.edu.
- Levy, J.E. 1982. *Social and religious organization in Bronze Age Denmark: an analysis of ritual hoard finds*. Oxford: BAR Publishing.
- . 1991. Metalworking technology and craft specialization in Bronze Age Denmark. *Archaeomaterials* 5(1): 55–74.
- Madsen, A.P. 1872. *Afbildninger af danske oldsager og mindesmaerker. Bronzealderen*. Copenhagen: Gyldendalske.
- Madsen, B.H. 2009. Repairs in antiquity illustrated by examples from the prehistory of Denmark. In: J. Ambers et al. (eds) *Holding it all together: ancient and modern approaches to joining, repair and consolidation*. London: Archetype Publications, 83–88.

- Martin, T. 2012. Riveting biographies: the theoretical implications of early Anglo-Saxon brooch repair, customisation and use-adaptation. In: B. Jervis & A. Kyle (eds) *Make-do and mend: archaeologies of compromise, repair and reuse*. Oxford: Archaeopress, 53–65.
- Melheim, L. 2008. Right and left. directions in Bronze Age cosmology seen through a pair of spectacle-fibulas. In: C. Konstantinos et al. (eds) *Facets of archeology: essays in honour of Lotte Hedeager on her 60th birthday*. Oslo: Unipub, 539–554.
- . 2015. Støpeplasser og handelsplasser – to sider av samme sak? In: S. Boddum et al. (eds) *Bronzestøbning i yngre bronzealders lokale kulturlandskab*. Viborg & Holstebro: Viborg museum & Holstebro museum, 15–30.
- Montelius, O. 1917. *Minnen från vår forntid: 1. Stenåldern och bronsåldern*. Stockholm: P.A. Nordstedt & Söner.
- Nilsson, A. 2008. *Gjutfel och dålig ornamentik: om bronsgjutares hantverksskicklighet under skandinavisk bronsålder*. Unpublished master thesis. Department of Archaeology and Ancient History, Lund University.
- Nordén, A. 1926. Östergötlands bronsålder. Linköping: Henric Carlssons bokhandels förlag.
- Nørgaard, H.W. 2018. *Bronze Age metalwork: techniques and traditions in the Nordic Bronze Age 1500–1100 BC*. Oxford: Archaeopress Archaeology. <https://doi.org/10.2307/j.ctvndv72s>
- Oldeberg, A. 1927. Ett smedfynd i Ystad från yngre bronsåldern. *Fornvännen* 22: 107–121.
- . 1928. Ett bronsåldersfynd från Hjärpetan i Värmland. *Fornvännen* 23: 321–345.
- . 1933. *Det nordiska bronsåldersspännets historia med särskild hänsyn till dess gjuttekniska utformning i Sverige*. Stockholm: Kungl. Vitterhets historie och antikvitets akademien.
- . 1934. Två bronsåldersfynd från Åsle socken i Västergötland. *Västergötlands fornminnesförenings tidskrift* 4(7–8): 9–42.
- . 1942. *Metallteknik under förhistorisk tid I*. Lund: Håkan Ohlssons boktryckeri.
- . 1943. *Metallteknik under förhistorisk tid II*. Lund: Håkan Ohlssons boktryckeri.
- . 1960. *Skälbyfyndet: en boplatzlämning från den yngre bronsåldern*. Stockholm: Kungl. vitterhets historie och antikvitets akademien.
- Paras, M.K. & Curteza, A. 2018. Revisiting upcycling phenomena: a concept in clothing industry. *Research Journal of Textile and Apparel* 22(1): 46–58. <https://doi.org/10.1108/RJTA-03-2017-0011>
- Rous, S.A. 2020. Upcycling as a new methodological approach to reuse in Greek architecture. In: P. Sapirstein (ed.) *New directions and paradigms for the study of Greek architecture: interdisciplinary dialogues in the field*. Leiden: Brill, 215–228. [https://doi.org/10.1163/9789004416659\\_015](https://doi.org/10.1163/9789004416659_015)
- Rundkvist, M. 2015. *In the landscape and between worlds: Bronze Age deposition sites around Lake Mälaren and Hjälmarén in Sweden*. Umeå: Umeå University.
- Skinner, L. 2009. Bronze Age metalwork from central Norway: some examples of ancient and modern repair. In: J. Ambers et al. (eds) *Holding it all together: ancient and modern approaches to joining, repair and consolidation*. London: Archetype Books, 31–34.

- Sørensen, M.L.S. 1987. Material order and cultural classification: the role of bronze objects in the transition from Bronze Age to Iron Age in Scandinavia. In: I. Hodder (ed.) *The archaeology of contextual meanings*. Cambridge: Cambridge Univ. Press, 90–101.
- Sörman, A. 2018. *Gjutningens arenor: metallhantverkets rumsliga, sociala och politiska organisation i södra Skandinavien under bronsåldern*. Stockholm: Stockholm University.
- Sörman, A. & Ojala, K. 2022. Iron in the Nordic Bronze Age and early Pre-Roman Iron Age – visibility, colour contrasts and celestial associations. *Norwegian Archaeological Review* 55(2): 107–139. <https://doi.org/10.1080/00293652.2022.2068157>
- Swift, E. 2012. Object biography, re-use and recycling in the Late to Post-Roman transition period and beyond: rings made from Romano-British bracelets. *Britannia* 43: 167–215. <https://doi.org/10.1017/S0068113X12000281>
- Thrane, H. 2004. *Fyns yngre bronsaldergrave*, Bind 1 and 2. Odense: Odense Bys Museer.
- . 2013. Scrap metal razors: Late Bronze Age razors made of scrap metal – another source for the study of imported bronze vessels. In: I. Heske et al. (eds) *“Landschaft, Besiedlung und Siedlung”: archäologische Studien im nordeuropäischen Kontext: Festschrift für Karl-Heinz Willroth zu seinem 65. Geburtstag*. Neumünster: Wachholtz, 445–453.
- Verger, S. 2019. Manipulation des objets et recomposition du passé dans les sociétés de l’âge du Fer. In: R. Gollosetti (ed.) *Mémoires de l’âge du Fer: Effacer ou réécrire le passé*. Paris: Hermann, 237–286. <https://doi.org/10.3917/herm.golos.2019.01.0238>
- Willmott, H. 2001. A group of 17th-century glass goblets with restored stems: considering the archaeology of repair. *Post-Medieval Archaeology* 35(1): 96–105. <https://doi.org/10.1179/pma.2001.004>

# 15

## SELECTIVE FRAGMENTATION

Exploring the treatment of metalwork across time and space in Bronze Age Britain

*Matthew G. Knight*

### **Selective deposition and selective fragmentation**

The deposition of Bronze Age (BA) artefacts, particularly metalwork, is a widely studied phenomenon. Thousands of weapons, tools, ornaments, ingots and casting waste were treated in a variety of ways and buried in various contexts across Europe during the period 2400–600 BCE (Bradley 1998 [1990]; Fontijn 2019). Some ended up in graves with the deceased, others were buried in pits, ditches and postholes within settlements; much more has been recovered as single finds and in hoards, placed in ‘natural’ places within landscapes, such as in rivers and bogs and on hilltops. How we might approach these practices and how we might interpret different social actions has been a key focus of metalwork depositional studies.

In 1988, Stuart Needham published his seminal paper on the ‘selective deposition’ of Early Bronze Age (EBA) metalwork in Britain, which highlighted how different object forms were, as a rule, treated differently at the point of deposition. Axeheads, for instance, were often deposited in isolation or occasionally in hoards but rarely in association with human burials; daggers and ornaments, conversely, were commonly associated with the dead in funerary contexts and monuments. This suggests certain governing ideologies and structures behind depositional practices relating to metalwork. Since Needham’s paper, the concept of selective deposition has been integral to understanding BA metalwork practices.

Similarly, David Fontijn’s (2002) work on BA metalwork deposition in the southern Netherlands emphasised and expanded how we might view deposition as a structured practice that can highlight relationships between people, landscapes and objects. Understanding the histories of objects as well as the

specific nature of landscapes and what these meant to BA communities is fundamental to how we can conceptualise the function of deposition. Fontijn has expanded on this recently, outlining principles that lay behind identifying and understanding selective deposition and describing selective deposition as ‘the right way to act’ (Fontijn 2019:26–29).

This includes the right appearance for objects, the right selection for association, the right treatment, the right ordering in how they are placed in the ground and the right location for deposition. Collectively, these concepts tie into and reveal individual decisions made at the point of deposition as well as broader structures and ideologies at play. While it is the collective nature of these elements that reveals to us meaning in the past, each is multi-faceted and can also be interrogated individually and explored further. In this paper, I want to specifically address the ‘right’ treatment of an object. The right treatment can refer to several aspects relating to the object’s history (e.g. how it was treated during ‘life’) as well as how it was treated prior to and at the point of deposition and where it is deposited. For many objects across BA Europe, the right way to treat them was to leave them complete with other elements of structure and ordering incorporated into the deposition (e.g. arrangement and containment, marking the findspot, etc.). However, over time, the deliberate damage and fragmentation of objects became more common, occurring infrequently during the EBA, more often in the Middle Bronze Age (MBA) and by the Late Bronze Age (LBA), many thousands of objects were deliberately damaged before they were consigned to the ground, either singly, at settlements or accumulated in hoards (Knight 2022).

Studies of deliberate destruction often focus on the large and numerous fragmentary hoards of the LBA (e.g. Maraszek 2006), but instances occur throughout the BA and in almost every context. Within a given assemblage, certain types of objects may show signs of destruction while others are excluded, or alternatively, we may observe patterns across an object category spanning a wider area.

In this paper, I will explore these phenomena and develop the concept of ‘selective fragmentation’ under the umbrella of selective deposition and the ‘right’ way to treat objects. Damaging or fragmenting an object was a separate event from the deposition of the object (though sometimes closely related) and included its own range of decisions, notably selecting which objects to damage, the method for achieving intentional damage and the extent to which objects were fragmented. These decisions were made in the context of wider belief systems as well as specific relationships between people, objects and landscapes. By focusing on single finds and hoards from Britain as well as damaged artefacts from other contexts, fragmentation can provide us with clues to localised identities, regionalised practices and connections through wider concepts.

### What are we looking for?

In any study of damaged objects, we must establish that the damage is (a) ancient and (b) intentional. To achieve this, one must pay detailed attention to the object's condition and history, as well as draw on wear analysis, experimental archaeology and material science (Knight 2020, 2022:15–44). This holistic approach is essential for an accurate interpretation. Destroying an object renders it unusable for its original function and indicators of metalwork destruction include bending, burning, breaking, crushing, notching, twisting, plugging sockets and stabbing (Knight 2020). For the purpose of this paper, we need to consider:

- Are there patterns of damage across similar objects and across different objects? Do these indicate places of inherent weakness or the selection of fragmenting objects in certain ways?
- Is there evidence for the process of fragmentation? Is there associated damage (e.g. bending, hammering or cracking)?
- Were pieces and fragments selected for deposition? Do we see recurring parts of objects included in depositions?
- What evidence is there for *when* the fragmentation occurred? Was the object damaged at the point of deposition or some time before?

We cannot answer these questions for every object, but through these questions we can recognise elements of selective practice, which can then tie into other principles behind selective deposition and enhance our understanding of the people and meaning behind depositions.

### Fragmentation as a regional practice: Early Bronze Age axeheads in Scotland

Let us start our investigation with the deposition of EBA bronze axeheads in Britain at the end of the second millennium BCE, c. 2150–1950 BCE. At this time, axeheads were overwhelmingly deposited as single finds and in complete condition (Needham 1983, 1988).

However, in central and north-east Scotland, EBA axeheads were occasionally deliberately fragmented prior to deposition, and sometimes these were collected into hoards. The Hill of Finglenny hoard (Aberdeenshire) highlights this well (Figure 15.1a). Discovered in 1947, the Finglenny hoard comprised eight broadly similar axeheads, each with a tin-enriched surface and all showing differential signs of use and wear (Stevenson 1948; Crellin 2020:218–219). The variable signs of use led Needham (2004:222) to suggest these axes may have been gathered over an extended period. Three of the eight axeheads were deliberately broken into two pieces, some with chisel

marks indicating the method of fragmentation. The sharp, straight fractures on these pieces are unworn and may have been done shortly before or even at the point of deposition.

Other deliberately damaged axeheads, broken into two pieces, have been recovered as single finds and in hoards from Scotland (Figure 15.1b; Coles 1969:33). These were, in most cases, deliberately split across the thickest part of each axehead. This was probably achieved by heating the axeheads before striking with a blunt object and/or chisel (see Knight 2019), a coordinated action requiring technical and material knowledge operating within a specific social context. The sharp breaks on the Finglenny axeheads suggest that someone with material knowledge undertook this. By contrast, an example from Abdie (Fife) is covered in hammering marks and is bent and cracked, suggesting that the person who did this wanted to break the axehead in half according to wider ideas but lacked the material knowledge to know how to achieve it (Figure 15.1c; Knight 2020:61–63).

Where information is known, these axeheads were often part of structured deposits or placed in relation to significant places (Cowie 2004). The Finglenny hoard, for instance, was buried under a stone on the slope of a hill overlooking a Neolithic henge. A hoard from Colleonard Farm (Banffshire) included seven decorated axeheads deposited with their cutting edges

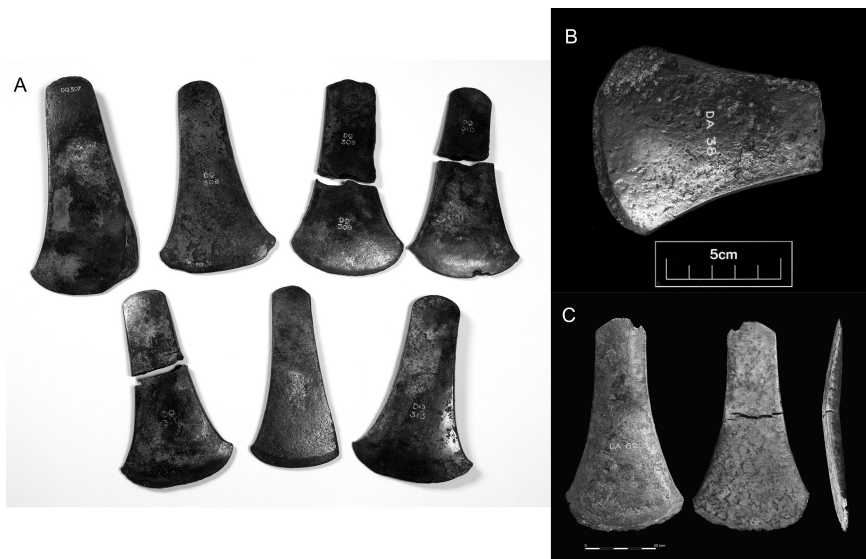

**FIGURE 15.1** A selection of deliberately damaged flat axeheads from Scotland. (a) The Hill of Finglenny hoard, Aberdeenshire; (b) an axehead from a cairn at Balnoon, Banffshire; (c) an axehead from Abdie, Fife (© National Museums Scotland).

upwards in a ceramic vessel packed between two stones, close to a stone circle (Piggott & Stewart 1958:GB.29; Cowie 2004:258–260); two of these axeheads were broken. Many of these axeheads were deliberately deposited without their hafts, and even when broken, all pieces of the axeheads were usually included, suggesting that fragmentation was a formal part of preparing some axeheads for deposition. Some axeheads needed to be broken, but even when broken, they were often kept ‘complete’, as both pieces were included in the deposition. This contrasts with elsewhere in Britain and Ireland, where single finds were most common, hoards were rarer, and objects were deposited intact. From c. 1700 BCE, hoarding became more common, but axeheads and other objects accumulated for deposition were still generally complete (Needham 1988). Following Fontijn (2019:35), these axe depositions may thus be termed ‘convention breakers’, examples of events that did not conform with usual practices and highlight significant social actions.

Deliberately destroyed EBA objects were more commonly associated with burials. Daggers, pots and ornaments were occasionally damaged before burial or burned with cremations (Woodward 2002; Brück 2004; Knight 2022). Bodies, too, were sometimes fragmented after death (Booth & Brück 2020; Brück this volume). These fragmentation processes may have been part of the symbolic nature of death – objects literally being ‘killed’ and bodies taken apart – but the resulting pieces allowed artefacts and people to continue to be curated and circulated, connecting people through fragments (Chapman 2000). If we consider that deliberate breakage in the EBA was occasionally linked with death, we may suggest that breaking axeheads was also related to death. Perhaps the owner(s) of the axeheads died, and thus the axeheads were broken. If some groups of axeheads were accumulated over time, this would explain why some axeheads were broken while others were kept complete. Nonetheless, BA cultural conventions dictated that axeheads stayed outside funerary contexts and were thus buried as single and/or hoarded finds. The practices undertaken in north-east Scotland represent a localised manifestation and expression of how to treat and bury metalwork at a specific time, breaking with wider practices. There was a conscious decision to break some axeheads and not others, with metalwork deposits connected to an aspect of regional identity.

### **Fragmentation as relational choice: Middle Bronze Age ornaments in southern Britain**

This relationship between people and the decision to fragment objects can be explored further through the ornaments and ornament hoards deposited during the MBA (c.1400–1150 BCE), particularly in southern Britain. Weapons and tools are also occasionally featured in these deposits, but we shall focus

primarily on ornaments here. By their very nature, ornaments have personal associations; they are worn close to the body and can express and confirm elements of an individual's identity. These are often inalienable objects, so intrinsically connected with a person that that association is hard to undo. During the MBA, bronze and gold ornaments, including bracelets, torcs, pins and rings, were deposited (complete and incomplete, often showing signs of wear) as single finds and in hoards, though rarely in settlement contexts or with human burials (Roberts 2007). We see varied approaches to the treatment and deposition of objects during this period; some were deposited complete and undamaged, while others were bent, crushed or cut (Wilkin 2017). In Neil Wilkin's (2017) study of ornament hoards, about 30% showed some evidence for deliberate manipulation and structured arrangement. In addition to these hoards, we can add a range of single finds that show signs of deliberate treatment.

During the period 1275–1150 BCE, gold torcs, for instance, were predominantly deposited complete and undamaged, either as single finds or in hoards in dryland and wet contexts (Eogan 1994:127–129; Roberts 2007; Murgia et al. 2014), though they were occasionally also coiled, crushed, rolled, cut or melted (Wilkin 2017:29–30; Knight 2022:77–78). Torcs required great skill to produce and were significant sacrifices of wealth and material when deposited. Some complete torcs were coiled for deposition, distorting the form of the torc as an act of decommissioning (Ramsey 2013), though they may have also been coiled for wrapping around the arm. A coiled example from the Burton hoard (Wrexham) was perhaps stored with other gold ornaments and bronze tools in a ceramic vessel (Gwilt et al. 2007). At Llanwrthl (Brecknockshire), four coiled torcs were buried one pair above the other, separated by a small stone and all overlaid by a large stone and a heap of smaller stones (Savory 1958:52–54).

Coiling was part of the structure of these deposits. Notably, these coiled examples remained complete and could be uncoiled; this was reversible damage, be it for storage, functionality or symbolic deformation. Three coiled fragments of at least two torcs from Woodham Walter (Essex) paint a different picture (Meeks & Varndell 1994). Found with three complete bracelets, each torc was deliberately cut at one end, flattened at the opposite end and conformed to an almost identical size and weight. These were perhaps coiled and cut by a metalworker and intended for recycling. Two substantial hoards from Cirencester (Gloucestershire) (Needham 2007) and Fittleworth (West Sussex) (British Museum acc. no. 1996, 0902) likewise contained deliberately bent, coiled and cut gold torcs, bracelets and rings; these may have also involved a metalworker. Cutting these ornaments required particular tools and equipment that may have been the reserve of a goldsmith, though we should be wary of a purely functionalist interpretation of these deposits as they each contained complete finds too.

Numerous single finds of bent and/or fragmented gold torcs and bracelets recovered while metal-detecting and reported through the Portable Antiquities Scheme also display signs of cutting and reduction processes (Murgia et al. 2014:360; Knight 2022:77–78). These isolated finds have typically been regarded as casual losses, which indeed they might be, but by recognising the intentionality behind their treatment, we can set them in the wider context of other comparable manipulated finds in hoards and contrast this with the decision to leave some torcs and gold ornaments complete.

Bronze ornaments, too, saw a range of treatments and associations in deposition, particularly when deposited as part of larger groups between 1400–1275 BCE. The Bix hoard (Oxfordshire) contained 19 objects in c. 85 pieces buried in a ceramic vessel, including a fragmented rapier in seven pieces, a heavily worn dagger or dirk, two worn razors, a complete bracelet and fragments of pins, torcs and bracelets (Figure 15.2; Byard 2015, 2016:239–240). Although much of this hoard was plough-dispersed, excavation revealed worn and damaged objects *in situ* within the remains of the vessel (Byard 2016:240), suggesting this was the intended condition of the objects when deposited. Nine further fragments have been discovered from the same site since this initial investigation. The extent of the fragmentation,

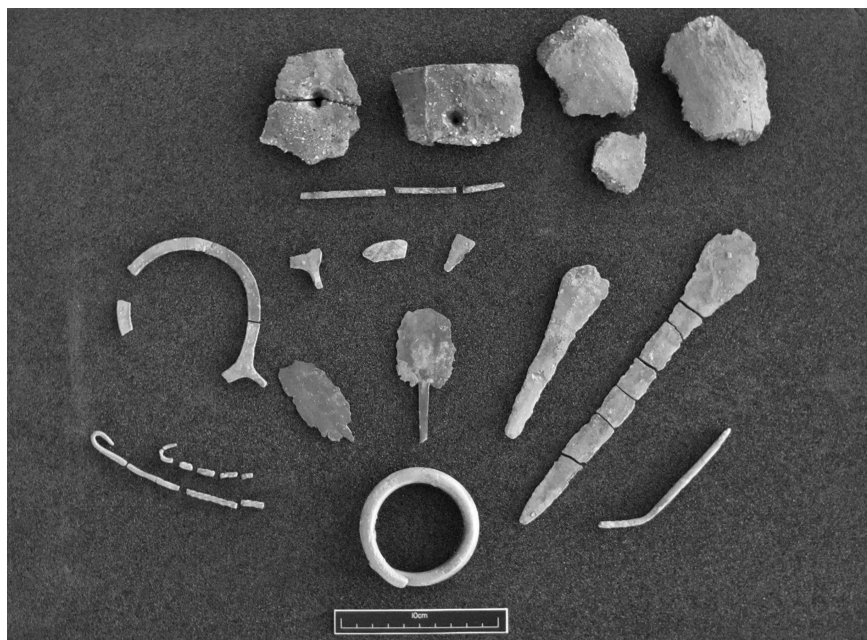

FIGURE 15.2 A portion of the Bix hoard, Oxfordshire (PAS BERK-456EE1) (© Oxfordshire County Council, CC BY 2.0).

particularly of the rapier in seven pieces but also the ornaments, is greater than one would expect from plough damage, especially considering some objects remained undamaged. Further study of this hoard would help better understand the nature and extent of the objects. The antiquity of breaks, for instance, would be revealed through a study of the patina and marks on the surface, which might correlate to ancient hammer/chisel blows.

The Taunton Union Workhouse hoard (Somerset), comprised approximately forty tools and ornaments deposited in a river valley (Smith 1959:GB.43; Knight 2022:66–76). Sixteen objects were intentionally damaged, including a broken spearhead, a fragmented bracelet and 11 bent and broken pins (Knight 2022:66–70). However, the ‘tools’ in the hoard, including an axehead, hammer, two sickles and 11 palstaves, were either complete or damaged through use, though some may have been burned.

What motivated this range of treatments? Why were some ornaments left complete while others were manipulated and fragmented? The range of selective treatments defies a single rationale, probably reflecting individual or communal choices in relation to particular situations or circumstances. This is unsurprising if we consider the inalienable nature of ornaments, often associated with specific people; their removal from the person for placement in deposition may have necessitated different situation-appropriate decisions. This was perhaps influenced by the previous trajectories and associations of objects, as suggested by their worn nature. Sometimes people needed to fragment or deform these ornaments, and these processes allowed the transformation of objects into suitable states for deposition, severing ties between objects and the associated person(s). Burying them in natural places was an important part of this. Robert Johnston (2021:102–105) argues that people deposited objects as acts of gift exchange with the landscape (cf. Strathern 1988) and that many of these depositions involving ornaments, as well as tools and weapons, were intimate and carefully considered occasions to establish relations between people, objects and landscapes. Preparing the deposition may have involved individuals or communities and required a range of activities, such as collecting objects and seeking material specialists to undertake certain tasks, including coiling or fragmenting torcs. Depositions were undertaken in relation to certain events, perhaps marriages or alliance pacts (Needham 2001), and fragmentation was part of the nuances of different occasions. Through the processes associated with deposition, ornaments ceased to be linked with a single person, perhaps deconstructing identities (Fontijn 2002:239, 244), and became part of a wider set of relationships. However, it is striking that ornaments were rarely deposited at MBA settlements or burials (Roberts 2007:147), which suggests a selective exclusion from certain social spheres. Much like flat axeheads, we might conclude that while people knew that ornaments should be primarily deposited as single finds or hoards in the landscape, there were fewer social restrictions

on how they might be treated at the point of deposition. This remained a choice.

### **Fragmentation as an event: Late Bronze Age weapons and weapon hoards**

The ornament hoards mentioned above occasionally included weapons, which often showed signs of deliberate destruction. York's (2002) study of metalwork from the River Thames highlighted that deliberately damaged weapons became more common from the MBA onward. The deliberate destruction and deposition of weaponry, notably swords and spearheads, peaked around 1100–900 BCE in Britain, when large numbers of swords and spearheads were deliberately burnt, bent and broken and immersed in a range of watery locations, such as rivers, bogs, lakes and marshes (Coombs 1975; Mörtz 2018). Other objects, such as vessels, axes and metal waste, rarely featured in these deposits (Mörtz 2018). The selection and treatment of objects was intimately linked with the types of places chosen and this applied as much to single finds and small groups as it did to large accumulations of weapons. Moreover, this was not the reduction of weapons to small pieces for recasting but sometimes seemed to be ecstatic events of destruction (Nebelsick 2000), with swords twisted and bent and spearheads crushed.

Several large hoards include evidence of fire damage, with swords and spearheads warped and melted from exposure to excessive heat. Striking examples come from Wilburton (Cambridgeshire), Duddingston Loch (Edinburgh) and Peelhill Farm (South Lanarkshire) (Evans 1884; Callander 1922; Mörtz et al. 2021). In these instances, we can conceptualise events involving large flaming pyres where people gathered weapons and threw them onto the fire; these were designed to create a performance through practice that became embedded in social memory (Knight 2022:149, 159–160). Destruction experiments and microstructural analyses have revealed that even where fire damage is not macroscopically visible, objects were heated before fragmentation (Knight 2019; Bridgford & Northover 2020). Therefore, such dramatic events may have been more common than previously recognised. Barbed spearheads from the Bloody Pool hoard (Devon) were probably heated to about 500–600 degrees Celsius, i.e., well below the melting point of bronze, and then struck with a blunt object to split the spearheads in two or three pieces (Figure 15.3; Knight 2019). Similar sharp straight fractures can be observed on spearheads from other contemporaneous single finds recovered from wet contexts as well as hoards (e.g. Burgess et al. 1972). Such patterns of damage illustrate how fragmentation was part of a trajectory that led to both single and hoarded deposits, as well as revealing the widespread practice that applied according to broader ontologies.

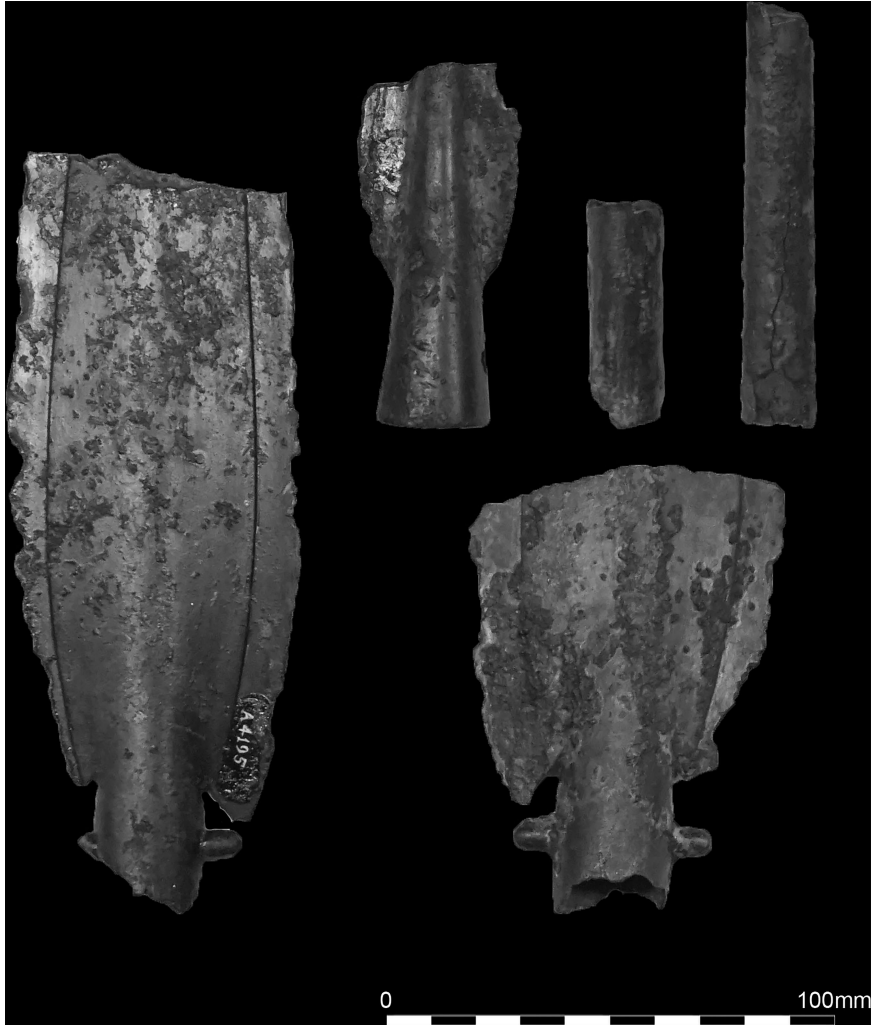

FIGURE 15.3 The Bloody Pool Hoard, Devon (photo: author, courtesy of Royal Albert Memorial Museum and Art Gallery, Exeter).

Furthermore, many of the objects in these weapon hoards show signs of combat damage, leading Mörtz (2018) to suggest that they were included and destroyed for their involvement in conflicts, perhaps the captured wares of a defeated enemy. Due to their violent histories, these weapons required a violent end. This is an appealing argument for the larger hoards, but I believe a greater range of interpretations should be considered for the single finds and smaller hoards showing signs of destruction. This was not just about selecting objects but also selecting treatments and places. By understanding

the destruction events as something separate from the act of deposition, we are observing actions with multiple meanings that are relevant at different times. If the destruction served one purpose, the deposition may serve another.

The collection from Bloody Pool, for instance, comprised large, barbed spearheads, which are typically considered ceremonial objects (Burgess et al. 1972:227–228). Their destruction may be related to managing powerful objects, removing them as symbols of authority, and requiring a person with material knowledge to undertake the act (Knight 2019). Pieces of the spearheads were then placed in a marshy pool, which may relate to an offering to the pool itself (Fox 1973:120).

What is particularly striking about these weapon deposits is their widespread nature. Unlike the EBA axeheads or the MBA ornaments presented so far, which were comparatively regionalised, ideas surrounding how to treat weapons and where to deposit them were structurally embedded within belief systems over the course of 200 years. The Bloody Pool hoard is the only example of a deliberately destroyed weapon hoard known from south-west Britain, and the Peelhill and Duddingston Loch examples are the only two from Scotland, yet they conform to broader practices seen elsewhere and seem to represent part of a scaled activity, that also involved single finds. People buried these objects in relation to wider belief systems and deposited one or more swords and spears, perhaps depending on the nature and importance of the event.

### **Fragmentation as a globalised practice: Late Bronze Age ‘scrap’ hoards**

Finally, we can turn to the end of the BA (c. 950–800 BCE), when thousands of fragmentary metal objects were deposited across Europe in hoards. These hoards are generally the focus of studies of fragmented metalwork. Were they abandoned dumps of metal? Or perhaps stashes of metalworking material? Our preoccupation with such questions has meant we have missed elements of the selective practices involved that are useful for illustrating similarities and differences within and across assemblages and areas and telling us something about how people were connected through practices. Vast numbers of objects were broken by heating and striking, and this would have been relatively straightforward. This then presents us with interpretive issues when some objects are heavily fragmented and others are left complete. Were certain objects selected for fragmentation?

One glimpse that this may have been the case comes from assessing the origins of distinct types of objects and different practices. A large hoard from Stogursey (Somerset) comprised about 146 objects, of which around 100 were deliberately fragmented, including many local object forms (McNeil

1973; Knight 2022:108–115). However, supra-regional axeheads that must have been exchanged into the region, including examples from Wales, Yorkshire and eastern England, were left complete, suggesting a recognition and differential treatment of non-local material. The hoard also encapsulated practices more common in south Wales, and thus we can view the hoard as the work of travelling ideas and people across the Bristol Channel (Knight 2022:115).

The Boughton-Vénat tradition that crossed the Channel between England and France similarly illustrates societal connections through shared practices (Briard 1965; Brandherm & Moskal-del Hoyo 2014). In both south-eastern England and Atlantic France, people gathered, fragmented and deposited large quantities of metalwork. This was a culturally shared practice. Similar material appears in both regions, though unlike at Stogursey, there is currently little to suggest that the origins of the objects had a bearing on their treatment before burial. Hoards of a similar fragmentary character are now recognised in western Cornwall and south-west Wales, suggesting people travelled, exchanging objects and sharing practices of accumulation and fragmentation up the Atlantic *façade* (Knight 2022:103–108).

These connections through practices become more striking when we consider the areas where fragmentation *did not* take place or was less common. For instance, we can contrast the situation in Atlantic France and south-east England with Ireland (Becker 2013), the southern Netherlands (Fontijn 2002) and northern Britain, where LBA hoards of fragmented objects were uncommon (O'Connor & Cowie 2022). We tend to think of fragmentation and deposition at this time as a globalised practice, which it was, but the choice to deposit fragments remained regionally varied. The Balmashanner hoard (Angus) included complete bronze armlets and rings, fragments of a cast bronze bowl, gold penannular rings, amber and cannel coal or shale beads, an iron ring and a deliberately broken socketed axehead fragment buried in a ceramic vessel (Anderson 1892). The Balmashanner assemblage still speaks of a diverse range of connections, including with Ireland and northern Europe, though fragmentation was only a small component. These hoards were deposited around the same time as the so-called 'scrap' hoards in the south, suggesting that there were different ideas behind how a deposit should be constructed that extended beyond economic and functional reasons; these were clearly not abandoned 'dumps' of material but may have been buried as a reflection of the connections between people in different areas or as offerings. However, even in these hoards, fragmentation still had a part to play, with occasional inclusions suggesting that there was also a choice to leave things unbroken. By seeing fragmentation as a globalised yet selective practice at this time, it forces us to recognise how people made deposits suitable according to the structures of local areas and the connections they were a part of.

## Conclusions

In this paper, I presented ideas relating to the ‘right way’ to treat objects, specifically where that right way constitutes deliberate destruction. I have termed this selective fragmentation. This is one facet of the wider scheme of the selective deposition of metalwork, but a focus on practices of destruction reveals how communities used fragmentation in diverse ways for different meanings and how it transformed over space and time. The case studies of deliberately damaged single and hoarded metalwork finds from Britain illustrate how, at times, fragmentation represented localised practices linked to communal ideologies, while at others it was part of more widespread patterns that demonstrate the connectivity of the BA world through shared ideologies. The selection and treatment of objects for deposits were often linked to the histories of the objects and their known associations, be they with people, places or even manufacturing origins. Where we observe diverse approaches to objects, as in the case of MBA ornaments, we can recognise that this was a reflection of and reaction to specific social situations. Approaching fragmentation specifically also enables us to conceptualise an event distinct from the act of deposition and consider the ways in which this brought certain people together and established an occasion ahead of burying the objects. A study of selective fragmentation thus becomes an integral part of the wider discussion of selective deposition, allowing us to recognise how destructive actions transformed objects and contributed to the formation of appropriate deposits. Fragmentation became a manifestation and expression of localised and wider ideas, creating deposits of meaning.

## Acknowledgements

I would like to thank the editors for inviting me to the conference in Stockholm, and subsequently, to contribute to this volume! Thanks also to the reviewers, other participants, and editors for their combined useful comments on earlier versions of this paper. All remaining imperfections are my own.

## References

- Anderson, J. 1892. Notice of the discovery of a hoard of the Bronze Age, consisting chiefly of personal ornaments of bronze, amber and gold, at Balmashanner, near Forfar. *Proceedings of the Society of Antiquaries of Scotland* 26: 182–188.
- Becker, K. 2013. Transforming identities - new approaches to Bronze Age deposition in Ireland. *Proceedings of the Prehistoric Society* 79: 225–263. <https://doi.org/10.1017/ppr.2013.8>
- Booth, T.J. & Brück, J. 2020. Death is not the end: radiocarbon and histo-taphonomic evidence for the curation and excarnation of human remains in Bronze Age Britain. *Antiquity* 94(377): 1186–1203. <https://doi.org/10.15184/aqy.2020.152>.

- Bradley, R. 1998 [1990]. *The passage of arms: an archaeological analysis of prehistoric hoard and votive deposits (2nd ed.)*. Oxford: Oxbow Books.
- Brandherm, D. & Moskal-del Hoyo, M. 2014. Both sides now: the carp's tongue complex revisited. *The Antiquaries Journal* 94: 1–47. <https://doi.org/10.1017/S0003581514000213>
- Briard, J. 1965. *Les dépôts bretons et l'âge du Bronze Atlantique*. Rennes: Travaux du Laboratoire d'anthropologie préhistorique.
- Bridgford, S.D. & Northover, J.P. 2020. *Three Bronze Age weapon assemblages from Norfolk*. Dereham: Historic Environment Service.
- Brück, J. 2004. Material metaphors. the relational construction of identity in Early Bronze Age burials in Ireland and Britain. *Journal of Social Archaeology* 4(3): 307–333. <https://doi.org/10.1177/1469605304046417>
- Burgess, C.B. et al. 1972. The Broadward Complex and barbed spearheads. In: F.M. Lynch & C.B. Burgess (eds) *Prehistoric man in Wales and the West: essays in honour of Lily F. Chitty*. Bath: Adams & Dart, 211–283.
- Byard, A. 2015. *BERK-456EE1: A BRONZE AGE HOARD* [online]. <https://finds.org.uk/database/artefacts/record/id/753607> [Accessed 11 August 2022]
- . 2016. The portable antiquities scheme in Oxfordshire, 2015. *Oxoniensia* 81: 239–246.
- Callander, J.G. 1922. Three Bronze Age Hoards recently added to the national collection, with notes on the Hoard from Duddingston Loch. *Proceedings of the Society of Antiquaries of Scotland* 56: 351–365.
- Chapman, J. 2000. *Fragmentation in archaeology: people, places and broken objects in the prehistory of South Eastern Europe*. London: Routledge. <https://doi.org/10.4324/9780203759431>
- Coles, J.M. 1969. Scottish Early Bronze Age metalwork. *Proceedings of the Society of Antiquaries of Scotland* 101: 1–110.
- Coombs, D. 1975. Bronze Age weapon hoards in Britain. *Archaeologia Atlantica* 1(1): 49–81.
- Cowie, T. 2004. Special places for special axes? Early Bronze Age metalwork from Scotland. In: I.A.G. Shepherd & G. Barclay (eds) *Scotland in ancient Europe: The Neolithic and Early Bronze Age of Scotland in their European context*. Edinburgh: Society of Antiquaries of Scotland, 247–261.
- Crellin, R.J. 2020. *Change and archaeology*. London: Routledge.
- Eogan, G. 1994. *The accomplished art*. Oxford: Oxbow.
- Evans, J. 1884. On a hoard of bronze objects found in Wilburton Fen, near Ely. *Archaeologia* 48: 106–114.
- Fontijn, D.R. 2002. Sacrificial landscapes: cultural biographies of persons, objects and 'natural' places in the Bronze Age of the southern Netherlands, c. 2300–600 BC. *Analecta Praehistorica Leidensia* 33/34: 1–392.
- . 2019. *Economies of destruction: how the systematic destruction of valuables created value in Bronze Age Europe, c. 2300–500 BC*. Abingdon, Oxon: Routledge. <https://doi.org/10.4324/9781315109879>
- Fox, A. 1973. *South-West England 3500BC-AD600 (2nd ed.)*. Newton Abbot: David & Charles.
- Gwilt, A. et al. 2007. Burton, Wrexham: Middle Bronze Age hoard of gold adornments and bronze tools with a pot (04.2). In: *Treasure Annual Report 2004*. Department of Culture, Media and Sport, 198–199.
- Johnston, R. 2021. *Bronze Age worlds: a social prehistory of Britain and Ireland*. London: Routledge.

- Knight, M.G. 2019. Going to pieces: investigating the deliberate destruction of Late Bronze Age swords and spearheads. *Proceedings of the Prehistoric Society* 85: 251–272. <https://doi.org/10.1017/ppr.2019.3>.
- . 2020. There's method in the fragments: a damage ranking system for Bronze Age metalwork. *European Journal of Archaeology* 24(1): 48–67. <https://doi.org/10.1017/ea.2020.21>.
- . 2022. *Fragments of the Bronze Age. The destruction and deposition of metalwork in South-West Britain and its wider context*. Oxford: Oxbow Books
- Maraszek, R. 2006. *Spätbronzezeitliche Hortfundlandschaften in atlantischer und nordischer Metalltradition*. Halle: Landesamt für Denkmalpflege und Archäologie Sachsen-Anhalt, Landesmuseum für Vorgeschichte.
- McNeil, R. 1973. A report on the Bronze Age hoard from Wick Park, Stogursey, Somerset. *Proceedings of the Somerset Archaeological and Natural History Society* 117: 47–64.
- Meeks, N.D. & Varndell, G. 1994: Three Bronze Age torc fragments from Woodham Walter, Essex. *Essex Archaeology and History* 25: 1–2.
- Mörtz, T. 2018. Violence and ritual in Late Bronze Age Britain: weapon depositions and their interpretation. In: C. Horn & K. Kristiansen (eds) *Warfare in Bronze Age Society*. Cambridge: Cambridge University Press, 168–188.
- Mörtz, T. et al. 2021. Peelhill Farm: a possible Late Bronze Age weapon sacrifice in Lanarkshire. *Proceedings of the Society of Antiquaries of Scotland* 150: 355–384. <https://doi.org/10.9750/PSAS.150.1320>.
- Murgia, A. et al. 2014. What have metal detectorists done for us? A case study of Bronze Age gold in England and Wales. *Archäologisches Korrespondenzblatt* 44(3): 353–367.
- Nebelsick, L. 2000. Rent asunder: ritual violence in Late Bronze Age hoards. In: C.F.E. Pare (ed.) *Metals make the world go round: the supply and circulation of metals in Bronze Age Europe*. Oxford: Oxbow Books, 160–175.
- Needham, S. 2001. When expediency broaches ritual intention: the flow of metal between systemic and buried domains. *The Journal of the Royal Anthropological Institute* 7(2): 275–298. <https://doi.org/10.1111/1467-9655.00063>.
- . 2007. Cirencester area, Gloucestershire: Bronze Age gold and base-metal scatter (2004 T416). In: *Treasure Annual Report 2004*. Department of Culture, Media and Sport, 26–33.
- Needham, S.P. 1983. *The Early Bronze Age axeheads of central and southern England*. Unpublished Ph.D thesis. Cardiff University.
- . 1988. Selective deposition in the British Early Bronze Age. *World Archaeology* 20(2): 229–248.
- . 2004. Migdale-Marnoch: sunburst of Scottish metallurgy. In: I.A.G. Shepherd & G.J. Barclay (eds) *Scotland in ancient Europe: The Neolithic and Early Bronze Age of Scotland in their European context*. Edinburgh: Society of Antiquaries of Scotland, 217–245.
- O'Connor, B. & Cowie, T. 2022. From *Ultima Thule*: fragmentation in the Bronze Age metalwork of Scotland? In: J.-M. Doyen (ed.) *De l'Escaut au Nil. Bric-à-brac en hommage à Eugène Warmenbol*. Brussels, Editions de Cedarc, 321–326.
- Piggott, S. & Stewart, M. (eds) 1958. *Inventaria Archaeologica 5th Set: GB.25-34*. London: Garraway Ltd.
- Ramsey G. 2013. A twisted torc. *Archaeology Ireland* 27(3): 26–27.

- Roberts, B.W. 2007. Adorning the living but not the dead: understanding ornaments in Britain c. 1400–1100 cal BC. *Proceedings of the Prehistoric Society* 73: 135–167. <https://doi.org/10.1017/S0079497X00027328>.
- Savory, H.N. 1958. The Late Bronze Age in Wales. Some new discoveries and new interpretations. *Archaeologia Cambrensis* 107: 3–63.
- Smith, M.A. (ed.) 1959. *Inventaria Archaeologica 7th Set: GB.42-47*. London: Garraway Ltd.
- Stevenson, R.B.K. 1948. Notes on some prehistoric objects. *Proceedings of the Society of Antiquaries of Scotland* 82: 292–295.
- Strathern, M. 1988. *The gender of the gift*. Berkeley: University of California Press.
- Wilkin, N. 2017. Combination, composition and context: readdressing British Middle Bronze Age ornament hoards (c. 1400–1100 cal. BC). In: T.F. Martin & R. Weetch (eds) *Dress and society: contributions from archaeology*. Oxford: Oxbow Books, 14–47.
- Woodward, A. 2002. Beads and beakers: heirlooms and relics in the British Early Bronze Age. *Antiquity* 76(294): 1040–1047. <https://doi.org/10.1017/S0003598X00091845>.
- York, J. 2002. The life cycle of Bronze Age metalwork from the Thames. *Oxford Journal of Archaeology* 21(1): 77–92. <https://doi.org/10.1111/1468-0092.00150>.

# 16

## PIECES OF THE PAST, FRAGMENTS FOR THE FUTURE – BROKEN METALWORK IN NORDIC LATE BRONZE AGE HOARDS AS MEMORABILIA?

*Anna Sörman*

### Introduction

Fragmentation of valuable metalwork was a widespread practice in Late Bronze Age Europe (e.g. Rezi 2011; Hansen 2016; Milcent 2017; Knight 2022). Broken bronze objects are found in various contexts, but primarily in hoards – assemblages of mixed metalwork intentionally placed in the ground. Depositions containing a large proportion of fragments have traditionally been termed ‘scrap hoards’ or ‘smith’s hoards’, which hints at the most common archaeological explanation of this phenomenon: as scrap for recycling or trade (e.g. Oldeberg 1928; Levy 1982; Weiler 1996). It has largely been assumed to be the smith’s hidden stock of raw material, and that the fragments of commodified metal would thus eventually be transformed into proper objects again. The idea of ‘scrap’ is clearly influenced by modern, western concepts where the incomplete and damaged were dismissed as refuse – a view that cannot be assumed to be valid for prehistory (Chapman 2000; Chapman & Gaydarska 2007; Brück 2016).

Over the last decades, new readings of these hoards have demonstrated patterns that cannot easily be explained as simple scrapping. Instead, case studies from across Europe indicate that fragmentation and hoarding of ‘scrap’ followed different norms and patterns across time and space (e.g. Gabillot 2004; Gabillot & Lagarde 2008; Rezi 2011; Dietrich 2014; Brück 2016; Hansen 2016; Knight 2022, this volume). Various and simultaneous motives for breaking bronze objects have been proposed and attested: to facilitate commodification and exchange (e.g. Milcent 2017; Brandherm 2018; Ialongo & Lago 2021), but also to enable the use of fragments in depositions and transactions for more symbolic ends. Such interpretations include observations of *pars pro toto* sacrifices, curated fragments as relics or

heirlooms and their partition and structured deposition as a means to create real and symbolic links – enchainments (Chapman 2000; Brück & Fontijn 2013:212; Dietrich 2014; Brück 2016, this volume; Hansen 2016). These insights begin to reveal the complexity behind this widespread and characteristic LBA practice.

This paper aims to contribute to the understanding of this phenomenon in a Nordic Bronze Age (BA) context by studying a selection of ‘scrap’ hoards from modern-day Sweden. What do the buried fragments look like, what object types are represented, which fragments were included and which are ‘missing’? While only scratching the surface, this study provides a basic characterization, indicating questions for future studies on a phenomenon that has remained largely unstudied in Scandinavia since the beginning of the 20th century. These observations will be used to discuss the question of the potential purposes of the broken objects in the Nordic LBA ‘scrap hoards’. What were the economic, social and possibly symbolic values of different metalwork parts? In this chapter, I elaborate on the idea that the fragments in ‘scrap’ hoards were carefully chosen and curated, and one of the keys to the fragmented hoard assemblages in dry (retrievable) places is that the individual pieces would remain recognizable over time. This has implications

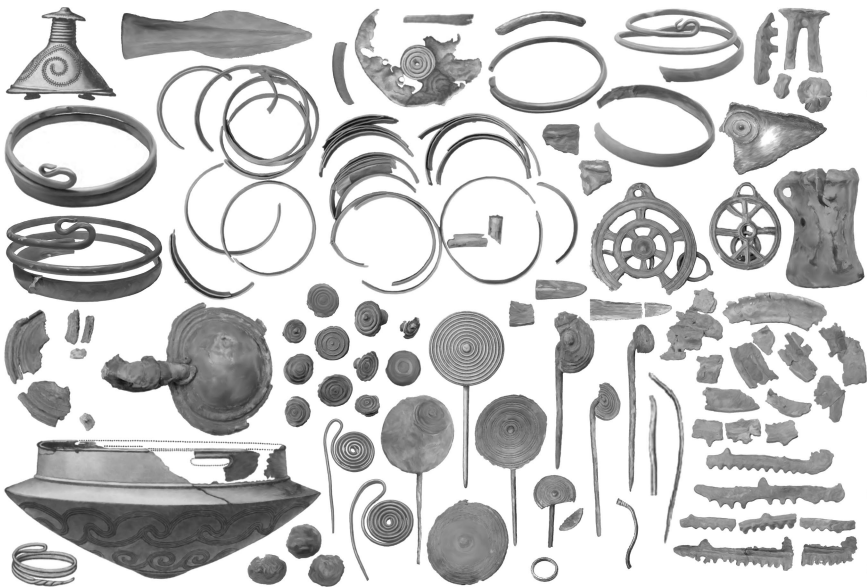

**FIGURE 16.1** Parts of the Late Bronze Age hoard from Härnevi in central Sweden, containing a large portion of incomplete objects and often interpreted as a ‘scrap hoard’. Note that not all breaks are ancient (illustration by Magdalena Forsgren, reprinted with kind permission).

for interpreting the values, use and reuse of fragments in this region, as well as for understanding the ‘scrap’ hoard phenomenon and the people behind these depositions.

### Bronze and hoarding in Late Bronze Age southern Scandinavia

Bronze in LBA Scandinavia was a highly valued and exotic material acquired from areas abroad via gifts and exchange (e.g. Levy 1999; Ling et al. 2014). From a rather limited repertoire of axes, weapons and ornaments in the Early Bronze Age (c. 1700–1100 BCE), the production of bronze metalwork intensified and diversified in the LBA (c. 1100–500 BCE). The range of objects conceived in the sun-glowing alloy now included weapons, personal ornaments, toilet equipment, dress fittings, large costume attributes, various tools and a large range of rare cult objects such as figurines, ceremonial helmets, horse and wagon decorations and even extravagant musical instruments in the form of bronze lures (e.g. Baudou 1960; Levy 1999). Many tools were made of flint, stone and bone, while bronze tools only represented a fraction of the toolkit. I agree with the notion that the Nordic BA metalwork was dominated by ritual, prestigious and socially valuable objects, while its involvement in the productive economy through tools was quite limited compared to other areas in BA Europe (e.g. Thrane 1975:247; Bradley 1990:143).

Landscape depositions of bronze metalwork occurred throughout the Nordic BA. In southern Scandinavia, like elsewhere, depositions have often been categorised as either sacrificial or profane based on their find contexts and retrievability (e.g. Levy 1982; Bodilsen 1986; Rundkvist 2015). This classification partly rests on the premise that wet contexts are less likely to have been revisited and therefore were meant as final resting places, while dry contexts, at least theoretically, facilitate revisits and retrieval (see Brück 2016). BA depositions in southern Scandinavia are predominantly found in or in direct association with water, such as lakes, bogs, rivers and sea inlets (Levy 1982; Fredengren 2011; Rundkvist 2015).

Dry-land locations (such as hillsides, under large boulders or in rock crevices) also appear and are more common for hoards with a large degree of fragmentation. In addition, hoards with a high fragmentation rate more often include material associated with bronze casting, another argument traditionally raised in favour of a ‘profane’ interpretation. A previous study estimated 13% of the circa 125 LBA hoards in Sweden as being ‘scrap hoards’, then defined by the inclusion of ‘raw stuff or ingots’, such as casting refuse, unfinished metal rods and/or fragmented tools (Weiler 1996:21). To summarise, fragmented bronze objects are *mostly but not only* found in dry-land hoards, and casting debris is *mostly but not only* found with fragmented objects. Hoards with broken versus complete objects, as well as in wet versus dry

depositional contexts, are variations on the same theme rather than opposite categories.

### Approaching fragmented bronze in Late Bronze Age Scandinavia

Fragmented metalwork in the Nordic BA largely remains unexplored. Hoard studies have often focused on depositions in wet contexts, where fragmentation is less frequent. The typo-chronological studies dominating previous research have also meant a primary interest in the most complete and well-preserved objects. Fragmented metalwork and ‘scrap hoards’ have been the topic of a few minor studies focusing on technical (Oldeberg 1927, 1928, 1929, 1934) and economic (Weiler 1996) aspects. This situation reflects the much-critiqued division of ‘scrap hoards’ as economical and pragmatic in contrast to the ritualistically or religiously explained ‘sacrificial hoards’, a division seen throughout the academic history of this subject (for critique, see e.g. Brück & Fontijn 2013:210–212; Brück 2016; Fontijn 2019). This paper works from the premise that fragmentation, curation and reuse of ‘scraps’ must be studied as culturally as well as economically meaningful.

Fragmented BA metalwork is not only known from hoards, but finds from different contexts have not yet been synthesised or compared. LBA burials sometimes contain metalwork, often small and incomplete objects (e.g. Bodilsen 1986:6; Röst 2016; Hornstrup 2018). Fragmented bronzes are also known from settlement contexts but are often regarded as waste or accidentally lost objects (Eriksson & Grandin 2008). So far, there are a few known cases where bronze fragments were subjected to intentional secondary use. One particularly interesting example is from a Swedish burial ground where two fragments, seemingly from the same neck ring, were found in two different graves (Röst 2016:220, 238). Fragments were sometimes also reused by being converted into new objects or integrated as part of repairs or modifications (e.g. Hornstrup 2018; Ojala & Sörman this volume). Thus fragments evidently had various uses ‘after the break’: circulated, curated, converted, possibly re-melted and deposited. The ‘scrap hoard’ phenomenon appears to be only the tip of the fragmentation iceberg when considering how much broken metalwork was once in circulation.

Fragmenting something does not strip it of its value but transforms it (e.g. Chapman 2000; Chapman & Gaydarska 2007; Dietrich 2014). Multiple new parts with changed properties are created, which are available for continued use. Scrap hoards from various parts of BA Europe have been characterised as ‘codified’; objects and fragments give an impression of selection and repeated patterns, hinting at local and regional norms (e.g. Gabillot 2004; Bradley 2005:152–153; Rezi 2011; Hansen 2016; Milcent 2017; Bordas & Boulud-Gazo 2018:25–31; Brandherm 2018; Dietrich & Mörtz 2019; Knight 2022). For example, Richard Bradley has noted that sword hilts are more

represented than blades in many European LBA ‘scrap hoards’; considering the proportion of the hilt compared with the whole object, this relationship should be inverted (Bradley 2005:152–153, as referenced in Brück & Fontijn 2013:200). Trying to characterise these assemblages and identify patterns, the sample of Swedish ‘scrap hoards’ will here be evaluated based on the following questions:

- What object types in these hoards are fragmented more often versus more rarely?
- To what extent can the original object type be identified from the fragments?

### Studying a selection of Swedish ‘scrap hoards’

Five metalwork hoards from present-day central and southern Sweden have been included in this study: hoards from Bräckan, Härnevi, Hjärpetan, Nya Åsle and Ystad (Table 16.1). All but one are from dry-land contexts, found under large stones (2. Härnevi, 3. Hjärpetan and 5. Ystad). One of these (3. Hjärpetan) was found in a small stone-cist construction under a large stone on the terrace of a rocky hillside. One was found in a ceramic vessel on a sandy slope, but the exact circumstances are unknown (1. Bräckan). Finally, one differed from the rest by being found under a large boulder in a bog, thus in what can be considered a wet context (4. Nya Åsle).

These hoards were chosen for two main reasons: Firstly, because of their high fragmentation rates and because they have all previously been discussed as ‘scrap hoards’ (e.g. Oldeberg 1927, 1928, 1929, 1934; Weiler 1996). Secondly, the documentation available is of relatively high quality and detail. The finds are described either in museum catalogue entries or in publications dedicated to individual hoards. This is crucial, as this study relies on previous observations rather than primary empirical work, with the exception of the Härnevi hoard (Figure 16.1), which was studied and recorded first-hand at the Swedish History Museum (SHM), Stockholm.

Information about the appearance of objects, fragments and breakage of objects in all hoards except Härnevi is based on notes, photographs and drawings. Four of the hoards have been published by Andreas Oldeberg (1927, 1928, 1929, 1934), an antiquarian at the SHM in the first half of the 20th century, who was specially interested in ancient metalworking techniques and the BA. His detailed accounts include systematic recordings of fresh versus old breakage based on patina and information from the people who discovered the hoards. Such information is invaluable and facilitates the discussion on LBA fragmentation. Nevertheless, it should be emphasised that renewed empirical studies could lead to revisions of the results. A detailed database cataloguing the finds in each hoard can be found in a digital repository (Sörman 2023).

**TABLE 16.1** The Late Bronze Age hoards included in this study, with fragmentation rates (\*number of fragments in relation to the total number of items except casting debris, omitting breaks considered recent) ranging from about 50% to almost 90%

No	Find spot [museum identifier]	Typological dating	Total number of object pieces (casting debris excluded)	Fragmentation rate (based on quantity*)	Casting debris
1	Bräckan [SHM 1995]	Period IV (c. 1100– 900 BCE)	80 (61)	(54) 89%	Yes
2	Härnevi [SHM 11635 & 1612]	Period IV–VI (c. 1100–500 BCE)	143 (139)	(79) 57%	Yes
3	Hjärpetan [SHM 17093 & 17143]	Period V (c. 900–700 BCE)	37 (36)	(23) 64%	Yes (+ lead ingot)
4	Nya Åsle [SHM 4127]	Period V (c. 900–700 BCE)	145 (136)	(71) 52 %	Yes
5	Ystad [YM 1388–1415]	Period V (c. 900–700 BCE)	29 (25)	(19) 76%	Yes

All five hoards were recovered before 1930, none of them by archaeologists. Hence, there is a range of source-critical problems regarding the objects, retrieval and recording. In particular, smaller fragments were presumably overlooked or remained undiscovered to a certain extent, considering that the discoveries predate the use of metal detectors and occurred in times when complete objects were generally seen as more valuable and therefore perhaps prioritised. These conditions mean that the hoards are probably incomplete, which impacts the accuracy of the calculated rates for fragmentation as well as the number of identifiable fragments. Regardless of this potential error margin, the fragmentation rates for these assemblages are staggeringly high (Table 16.1). Considering that smaller fragments were potentially overlooked, the fragmentation rates can be seen as a *minimum*. Although the number of unidentifiable pieces might initially have been slightly lower if smaller fragments were left out at discovery, the recognisability of the remaining fragments, including the smallest ones recovered, indicates that unrecognisable fragments in these hoards were rare.

### Chronology, fragmentation rate and general composition

The hoards all contain object types typologically dated to the LBA. It is interesting to note that the age span represented in these assemblages is approximately limited to single typologically defined BA periods, each of which is

around 200 years. In the Period V hoards of Hjärpetan and Nya Åsle, the presence of some older objects from Period IV or ‘early’ Period V (Oldeberg 1928:324, 343–344; Oldeberg 1934:17) indicate that the assemblages have a certain time depth and was compiled throughout the period. In the Härnevi hoard, there are objects from LBA Periods V and VI and possibly even from late Period IV (Jensen 1997:180). This also hints at a wider chronological span and indicates that this practice sometimes continued throughout several stylistic horizons. Such a circumstance supports the impression that these assemblages were accumulated over time, within one or two Nordic BA periods (or even three, in the case of Härnevi). Consequently, this raises the question of whether the objects would have been accumulated and curated somewhere else before being deposited in the ground or whether the depositional place was also the storage location to which items were gradually added.

A majority (c. 50%–89%) of the items in these hoards are fragments or incomplete pieces when calculated according to quantity rather than weight, casting debris excluded (Table 16.1; Sörman 2023). Four out of five hoards also contain some form of metalworking debris, such as casting sprues or lumps of bronze. Of a total of c. 440 items from the five hoards, 34 pieces are recorded as having signs of additional, voluntary damage, such as cases of bending, crushing/flattening or stuffed sockets (Sörman 2023). Regarding represented object types, the assemblages are heterogenous, containing a broad variety of objects. All hoards contain objects or object fragments from all the traditional categories of weapons, tools and dress/body ornaments. Most of the hoards include at least one object of non-local type (Oldeberg 1927, 1928, 1934), but a clear majority of the objects appear to have been produced in the Nordic area.

### Objects types

There are indications of selection and disproportion among the objects chosen for fragmentation. The hoards do not contain all known object types in circulation, nor does the content reflect the approximate ratios between various groups of objects (for example, socketed axes are believed to have been much more common than swords). Some types often end up in these assemblages, while others are rare or almost missing completely.

In the Swedish hoards studied here, commonly fragmented objects are: swords, arm rings, sickles, spearheads and axes. Although present in four out of five hoards, no swords are found intact. Object types that were fragmented but rarer are neck rings, fibulas, dress pins, double buttons, knives, punches and chisels. All spectacle fibulas and neck rings are incomplete. The same is true for some of the large, rare items such as lures and bronze vessels. The most unique items correspond to what probably also constituted rarer objects at the time, such as decorative wheel pendants (Härnevi), fish hooks

(Bräckan), bronze vessels (Nya Åsle) and lures (Hjärpetan, Nya Åsle). Less surprisingly, some highly unusual object types, such as bronze combs and belt hooks, are missing from these assemblages. Objects that appear both complete and incomplete in these hoards include spearheads, axes, dress pins, double buttons, arm rings, sickles and knives. With some exceptions, we lack several fragments or the rest of the object. This means that most pieces of the objects represented by the fragments are missing.

There are also object types that are conspicuously absent in these assemblages. The least frequent items in the scrap hoards are the ones from the toilet set. The 'toilet set' is here defined as including a razor and tweezers, and sometimes also a knife and double button, which formed a set of small, personal items. Only one razor is present in this dataset: an intact, decorated specimen from the Hjärpetan hoard (Oldeberg 1928:331). Tweezers have not been found in any of the five hoards. Pieces of such small, flat objects might be harder to recognise in the form of small fragments, but their trapezoid shape, specific dimensions, and occasional ornamentation would have enabled identification, and they are recognised as fragments when found in burials. Razors and tweezers are also largely missing from the depositions in wet contexts (Baudou 1960; Levy 1982; Rundkvist 2015). However, they appear in some LBA burials, where they are sometimes fragmentary (e.g. Baudou 1960; Hornstrup 2018). Razors and tweezers were thus mostly considered inappropriate for landscape deposition.

Finally, a note about the difference in neck rings: while simple and twisted neck rings are present in all five hoards, more elaborate neck ring pieces are absent. LBA elaborate neck ring designs, such as various heftier neck rings with ornamentation, spiral-formed end-plates, etc., are generally missing. Two fragments from the Ystad hoard and two fragments from the Nya Åsle hoard might originate from such rings, but the pieces represented are from the simple, twisted part rather than the extravagant end-plates (Oldeberg 1927:109, 1934:25).

Hence, we sense a mutually exclusive pattern of deposition where certain small personal items are never (tweezers) or rarely (razors) included in these assemblages, but instead appear in other contexts, notably burials. The same is true for the elaborate neck rings, which, in contrast to the often fragmented simple and twisted neck rings, only appear in other hoard configurations. All other frequent forms of LBA metalwork are represented. This means that the person(s) who collected, curated and deposited these assemblages followed specific norms about what to include rather than adding fragments from all types in circulation.

### **Recognisability**

An absolute majority of the pieces found in scrap hoards can be determined by which object type they once belonged to. Even the smallest recovered

fragments are identifiable to a high degree because of particular traits. Very small fragments are often possible to identify due to their curvature (lure fragments), shape and thickness (bronze vessels), or preserved details such as handles, decorative elements, rims, cutting edges or other particularities (Figure 16.2). The unidentified or uncertain fragments in relation to the total number of fragments for each hoard are 6% (3 fragments) for Bräckan, 1% (1 fragment) for Härnevi, 0% (0 fragments) for Hjärpetan, 8% (6 fragments) for Nya Åsle and 0% (0 fragments) for Ystad (Table 16.1).

In most cases, the unidentifiable pieces have a broken edge on several or all sides. Characteristics occurring on several of the unidentifiable fragments, such as a rim, an angle or a decoration (e.g. Oldeberg 1928:333; SHM 1995 no 791:32; Figure 16.2), would probably have made them distinguishable by the people who had seen the original object. We should here consider that rare objects, such as pieces of large hammered vessels, were potentially more easily recognisable in the past. Since no such items were produced locally and there were fewer of these objects in circulation, fragments from these objects would have been more unique in the local community. Interestingly, fragments from large bronze vessels – objects with large surface areas that would break into many fragments – are still only represented by very few pieces (e.g. SHM 7994 and Nya Åsle), another fact indicating a selection process behind the composition of these hoards.

To sum up, a vast majority of the fragments are identifiable as to the original object type. Many of the pieces that we cannot identify today were probably still recognisable to people who were familiar with them when they were in use or because they were pieces of rarity (such as vessels of hammered bronze or larger, decorated objects). Even considering the source-critical



1 cm

**FIGURE 16.2** Fragment of an unidentified object from the Härnevi hoard (photo by the author).

factor of small and less recognisable fragments potentially having been left out or overlooked by 19th and 20th-century finders or museum workers, the recognisable fragments form such a dominant proportion that keeping identifiable pieces must have been a significant factor in this hoarding practice.

### Fragments as memorabilia?

In all Swedish hoards studied here, there is a high recognisability of the fragments included in the assemblages. Even if we consider the possibility that dozens of small, unrecognisable fragments were overlooked by the finders, the large part of these hoards was made up of bits and pieces that are large enough to be identified by us (archaeologists familiar with the BA metalwork repertoire) and then probably also by people in the BA. Recognisability relates to the fragments' visual form. Fragmenting in relation to certain shapes and attributes, as well as the fragment size, dictates if the pieces are recognisable or not. There are no marks or any other additions to the fragments that would have allowed the identification of each piece. Objects in hoards might have been divided into various organic containers, allowing for physically separating or grouping certain bits and pieces. Unfortunately, such information is not possible to assess for the findings studied here. We can probably assume that they, like us, primarily relied on the shape of fragments for general or precise identification.

If each object included in a hoard assemblage embodied the histories of its previous users and owners, hoards upheld a multitude of past narratives (Chapman 2000:117). The first question we must ask is: did the histories and relations of these fragments matter, or had broken pieces been commodified as raw material and thereby deprived of their previous functions, values and meanings? The inclusion of fragments with high recognisability was certainly not done with the intention of making life easier for future archaeologists. So why were not (to our knowledge) smaller and less obvious pieces included? Perhaps less emblematic pieces were used in other contexts where the preserved form was less important, such as for finite deposition or immediate re-melting into a new object? Contrastingly, in hoarded collections where people would successively add or withdraw fragments, their history would be of continual importance. Selecting pieces where their original function remained visible/tangible allowed for these curated items to continue to be associated with their original owner or use history. Supposing that incomplete objects, and even small pieces, were still recognised with reference to their original whole, a 'scrap hoard' would have involved as many associations with past 'wholes' as they contained fragments.

As initially highlighted in the works of John Chapman (2000), the fragment's recognisability *vis-à-vis* the original whole is a key to the potential link between fragmentation and memory, along with the capacity to transmit

references to the ‘original’. This allows for the link to memories to be upheld and thus relates to the archaeological key questions regarding the role of material culture in creating, maintaining and manipulating the collective and individual memories of people in the past (e.g. Bradley 2002; Jones 2007). What was thought of these objects from the recent past during the LBA? In his discussion of memorabilia and heirlooms, Chris Caple has made a useful distinction between ‘ancestral objects’, as items with known history and perhaps even a genealogy of ownership, versus ‘venerable artefacts’, detached from direct experience, and part of a more distant, mythical or socially defined and agreed past (Caple 2010:307). Many bronze objects in the scrap hoards, such as weapons and dress items, were personal attributes dating from within one or two chronological periods of the Nordic BA and would have been intimately linked to individuals or institutions. Consequently, we can assume that these assemblages represented ancestral memories of known histories and persons. They were also object types that continued to be produced, rather than old, abandoned object forms. They would probably have been assembled and curated by people from the same community, or at least from the same tradition. Various studies have shown that objects in LBA hoards show signs of wear and use (e.g. Kristiansen 2016 [1974]). These were objects that, before their deposition, had generally been used, worn and displayed in society.

Finally, the relatively limited size of these assemblages (ranging roughly between c. 30 and 150 pieces) means that the fragments were identifiable not only in terms of type but potentially also as to *which exact object* they once belonged to. This has two major consequences: not only could it facilitate the mnemonic link back to their previous owners, users, histories, and deeds, if locally made, this identification could also link back to the object’s production, meaning local metalworkers might have even been able to recall or at least understand the conditions for its composition and production. In this regard, these ‘scrap hoards’ are set apart both by size (and weight) and by fragment size compared to some of their LBA counterparts in Europe (e.g. Bordas 2019; Dietrich & Mörtz 2019:281; Knight 2022:156). In contrast to collections with tens or hundreds of kilograms and hundreds or thousands of objects, the Nordic LBA ‘scrap hoards’ were small caches of identifiable object parts that facilitated recognisability and commemoration. The fact that these had value as memorabilia has to be considered for at least parts of this material.

Scrap hoards and depositions with a high degree of fragmented objects in Scandinavia have previously been linked to crafting or trade (Oldeberg 1927; Weiler 1996), but they have also been suggested to represent a form of local or regional ‘settlement deposits’ [Swe. *bygddepåer*], functioning as a centralised storage of wealth for a larger kin group (Thedéen 2004:72–74). Considering their possible association with the specialised metalworkers, they have also been suggested to function as a socio-politically charged source

for valuable, reusable or recyclable metals and relics curated by the smith (Goldhahn 2007:219; see also Fregni 2014). I agree with this and have previously pointed to ethnographic examples of relic hoards curated by smiths (Sörman 2018:186–187). It is not likely that all hoards with fragments were ‘scrap hoards’, nor that all fragments in such hoards served the same purpose or were assembled and deposited for the same reason. However, it seems likely that the majority of the so-called ‘scrap hoards’ were accumulated over time and that they were, at least in part, linked to memory work.

### **Final reflections**

Metalwork assemblages with large proportions of fragmented objects deposited in the landscape – known as ‘scrap hoards’ – consist mainly of pieces with shapes or characteristics that make them recognisable. This raises questions regarding the strategies for making, using and conceptualising fragments: Were fragments created or selected with the intention of keeping the visual reference to the original object? Were different pieces of objects treated differently? Were some parts – such as edges, tips, handles and rims – more or less likely to be chosen for inclusion in ‘scrap hoards’ than others? Fragmenting Scandinavian LBA metalwork resulted in a variety of pieces with different qualities. We should therefore also be sensitive to how specific object categories with distinctive forms and decorations lend themselves to fragmentation (Chapman 2000:65). An issue to consider in further studies of fragmented metalwork is whether pieces of different shapes and visual properties, but also of different qualities such as portability, size, weight and shape, affected the ways different fragments were circulated, reused and deposited. Understanding this variation is a challenge, but it is also one of the great creative potentials of bronze objects as fragmented matter. While opening more questions than it answers, it is proposed that origins and commemoration were central to the value of these hoards.

### **Acknowledgements**

This research was partly carried out during my time as a postdoctoral fellow funded by the Wenner-Gren Foundations (WGF2021-0006). This work also benefited from support from Åke Wiberg’s Foundation (H20-0108).

### **Data availability statement**

The data that support the findings of this chapter are openly available in the research data repository of the Swedish National Data Service at <https://doi.org/10.58141/5x6w-mx80> (Sörman 2023).

## References

- Baudou, E. 1960. *Die regionale und chronologische Einteilung der jüngeren Bronzezeit im Nordischen Kreis*. Stockholm: Almqvist & Wiksell.
- Bodilsen, I. 1986. Religiøse nedlæggelser i dansk bronzealder. In: E. Mikkelsen (ed.) *Det 4. nordiske bronsalder-symposium på Isegran 1984*. Oslo: Oslo University, 5–16.
- Bordas, F. 2019. *Le dépôt de Keriéro à Bangor : et la fin de l'âge du Bronze dans le Morbihan : Document préparatoire*. Unpublished report.
- Bordas, F. & Boulud-Gazo, S. 2018. Les dépôts métalliques de la fin de l'âge du Bronze dans le Morbihan: remarques sur quelques dépôts de l'horizon de l'épée du type en langue de carpe. *Bulletin et mémoires du Morbihan de la société Poly-mathique CXLIV*: 13–45.
- Bradley, R. 1990. *The passage of arms: an archaeological analysis of prehistoric hoards and votive deposits*. Cambridge: Cambridge University Press.
- . 2002. *The past in Prehistoric societies*. London: Routledge.
- . 2005. *Ritual and domestic life in Prehistoric Europe*. London: Routledge.
- Brandherm, D. 2018. Fragmentation patterns revisited: ritual and recycling in Bronze Age depositional practice. In: D. Brandherm et al. (eds) *Gifts, goods and money: comparing currency and circulation systems in past societies*. Oxford: Archaeopress, 45–65.
- Brück, J. 2016. Hoards, fragmentation and exchange in the European Bronze Age. In: S. Hansen et al. (eds) *Raum, Gabe und Erinnerung: Weibgaben und Heiligtümer in prähistorischen und antiken Gesellschaften*. Berlin: Edition Topoi, 75–92.
- Brück, J. & Fontijn, D. 2013. The myth of the chief: prestige goods, power, and personhood in the European Bronze Age. In: H. Fokkens & A. Harding (eds) *The Oxford handbook of the European Bronze Age*. Oxford: Oxford University Press, 197–215.
- Caple, C. 2010. Ancestor artefacts - ancestor materials. *Oxford Journal of Archaeology* 29(3): 305–318. <https://doi.org/10.1111/j.1468-0092.2010.00350.x>
- Chapman, J. 2000. *Fragmentation in archaeology: people, places, and broken objects in the prehistory of south-eastern Europe*. London: Routledge. <https://doi.org/10.4324/9780203759431>
- Chapman, J. & Gaydarska, B. 2007. *Parts and wholes: fragmentation in prehistoric context*. Oxford: Oxbow Books.
- Dietrich, D. 2014. Learning from 'scrap' about Late Bronze Age hoarding practices. A biographical approach to individual acts of dedication in large metal hoards of the Carpathian Basin. *European Journal of Archaeology* 17(3): 468–486. <https://doi.org/10.1179/1461957114Y.0000000061>
- Dietrich, D. & Mörtz, T. 2019. Sockets full of scrap? Remarks on deliberate fragmentation in Late Bronze Age metal deposits in south-eastern and north-western Europe. In: D. Brandherm (ed.) *Aspects of the Bronze Age in the Atlantic archipelago and beyond: proceedings from the Belfast Bronze Age Forum 9–10 November 2013*. Hagen/Westf.: curach bhán publications, 281–297.
- Eriksson, T. & Grandin, L. 2008. Brons - den gyllene metallen. In: E. Hjärthner-Holdar et al. (eds) *Mellan himmel och jord - Ryssgården, en guldkimrande bronsåldersmiljö i centrala Uppland*. Uppsala: The Swedish National Heritage Board, 325–369.

- Fontijn, D. 2019. *Economies of destruction: how the systematic destruction of valuables created value in Bronze Age Europe, c. 2300–500 BC*. London: Routledge. <https://doi.org/10.4324/9781315109879>
- Fredengren, C. 2011. Where wandering water gushes: the depositional landscape of the Mälaren valley in the late Bronze Age and earliest Iron Age of Scandinavia. *Journal of Wetland Archaeology* 11(1): 109–135. <https://doi.org/10.1179/jwa.2011.10.1.109>
- Fregni, E.G. 2014. *The complete metalsmith: craft and technology in the British Bronze Age*. Unpublished PhD thesis, University of Sheffield.
- Gabillot, M. 2004. La fragmentation des objets : critère d'étude des dépôts de l'âge du Bronze. In: P. Bodu & C. Constantin (eds) *Actes du 25ème Congrès Préhistorique de France : approches fonctionnelles en Préhistoire, Nanterre, 24-26 novembre 2000 : 1-9*. Paris: Société préhistorique française, 193–201.
- Gabillot, M. & Lagarde, C. 2008. Voluntary destructions of objects in Middle and Late Bronze Age hoards in France. In: C. Hamon & B. Quilliec (eds) *Hoardings from the Neolithic to the Metal Ages: technical and codified practices*. Oxford: Archaeopress, 59–65.
- Goldhahn, J. 2007. Dödens hand: en essä om brons- och hållsmed. In: J. Goldhahn & T. Östigard (eds) *Rituelle specialister i brons- och jernalderen*. Gothenburg: Gothenburg University, 21–373.
- Hansen, S. 2016. A short history of fragments in hoards of the Bronze Age. In: H. Baitinger (ed.) *Materielle Kultur und Identität im Spannungsfeld zwischen Mediterraner Welt und Mitteleuropa*. Mainz: Verlag des Römisch-Germanischen Zentralmuseum, 185–208.
- Hornstrup, M. K. 2018. Fragmenter, omdannede genstande og social status i yngre bronzealder. In: S. Boddum & N. Terkildsen (eds) *Status og samfundsstruktur i yngre bronzealders kulturlandskab*. Viborg & Holstebro: Viborg Museum & Holstebro Museum, 101–113.
- Ialongo, N. & Lago, G. 2021. A small change revolution. Weight systems and the emergence of the first Pan-European money. *Journal of Archaeological Science* 129(105379): 1–14. <https://doi.org/10.1016/j.jas.2021.105379>
- Jensen, J. 1997. *Fra Bronze- til Jernalder – en kronologisk undersøgelse*. Copenhagen: Det Kongelige Nordiske Oldskrift-Selskab.
- Jones, A.M. 2007. *Memory and material culture*. Cambridge: Cambridge University Press. <https://doi.org/10.1017/CBO9780511619229>
- Knight, M. 2022. *Fragments of the Bronze Age: the destruction and deposition of metalwork in south-west Britain and its wider context*. Oxford: Oxbow Books.
- Kristiansen, K. 2016 [1974]. *En analyse af yngre bronzealders Depotfund (Periode IV-V) i Danmark: kildekritik, kronologi og tolkning*. Gothenburg/Academia.edu.
- Levy, J.E. 1982. *Social and religious organization in Bronze Age Denmark: an analysis of ritual hoard finds*. Oxford: BAR Publishing.
- . 1999. Metals, symbols, and society in Bronze Age Denmark. In: J. Rodd (ed.) *Material symbols: culture and economy in prehistory*. Carbondale: Southern Illinois University, 205–233.
- Ling, J. et al. 2014. Moving metals II: provenancing Scandinavian Bronze Age artefacts by lead isotope and elemental analyses. *Journal of Archaeological Science* 41(1): 106–132. <https://doi.org/10.1016/j.jas.2013.07.018>

- Milcent, P.-Y. 2017. Valeurs d'usage et d'échange. La dimension prémonétaire des dépôts en Gaule atlantique du XIIIe au Ve s. av. J.-C. *Bulletin de la Société préhistorique française* 114(4): 711–737.
- Oldeberg, A. 1927. Ett smedfynd i Ystad från yngre bronsåldern. *Fornvännen* 22: 107–121.
- . 1928. Ett bronsåldersfynd från Hjärpetan i Värmland. *Fornvännen* 23: 321–345.
- . 1929. “Bräckanfyndet” - ett gjutfynd från bronsålderns fjärde period. *RIG: Föreningens för svensk kulturbistoria tidskrift* 12: 37–48.
- . 1934. Två bronsåldersfynd från Åsle socken i Västergötland. *Västergötlands fornminnesförenings tidskrift* 4(7–8): 9–42.
- Rezi, B. 2011. Voluntary destruction and fragmentation in Late Bronze Age hoards from central Transylvania. In: S. Berecki et al. (eds) *Bronze Age rites and rituals in the Carpathian Basin: proceedings of the international colloquium from Targu Mures 8–10 October 2010*. Târgu Mureş: Editura Mega, 303–334.
- Röst, A. 2016. *Fragmenterade platser, ting och människor: stenkonstruktioner och depositioner på två gravfältlokaler i Södermanland ca 1000–300 f.Kr.* Stockholm: Stockholm University.
- Rundkvist, M. 2015. *In the landscape and between worlds: Bronze Age deposition sites around lakes Mälaren and Hjälmaren in Sweden*. Umeå: Umeå University.
- Sörman, A. 2018. *Gjutningens arenor: metallhantverkets rumsliga, sociala och politiska organisation i södra Skandinavien under bronsåldern*. Stockholm: Stockholm University.
- . 2023. *Inventory of five Swedish Late Bronze Age ‘scrap hoards’* [Innehållet i fem svenska “skrotdepåer” från yngre bronsålder]. Available at: <https://doi.org/10.58141/5x6w-mx80>.
- Thedéen, S. 2004. *Gränser i livet – gränser i landskapet: generationsrelationer och rituella praktiker i södermanländska bronsålderslandskap*. Stockholm: Stockholm University.
- Thrane, H. 1975. *Europæiske forbindelser: bidrag til studiet af fremmede forbindelser i Danmarks yngre bronsalder (periode IV-V)*. Copenhagen: Nationalmuseum.
- Weiler, E. 1996. Metal standard during the Bronze Age. *Lund Archaeological Review* 2: 17–30.

# 17

## A MAN-OF-WAR IN PIECES

### Fragmenting the *Rikswasa* of 1599

*Mirja Arnshav*

#### A devastated wreck

At first, you hardly see anything but the greenish water surrounding you. But as you follow the gently sloping seabed downward, round ballast stones and timbers can be discerned. And then, at a depth of six metres, more and more pieces of timber come into sight – the remains of the naval ship *Rikswasa*, which sank after a fire accident in 1623.

The Baltic Sea does not provide the best conditions for scuba diving. It is cold and dark, with turbid waters and a species-poor ecosystem. Nonetheless, it does have one great advantage: due to a unique combination of water quality and the absence of wood-consuming organisms, historic shipwrecks are exceptionally well preserved and can stay more or less intact for several hundreds of years. And as the remains are often uncovered, they are easily explored by anyone with a scuba diving licence.

When the *Rikswasa* was launched in 1599, it was one of the largest ships in the Swedish navy, measuring about 45 m in length (Glete 2009:37). The hull was constructed of tonnes of strong oak timbers, fitted together with bolts and framings to form a hull that would resist stormy seas as well as attacks from enemies. Given this, and also the excellent preservation conditions of the brackish water, you would expect large parts of the massive ship to be preserved, with the exception of the parts of the hull that were consumed by the fire. However, on the sea floor, only a fraction of the ship is left, mostly in fragments. What has happened to the wreck? Where have all the missing parts gone?

These strange absences reflect a unique story of purposeful fragmentation. In the 1960s, large amounts of ship timber from the *Rikswasa* were salvaged

and turned into memorabilia, artefacts and furniture, until it was forbidden by the Swedish Antiquity Act in 1967. How was this fragmentation carried out and motivated? What ideas, traditions and interests underpinned it, and what was the criticism?

As an example of deliberate fragmentation in the recent past and in our own cultural context, the case of the *Rikswasa* adds to the long history of archaeologically established fragmentation practices. It illustrates how fragmentation can be a way of engaging with the past and helps us recognise that the present authorised heritage discourse should not be seen as timeless or without alternatives.

### 100 years of wreck oak salvage

In Swedish waters, there is a long tradition of recovering ships and cargo lost at sea. From the 17th century on, expert salvors were recurrently supported by the kingship and the navy, who were eager to regain some of the precious materials so that they could be sold or reused. During the second half of the 19th century, helmet diving became more common, and the old wrecks started to attract attention that did not only have to do with financial interests. The increasing diving activities spurred a more general interest in naval antiquities, which was further fuelled by the high social status of naval officers in contemporary society and the emerging bourgeois' nostalgic interest in the history of the nation (Cederlund 1983; Cederlund & Hocker 2006).

In the late 1860s, the burgeoning interest in old wrecks found a new expression: waterlogged oak wood. In 1867, an old man-of-war, *Nya Riga*, was recovered in Karlskrona roadstead, where it had foundered in the 18th century. This time, the salvors were not solely interested in retrieving ship timbers for reconstruction and showcasing purposes but also in paying homage to naval history. To a greater extent, the timbers were now reworked into boxes, letter openers, etc. The material had a unique life history, and to underline the royal connections, the king of Sweden received an entire suite of furniture made out of wrecked wood from *Nya Riga* (Cederlund 1983:37).

In the following decades, up to the 1920s, an additional number of ambitious salvage projects for the manufacture of furniture and memorabilia were carried out at naval wreck sites. Similar projects took place in the eastern and southern Baltic countries, especially in Finland, but not as frequently as in Sweden. One of the most extensive projects was carried out in 1916 in the city of Karlskrona and was sparked by the finding of the wreck of *Småland*, a naval ship sunk in 1730. The promotor, a marine engineer, had the wreck dismantled so that more than 20 tonnes of wood could be sawn to pieces for future processing (Ohlsson n.d.).

In fine carpentry, the use of waterlogged oak was not new, but up until then it was mainly found in bogs. It was widely known that, as a result of

the special preservation under water, the chemistry of such oak had changed so that over time it turned harder and darker. As the transformation process took hundreds of years, these clearly perceptible properties of the wood also made manifest a more subtle quality: its great age. The material was appreciated for being beautiful, rare and exclusive and was used for souvenir production, furniture making and interior decorations of affluent 19th-century homes (Cederlund 1983:37–38; HC archive).

Bringing the waterlogged oak wood of historic wrecks into focus made a far wider number of wreck sites potentially profitable. Although it was seldom as aged as bog oak, the wreck wood's link to past societies was much stronger and fitted well into the growing interest in naval history. Consequently, when waterlogged oak from wrecks was introduced, a new quality was added to the material: an exciting provenance. The wood being part of a wreck raised from the sea floor made it stand out as spectacular, and the life history of the actual ships made it even more special. This opened up for the selection of specific pasts, with a preference for dramatic episodes and glory days in the nation's naval history. For the most part, the salvors targeted wreck sites associated with the sailing fleet of the 17th and 18th centuries – ships that were also known to be big, built of oak and whose histories and sinking sites were comparatively easy to track down in archives.

A contributing factor to the market for waterlogged oak in the late 19th and early 20th centuries was contemporary style preferences. Materialising the past, the oak fitted well with the historicism in architecture and design. Its characteristic dark nuance, robust texture and aura of great deeds made it especially associated with masculine styles such as the new Renaissance, designated for men's rooms and furniture, as well as prominent buildings. Its marine origin made it suitable for decorative items in naval contexts, and it also figured in churches in the shape of crucifixes and baptismal fonts. In the daily press of the early 20th century, adverts from sellers of 'black oak' from wrecks were recurrent, announcing that furniture made of the precious material was available for sale or that the wood could be bought in bulk (NLS archive).

In spite of an increased interest in waterlogged oak material and better opportunities for collecting it, this never became a large-scale industry. Salvage projects were costly to carry out, and the market was quite easily flooded. Also, in contrast to bog oak, most wrecked timbers turned out to be full of nails and bolts that made them unfit for carpentry. On top of that, due to the breakthrough of functionalism, wood of a lighter colour came into fashion. Hence, considerable quantities of the oak that were salvaged during the different pioneering campaigns were eventually discarded. In 1967, an addendum to the Antiquities Act criminalised all intrusive operations at historic wreck sites, such as black oak salvage (Arnshav 2011:39–43; Norman 2022:16–28). A century-long era of commercial oak salvage from wrecks

was coming to an end. But one last major salvage operation was still to be carried out: the recovery of the *Rikswasa*.

### Salvaging the *Rikswasa*

The building of the *Rikswasa* started at a shipyard in Lake Mälaren, some 50 km west of Stockholm, in 1597 and was finished at the royal shipyard in Stockholm in 1599. The ship was built by the English shipwright Tomas Walter to serve as a command ship but was later rebuilt and degraded into a third-rate ship (Glete 2009:36–37).

The wreckage was due to a fire accident caused by the crew. In 1623, the *Rikswasa* and several other naval ships had anchored some 35 km east of Stockholm. Their mission was to block the sea route to Stockholm when the Polish fleet was expected. In October, after months of waiting, a fire broke out onboard. After it had reached the gunpowder kegs, it was impossible to stop. In order to prevent the fire spreading to the other ships and to facilitate later salvage work, the burning ship was towed towards the shore, where it sank. A few years later, salvage operations were carried out at the site, and at least 12 guns and the main mast were recovered (Glete 2009:36–37).

For centuries to come, the wreck of the *Rikswasa* was left on the sloping sea floor. The shallower parts of the wreck were partly discernible in the water, and the locals were not ignorant of it (SMR archive: 6143:3). The shore and the house property closest to the wreck were called *Brännskäret* (Eng. The scorched islet), and stories about the sunken ship were passed on by word of mouth. In the early 20th century, it was either assumed to be an old Swedish naval ship or a Russian naval ship that exploded during the Russian pillage of 1719 (ISOF archive). A salvage company informed about the foundering of the *Rikswasa* in the area made plans to approach the wreck in 1922 but never proceeded (Randall 2013:38–39).

After the aqualung hit the market in the mid-20th century, the wreck was occasionally explored by scuba divers, of whom at least some were aware of its identity. In the late 1950s, a diving group interested in maritime history salvaged the rudder and the transom, as well as a number of cannonballs. Some of the cannonballs were sold or put on display at local museums, while the transom and the rudder ended up as garden decorations. This was after the owner's suggestion to place it in central Stockholm as a monument for commemoration of the former royal shipyard was turned down by the city's officials (SMR archive).

In 1956, a uniquely well preserved and richly ornamented early 17th-century naval ship, the *Vasa*, was found in Stockholm harbour. The ship had sunk on its maiden voyage and enclosed more than 40,000 objects from contemporary society. The find and the preparations for the pioneering salvage gained a lot of media attention and sparked a wide public interest

in underwater heritage and naval history. The recovery was followed by a ground-breaking excavation and preservation project (Cederlund & Hocker 2006). Today, the Vasa Museum is an important tourist attraction, with about 1.5 million visitors annually.

Inspired by the commotion around the *Vasa*, two brothers who ran a scuba diving and carpentry business had the idea of taking up the, by then, rather dormant business of wreck wood salvage, and their target was the *Riksvasa*. They had learned about the position of the wreck and were also aware of the fact that it had been ravaged by fire and, to some extent, also by scuba divers. The brothers assumed that the wreck was inapt as a source for archaeological knowledge and public mediation and hence lent itself to alternative approaches (SMR archive). The Swedish Antiquities Act did not yet provide protection for ancient wrecks, so it was perfectly legal to salvage timber from wreck sites (Norman 2022:13–28).

In the early 1960s, the brothers started to explore the site. No proper documentation of the process exists, but contemporary statements in the press indicate that they started off by recovering artefacts, such as cannonballs and loose timbers. Thereafter, they broke the remains of the deck in order to get access to the inner hull; they removed ballast stones and used a dredge to remove sediments as preparation for the salvage (Andersson 1964; Andersson 1965:14–17; Widding 1965; Wahlöö 1969:28–29).

The breaking and lifting were mainly done during the winter with the help of a tree stump lifter placed on the ice. During the summer, a boat with a crane was employed. The following year, a large pontoon and a giant crane were hired for the final lifts. The media were once again invited to witness the event, and this time large sections of the hull were brought ashore (AFC archive; Tore 1965; Figure 17.1).

Considering the recent and carefully planned raising of the *Vasa* and the great effort that was put into the archaeological excavation and preservation work that followed, the rough treatment of the *Riksvasa* stands out as a striking contrast. But unlike the *Vasa* project, the goal was not to preserve the hull as completely as possible to reconstruct an intact early 17th-century ship but rather to upcycle the individual timbers of the hull. The procedure for salvaging *Riksvasa*'s hull parts did indeed become more and more incautious as a new heritage policy on wreck protection was on its way to being authorised, making the whole project turn into a race against time.

Still, although it was perfectly legal to salvage the *Riksvasa*, not everybody was happy about it. Locals living close to the wreck site wrote to the authorities and expressed the opinion that the wreck was an appreciated part of the neighbourhood and ought to be left as it was, to be enjoyed by the community and by careful scuba divers, at least until the time came when it could contribute to historical knowledge and be explored by professional archaeologists. In addition, they were also disappointed with the salvors'



**FIGURE 17.1** A large section of the bottom part of *Rikswasa's* hull was raised in the mid-1960s. It was then fragmented for the production of furniture, gadgets and memorabilia (photo: Jonas Berg, courtesy of National Maritime and Transport Museums, CC BY-SA).

choice to erect a tomb-like stone by the shore for commemorating the wreck, as they had preferred a memorial made out of original wreck timbers (SMR archive).

The heritage sector, on the other hand, did not so much oppose the ongoing salvage project as such but was more worried about the fragmentation and commodification of the remains and, above all, the lack of control. The ship timbers came in useful as comparison material for the ongoing reconstruction of the *Vasa*, and the heritage sector wished to have them properly documented. However, the *Vasa* project had already resulted in a great deal of cost and effort for all parties involved, not least the taxpayers, and trained underwater archaeologists did not yet exist. For the foreseeable future, there will simply be no capacity for the heritage sector to lead additional salvage projects (Norman 2002:26; SMR archive).

The solution was to cooperate with the salvors. It was agreed that the Maritime Museum, from now on, would be given the opportunity to document

all recovered ship parts and incorporate finds of historical interest into their collections. This resulted in a handful of construction drawings, photo documentation of several ship parts and 25 collected artefacts (Arnshav 2011:39–44; SMR archive).

Meanwhile, work on developing proper legal protection for wrecks was intensified in order to slow down private exploration and gain control over the scuba diving situation. In 1967, an addendum to the Antiquities Act was implemented, popularly referred to as ‘lex Nahlin’ after the brothers who ran the salvage business at the *Rikswasa* wreck site. It stated that shipwrecks that had sunk more than 100 years ago were to be considered ancient remains and that it was forbidden to dislodge, remove, excavate, cover, or in any other way alter or damage them (Arnshav 2011:39–44, Norman 2022:16–22). Hence, an *in situ* policy that included remains on the sea floor had finally prevailed. Thereby, further recovery at the *Rikswasa* wreck site was halted, as was future commercial wreck wood salvaging.

### Fragments for sale

There is growing evidence from many past cultures that objects, and even bodies, have recurrently and deliberately been disarticulated in order to create special fragments; these have subsequently been worked, circulated or deposited for reasons having to do with relations, identity and memory (Chapman 2000; Chapman & Gaydarska 2007; Brittain & Harris 2010; Rebay-Salisbury et al. 2010; Brück 2016; Frie 2020). The phenomenon seems to be well spread across the world and throughout history. Acknowledging this circumstance has without doubt enriched the archaeological understanding of past cultures and the many ways in which material culture defines relations and societies. However, deliberate acts of breakage and circulation of fragments in our own time and present sphere of culture have rarely been archaeologically studied.

The *Rikswasa* was deliberately broken in the early 1960s in order to facilitate salvage of the timbers and hull sections. Thereafter, the parts were further worked and circulated in a similar way as has been found to be characteristic in past contexts in which fragments have been considered significant. Some timbers, like pieces of deck beams, frame tops or beautifully eroded planks, were simply sawn into stumps and marked with a small metal plaque stating that the artefact was made of ‘black oak’ from the *Rikswasa* and salvaged by the Nahlin brothers. In other cases, elements – often brass items with a nautical touch such as lamps, clocks or barometers – were mounted on a gently polished timber stump. Some furniture was also manufactured, like a bar table for the Shah of Persia. A well-known restaurant run in a building with historical links to one of the commanders of the ship bought large quantities of wood for furnishing a bar. A shipping company had the dining room of

one of their ships fitted up with eroded pieces of wreck timber, together with illustrations of the *Rikswasa*'s past (AFC archive; NLS archive; SMR archive; Wiklund 2013; Figure17.2).

Needless to say, the main reasons for dismantling wrecks and circulating the waterlogged oak wood were always commercial. The salvors of the *Rikswasa* ran a gallery in the city centre of Stockholm in which items made of wrecked wood, such as cutlery, salt and pepper mills, beer taps, whisky racks, cigarette lighters and ashtrays, were put on display and sold. Advertisements were also published by the brothers in newspapers, offering larger quantities of wood for sale. They regularly invited the press to follow their endeavour (a short documentary film about the 'diving adventure' was even produced by a Swedish director known for contemporary feature film thrillers), resulting in a number of articles in popular magazines with a predominantly male audience. A narrative was formed about the exclusiveness of the wreck wood, the great value of it, and the entrepreneurship of the salvors. Similarly, the media did not forget that several royalties and other celebrities had been given or had bought items made of *Rikswasa* wood (AFC archive; Andersson 1965).



**FIGURE 17.2** The parts of *Rikswasa* keep circulating. In 2022 this clock was sold for c. 90 euros. The brass plaque states that the wood is a deck beam from the *Rikswasa*, built in Stockholm in 1599, foundered in 1623 and salvaged by the Nahlin brothers in 1962 (photo: Anders Båge Wahlström, Höganäs auktionsbyrå).

In the carpentry industry, hopes were occasionally put forward that waterlogged oak could be a domestic alternative to mahogany and other dark-coloured tropical kinds of hardwood, which were again fashionable in the 1960s. Nevertheless, as it seems, the whole basis for commodifying oak from old wrecks was not only a matter of the colour and properties of the wood but also a fascination for its historical qualities and its submarine past, to which the dark colour testified. In other words, the black colour was not primarily appreciated because of aesthetic reasons but rather because of its intrinsic values and affectiveness. The black oak brought the past into focus and added place-value by grounding it in a precise site and the specific life history of a ship.

When fragmented, the mnemonic wood acquired even more meaning. The artefacts, which were all marked or sold with a certificate declaring that they were pieces of the *Rikswasa*, were loaded with generic references to sinking ships, ship wreck explorations and hidden treasures. And when coupled with nautical objects or pieces of coral or turned into household artefacts associated with predominantly male users, further references were added.

In sales brochures and statements in the press, the salvors' framing of the *Rikswasa* products was plain: the wood provided a link to a royal ship dating from the nation's great power era (SMR archive). As one of the brothers explained in an interview, besides making money, the goal was to offer people an experience of the past in a direct and affective way. By means of the fragmented ship timbers, the salvors provided people with a chance to hold a piece of 17th-century history in their hands, display it in their homes, and experience it together with friends and relatives (Andersson 1964).

In addition, the salvors stressed that by selling their *Rikswasa* artefacts in a kiosk next to the preliminary *Vasa* Museum, tourists would stop vandalising the *Vasa* by cutting fragments out of the hull and instead buy a beautiful souvenir made of its predecessor and namesake. There were even plans to sell the *Rikswasa* fragments in the souvenir shop of the *Vasa* Museum so that the full public potential of the *Vasa* – a whole ship wreck – and the *Rikswasa* – a fragmented ship wreck – could complement each other (Andersson 1964).

In the minds of the salvors the fragmentation of the wreck was not merely a destructive process, but instead a cultural achievement. It was a way of activating a dormant ship and a means of sharing history by reaching out to a non-diving community. It is noteworthy that these ideas about offering links to history were launched in a particular period in Sweden that has been described as extremely future-oriented and in which interest in the past was declining. Promotion of history related to kings, nations and the great power era was definitely not at the top of the agenda of professional historians and the heritage sector (Grundberg 2004). In that regard, the *Rikswasa* fragments can be understood as reifications of an unscholarly interest in history. Just like traditions in Nordic folklore suggested that the recycling of timber could

result in the transplanting of household spirits, it is reasonable to assume that the logic underpinning the fragmentation also draws on an acknowledgement of a more animistic and relational approach to old buildings and ships in contrast to modern objectification (Herva 2015).

### Fragmented heritage and the heritage of fragmentation

It has been pointed out that the discipline of archaeology is strongly influenced by a contemporary ‘culture of wholes’, meaning that there is a strong tendency in the modern western world to emphasise and idealise what is whole in the sense of being original, intact and unchanged. Accordingly, archaeologists recurrently tend to associate bits and pieces with loss, indicating that something has gone missing or is simply wasted. Confronted with a fragment, most archaeologists immediately turn to reconstructions and thoughts on what the piece originally used to be (Chapman & Gaydarska 2007; Brittain & Harris 2010:589; Burström 2013).

This preference for wholes has clearly had an influence on the approach to the *Rikswasa* wreck site. In the early 1960s, the wreck was ruled out as being of no or low archaeological interest because it was not as intact as the *Vasa* (although in international comparison it was remarkably well preserved). Obviously, more emphasis was put on the damage in relation to the fire in 1623 than on the unique preservation qualities of the Baltic Sea. After the events in the 1960s, the wreck site was generally dismissed as messed up or devoid of content. Among archaeologists, the incident was bewailed and often referred to as a tragedy and blot in the history of underwater heritage management (Arnshav 2011:39–44; Wiklund 2013:13; Norman 2022:13).

If it were not for the extremely improbable but successful *Vasa* project, history’s judgement of the handling of the *Rikswasa* may not have been equally harsh. But there are also reasons of even greater significance that go far beyond the management of cultural heritage under water and the Swedish situation. The salvage of the *Rikswasa* took place during a period of time when underwater archaeology (and historical archaeology) was starting to become professionalised and saw a rapid shift in emphasis from collecting cultural relics for museum displays to *in situ* conservation. A century-long tradition of private commercial wreck oak salvaging was about to come to an end for the benefit of a preservation paradigm, which today is generally accepted and promoted by influential organisations like UNESCO and ICOMOS as well as legislation in most economically developed countries (Brattli 2009; Burström 2009; ICOMOS 1990).

In the paper *Heritage of Heritage*, archaeologist Cornelis Holtorf (2012) points out that every heritage discourse is firmly situated in a specific historical and cultural context and that much of what we take for granted regarding heritage and preservation is bound up with a very particular way of

thinking, disposed to a “sacredness of cultural heritage” (Holtorf 2012:159 citing Beckman 1998:32–39). He discusses how the contemporary heritage discourse is strongly focused on, even obsessed with, conservation, preservation and protection, and he stresses that this “curious peculiarity of our age” (Holtorf 2012:160) has taken over nearly the entire range of legitimate ways of being interested in the past. Finally, he questions what people a century from now will be able to learn about us from studying presently curated heritage sites. What will the traces of our management approach look like? Will the preservationist paradigm unfold, and if so, how will this be understood (Holtorf 2012)?

The past in the past is an interesting subject that has gained considerable archaeological attention. It has been established that many prehistoric cultures show a strong interest in historic artefacts and monuments (Bradley 2002), and that such engagement with the past has sometimes involved the disarticulation of ancient remains and the circulation of mnemonic fragments (Chapman 2000). Most often, the use of the past has been linked to elite groups (Jensen 2002; Lund & Arwill-Nordbladh 2016; Lund 2017). But the phenomenon as such – to relate to history and engage with its materiality in one way or another – is a basic human condition (Schnapp 1996).

What kind of footprint did past salvage activities at the *Rikswasa* wreck site leave? Unfortunately, there is no documentation of what the wreck site looked like before the arrival of the black oak salvors. Nonetheless, by studying the files of the Maritime Museum and scrutinising the identifiable pieces of timber that were put up for sale, a rough understanding of the salvors’ impact on the wreck site can be gained. It can be concluded that in addition to the stern parts and the rudder that were recovered as early as the 1950s, a large section of the bottom of the hull, a somewhat smaller part of the port side of the hull and many of the deck planks, frames, beams and other timbers were removed from the site (SMR archive).

After the final lifts in 1966, the wreck was seldom visited by divers, as it was widely dismissed as totally destroyed and mostly gone. Left on the site was a remaining part of the hull bottom, covered by a heap of loose timbers, scattered ballast stones, some tiles and pieces of rope, and wires that the salvors had strewn around (Cederlund 1983:224; SMR archive).

When revisited a little more than 40 years later, no further changes were observed. Here and there, nails are sticking out of the frames, reflecting the fact that beams, inner planking and structures have been removed by force. There are no signs of saw cuts in the timbers, which confirms that the wreck was mainly broken by using slings, straps and lifts. Other remains of the salvage events were a cable and ropes, as well as the many ballast stones that were found sprinkled over the sea floor. Most notable, however, is the mess of thousands of loose stumps of timbers. This bears no resemblance to natural fragmentation processes but reveals which wreck parts were rejected; it mirrors the selection process and perhaps also the efforts to clear and lighten

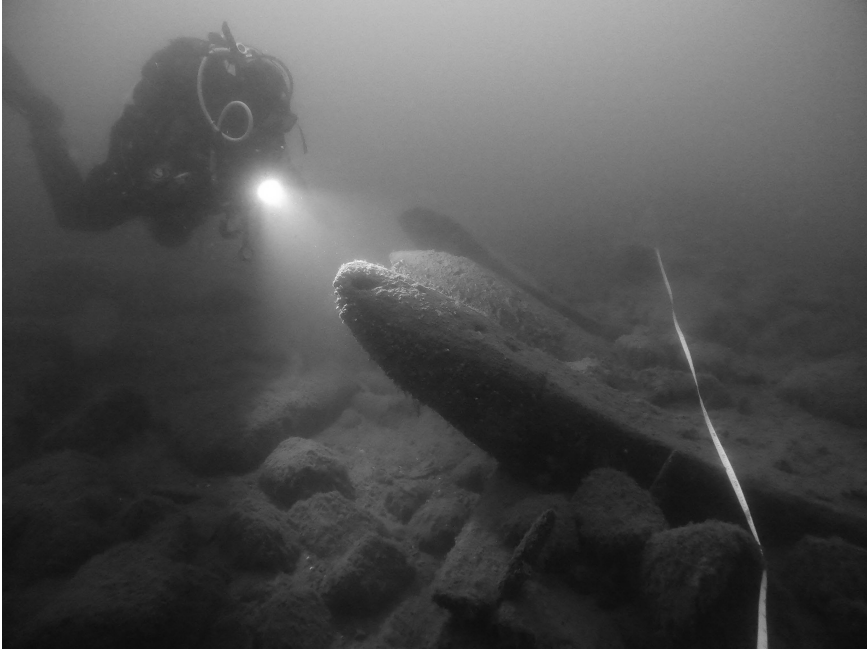

**FIGURE 17.3** At the wreck site, the evidence of the breaking is evident. The most intact part of the remaining hull is slightly submerged into the sea floor and covered by loose pieces of timber (photo: Niklas Eriksson).

certain sections of the hull as a preparation for lifting them out of the water. The site formation process is in many ways complicated but has great potential, if surveyed in greater detail, to provide information about the salvors' selection and course of action (Figure 17.3).

### **A new understanding**

To anyone interested in the construction of early 17th-century naval ships, and life on board, the interference of the oak salvors is indeed a serious violation of the wreck site. But what if we instead approach it from another angle, regarding it as an iconic site in the history of maritime cultural heritage management and as a representative of a unique tradition of oak salvaging, of which we still have much to learn? In that case, the very destruction, including all the material spoils of the salvors, along with the striking absences they caused, are telling evidence of the way in which the past was consumed by oak salvors, traders and buyers. It can be argued that the traces of salvage at the wreck site form a heritage in themselves. In addition, the history of *Rikswasa* can help us reflect on current heritage paradigms and, at the same time, help remind us that this is by no means universal or without alternatives.

On that note, the history of the fragmentation of the *Rikswasa* forms an interesting example of a popular approach to history, of an elite (of professional heritage managers and archaeologists) taking control over the past, and how a new heritage paradigm spreads while contradictory approaches are shunned and even criminalised. In many ways, the destruction of the *Rikswasa* marks a turning point in Swedish maritime heritage management. An end has been put to further salvage operations, but the allure of wreck oak is by no means extinct. At auctions, antique shops and internet auction sites, fragments of the *Rikswasa* and other wrecks keep circulating, like material memories of powerful ships and of the devoted salvors that brought them to pieces.

When considering what kind of artefacts were made from the fragmented ship, much can be learned about how the *Rikswasa* wreck was perceived by the salvors and their customers. The artefacts clearly reflect a contemporary fascination with old, naval ship wrecks, also revealing how these were closely linked to adventure, masculinity and the wider nautical and submarine sphere. As is often the case with material culture, they also had a part to play in manifesting and negotiating their owner's identity. They were exclusive but not expensive, and they were not controlled by the elite but rather by specialists and people from the broad layers of society.

Approaching them as fragments brings us a deeper understanding. It makes us aware of the very materiality of the wood and how the fragments are relational and link people to distant places and past events and periods. A strong appreciation of authenticity is present here, but not in terms of original forms and functions but in terms of the wood itself, as a matter with a kind of soul and animated by past experiences (see Herva 2015). This is also expressive of a non-scholarly take on the past and ancient remains. Altogether, the pieces of *Rikswasa* point towards fragments as something more than just pieces of a former whole. They are new objects in their own right, and fragmentation enabled their transformation. Hence, fragmentation is not the end but rather the beginning, blazing new paths and enabling a diversity of possible trajectories for single composite things, like a ship.

## References

- Andersson, R. 1964. Titta vad jag har hittat! *SE*, November 10.  
 ———. 1965. Gör som jag – bli miljonär på ett VRÅK. *FIB Aktuellt*, January 26: 14–17.
- Arnshav, M. 2011. "Yngre vrak". *Samtidsarkeologiska perspektiv på ett nytt kulturarv*. Huddinge: Södertörns högskola.
- Beckman, S. 1998. Vad vill staten med kulturarvet? In: A. Alzén & H. Hedrén (eds) *Kulturarvets natur*. Stockholm: Symposium, 13–49.
- Bradley, R. 2002. *The past in prehistoric societies*. London: Routledge.

- Brattli, T. 2009. Managing the archaeological world cultural heritage: consensus or rhetoric? *Norwegian Archaeological Review* 1(42): 24–39. <https://doi.org/10.1080/00293650902904505>
- Brittain, M. & Harris, O. 2010. Enchaining arguments and fragmenting assumptions: reconsidering the fragmentation debate in archaeology. *World Archaeology* 42(4): 581–594. <https://doi.org/10.1080/00438243.2010.518415>
- Brück, J. 2016. Hoards, fragmentation and exchange in the European Bronze Age. In: S. Hansen et al. (eds) *Raum, Gabe und Erinnerung: Weihgaben und Heiligtümer in prähistorischen und antiken Gesellschaften*. Berlin: Topoi, 75–92.
- Burström, M. 2009. Heritage management and the end of history. Comments on Terje Brattli: ‘Managing the archaeological world cultural heritage: consensus or Rhetoric?’. *Norwegian Archaeological Review* 2(42): 183–186. <https://doi.org/10.1080/00293650903354262>
- . 2013. Fragments as something more: archaeological experience and reflection. In: A. González Ruibal (ed.) *Reclaiming archaeology: beyond the tropes of modernity*. Milton Park, Abingdon: Routledge, 311–322.
- Cederlund, C.O. 1983. *The old wrecks of the Baltic Sea: archaeological recording of the wrecks of carvel-built ships*. Stockholm: Stockholm University.
- Cederlund, C.O. & Hocker, F. 2006. *Vasa 1: the archaeology of a Swedish warship of 1628*. Stockholm: Statens maritima museer.
- Chapman, J. 2000. *Fragmentation in archaeology: people, places, and broken objects in the prehistory of south-eastern Europe*. London: Routledge. <https://doi.org/10.4324/9780203759431>
- Chapman, J. & Gaydarska, B. 2007. *Parts and wholes: fragmentation in prehistoric context*. Oxford: Oxbow Books.
- Frie, A.C. 2020. Parts and wholes: the Role of animals in the performance of Dolenjska Hallstatt funerary rites. *Arts* 2(9): 53. <https://doi.org/10.3390/arts9020053>
- Glete, J. 2009. Flottor och örlogsskepp i Djurhamn. In: K. Schoerner (ed.) *Skärgård och örlog. Nedslag I Stockholm skärgårds tidiga historia*. Gustavsberg: Kulturnämnden, Värmdö kommun, 29–40.
- Grundberg, J. 2004. *Historiebruk, globalisering och kulturarvsförvaltning: utveckling eller konflikt?* Gothenburg: Gothenburg University.
- Herva, V-P. 2015. Buildings as persons: relationality and the life of buildings in a northern periphery of early modern Sweden. *Antiquity* 84(324): 440–452.
- Holtorf, C. 2012. The heritage of heritage. *Heritage & Society* 5(2): 153–174. <https://doi.org/10.1179/hso.2012.5.2.153>
- ICOMOS. 1990. Charter for the protection and management of the archaeological heritage [online]. [https://www.icomos.org/images/DOCUMENTS/Charters/arch\\_e.pdf](https://www.icomos.org/images/DOCUMENTS/Charters/arch_e.pdf) [Accessed 26 November 2022].
- Jensen, O.W. 2002. *Fortid i historien: en arkeologihistorisk studie av synen på fortid och forntida lämningar, från medeltiden till och med förupplýsningen*. Göteborg: Göteborgs Universitet.
- Lund, J. 2017. Connectedness with things. Animated objects of Viking Age Scandinavia and in early medieval Europe. *Archaeological Dialogues* 24(1): 89–108. <https://doi.org/10.1017/S1380203817000058>
- Lund, J. & Arwill-Nordbladh, E. 2016. Divergent ways of relating to the past in the Viking Age. *European Journal of Archaeology* 19(3): 415–438. <https://doi.org/10.1080/14619571.2016.1193979>

- Norman, P. 2022. *Marinarkeologins förvaltningshistoria. Den centrala marinarkeologiska förvaltningens utveckling i Sverige 1960–2019* [online]. Rapport 3. Havsmiljöinstitutet. [https://havsmiljoinstitutet.se/digitalAssets/1806/1806301\\_rapport-marinarkeologisk-f--rvaltningshistoria\\_slutlig-version.pdf](https://havsmiljoinstitutet.se/digitalAssets/1806/1806301_rapport-marinarkeologisk-f--rvaltningshistoria_slutlig-version.pdf) [Accessed 26 August 2022].
- Ohlsson, T. [n.d.] *Ett skrivbord med historia* [online]. <https://www.koms.se/ett-skrivbord-med-historia/> [Accessed 26 August 2022].
- Randall, L. 2013. *Bärgningar – Regalskepp – Vasa: Olschanskis öden*. Ingarö: Lorelei Randall.
- Rebay-Salisbury, K. et al. eds. 2010. *Body parts and bodies whole: changing relations and meanings*. Oxford: Oxbow Books.
- Schnapp, A. 1996. *The discovery of the past: the origins of archaeology*. London: British Museum.
- Tore. 1965. Minnessten över “Rikswasa” men skeppet behöll sin akter. *Dagens nyheter*, May 8.
- Wahlöö, I. 1969. Skatter under havsytan. *Hemmets veckotidning* 41: 28–29.
- Widding, L. 1965. Kanonkulor resultat av “vrakplundring”. *Dagens nyheter*, January 28.
- Wiklund, J. 2013. Rikswasa – från örlogsskepp till askfat. *Marinarkeologisk tidskrift* 1: 10–13.

## Archives

- AFC, The Archival Film Collections of the Swedish Film Institute, Stockholm.
- Axelmann, T. 1969 *Bärgningen av Rikswasa – ett dykaräventyr*. <https://www.filmarkivet.se/movies/bargningen-av-rikswasa-ett-dykaraventyr/> [Accessed 26 August 2022].
- HC, The Hallwyl Collection  
Catalogue 1, 180.
- ISOE, Swedish Institute for Language and Folklore, Uppsala.  
The place name register, no 1958028.  
<https://ortnamnsregistret.isof.se/place-names> [Accessed 26 August 2022].
- SMR, The Swedish Maritime Archaeological Register at the Maritime Museum, Stockholm.  
Rikswasa 6143:3.
- NLS, The National Library of Sweden, Stockholm.
- The Newspaper Archive, search word ‘Rikswasa’, ‘svartek’, ‘sjödränkt ek’.  
<https://tidningar.kb.se/> [Accessed 26 August 2022].

# 18

## FRAGMENTATION RESEARCH AND THE FETISHISATION OF INDEPENDENCE

*John Chapman*

The process of life is marked by the continuous creation of wholes from parts.\*

(Alexander 1979)

### Introduction

In Madeleine Bunting's (2021) review of Kate Mosse's book 'An extra pair of hands: a story of caring, ageing and everyday acts of love', Bunting explains the author's questioning of '... how and why we fetishise independence when the reality of human experience is always interdependence'. Mosse's insight chimes well with the general aim of the fragmentation project as it has been advancing over the last quarter-century: a search for connections between people, places and objects. Working in parallel to the recent 'new materialist' insistence on connections (viz. everything is related to everything else: (DeLanda 2016; Harman 2018) and acting as an early contribution to 'relational ontologies' (Alberti et al. 2016; Hamilakis & Jones 2017; Cambridge Archaeological Journal 2021), fragmentation studies developed and retained a distinctive view of material by asserting relations of enchainment based upon people moving fragments across the landscape and around the site. These relationships prioritised the meaningful ways by which human and non-human agents created themselves through their connections (viz., relational ontology)<sup>1</sup> and emphasised the interdependence of those relationships. In my view, it is futile to reify the independent agency of the arrowhead, the tree or the aurochs when the key point was their interdependence with humans. As Victoria Coren Mitchell<sup>2</sup> would put it, 'only connect ....'.

\* Alexander, C. 1979. *The Timeless Way of Building*. New York: Oxford University Press, 31. Reproduced with permission of the Licensor through PLSclear.

In this chapter, I have four aims. First, I set the scene by presenting some of the key moments in the development of fragmentation studies. Second, I re-establish the importance of place by inserting the notion of ‘landscape fragmentation’ into the relational identity triangle. Accomplishing this allows me to pursue the third aim of identifying the implications of a recent turn in fragmentation studies – the turn towards multiple entities. And, fourth, I seek to extend the idea of ‘multiple objects’ to discuss multiple places and persons as well. In the discussion, I seek to connect these four fragments of the same picture through a consideration of relational identities.

### Points along the itinerary of fragmentation studies

Although archaeologists have long recognised the fragmentary nature of objects in the past (Lucas 2015), the earliest recognition of deliberate object fragmentation occurred, as far as I know, almost a century ago, in Dumitrescu’s (1927–1932) account of figurine breakage. Few social insights into fragmentation appeared in that century (but note Talalay 1987) and it was not until 2000 that the deliberate breakage of persons and objects was set in an overall social context (Chapman 2000) (for a short history of fragmentation research, see Chapman 2022). An important stage in this research concerned the definition of the so-called Fragmentation Premise. In the earlier version, which prioritised people and objects, we proposed that *objects were regularly deliberately fragmented, and the resulting fragments were often re-used in an extended use-life ‘after the break’* (Chapman & Gaydarska 2007: 2, 8–10, 18). However, this version of the premise ironically left fragmentation theory incomplete – lacking a grounding in the places that constituted the sources of material in the wider landscape (see below, pp. 291–3).

Turning to matters of theory and method, critical comments in the 21st century focussing on fragmentation theory (e.g. Jones 2005; Fowler 2008; Brittain & Harris 2010) and methodology (e.g. Bailey 2001; Milisauskas 2002) have done little to stem the expanding tide of case studies demonstrating deliberate breakage and re-use of broken parts for a wide variety of materials and object types in an impressive range of time-places (see the introduction to this volume). There are obvious objections to a universalising, essentialising interpretation of breakage in the enormous diversity of cultural contexts in which this has been demonstrated (e.g. Rezi 2011; Evangelista & Valera 2019; Guernsey 2020; Chittock this volume). Yet the linkage of breakage to the umbrella term ‘enchainment’ does not prescribe specific interpretations but rather allows the identification of different ways of linking the itineraries of people, places and objects in ways that promote a comparative approach.

Similar comparative advances can be distinguished in fragmentation methodology. A compelling parallel in independent approaches to fragmentation

on two different continents concerns Guernsey's (2020) research on figurine breakage in Preclassic Mesoamerica and our own work on Balkan Neolithic figurines (most recently, Chapman & Gaydarska 2022). Multiple examples of the same criteria used to document deliberate fragmentation have been found independently in both regions, providing strong grounds for accepting the practice of intentional figurine fragmentation in either region even without the convergence of many criteria. However, the clear evidence for parallel practices in figurine fragmentation in the two regions reinforces the argument for its intentional nature, which has a very high probability. Moreover, Guernsey (2020:111) suggests that

the creation, discard, dispersal and disposal of fragments was central to the maintenance of social order (in Mesoamerica) for thousands of years." In her view, "fragmentation was a social tool whose success hinged, in part, on its participatory nature, which required acts of remembering and interpreting on the part of individuals who were compelled for their well-being to perform appropriately.

Above all, breakage was both a transformative, generative and communicative act in the Mesoamerican Preclassic (Guernsey 2020:112). This view of fragmentation could be extended to many, if not most, of the case studies presented in this volume as well as in many other studies, although unintentional breakage (Gaydarska this volume) and 'fake' fragments (Röst this volume) are also well documented. I shall explore this interpretation in several of the case studies discussed below.

A typical trajectory of new research directions shows the move from a first stage of enthusiastic acceptance, via a second stage of critique showing the limitations of the approach, to a third, perhaps more mature, stage of investigation in which strategies are introduced to meet the earlier criticisms. I recognise that fragmentation studies have moved into the third research stage, which is marked by an appreciation of much more fluidity and dynamism in our notions of places, persons and objects than had been shown earlier. But the potential of this more dynamic approach, with its emphasis on communication, cannot be fully realised if we continue to overlook the significance of landscape fragmentation.

### **The inclusion of place in fragmentation studies**

An image depicting the identity triangle (Figure 18.1) has long been part of our research on social archaeology (Chapman & Gaydarska 2007, fig. 1.2). The form of the equilateral triangle shows that each term is of equal importance, while the arrows show the recursive relations between each pair of terms, which together constitute the emergence of identity. However, although

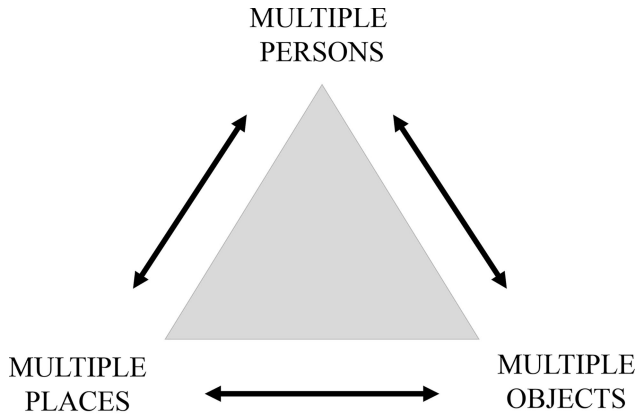

### The relational identity triangle

FIGURE 18.1 The relational identity triangle (source: author, re-drawn by Astrid A. Noterman).

places regularly feature in both our fragmentation books (Chapman 2000; Chapman & Gaydarska 2007), we have made no explicit mention of the fragmentation of landscape insofar as persons visiting specific places often removed parts of those places as ‘raw material’ to make objects, structures, or monuments.

In one sense, this omission is comprehensible; after all, the deliberate breakage of a figurine on a Balkan tell is a very different practice from the removal of a lump of diorite from a boulder field for future use as an axe. While the former showed a person interacting with an artificial entity to produce different entities, the latter involved a person interacting with natural places that remained, if not intact, then in the same overall form in order to produce an object. But if we step back and consider the relationship of parts to wholes in a broader sense, it becomes clear that the ubiquitous removal of stone, clay or metal from their sources to other sites left a series of marked places in the landscape, which sometimes revealed themselves as physical traces – scars, gouges or wounds. Richard Bradley (2000:88) suggested that finished products from unusual locations were not only artefacts with a history of their own’ but also ‘pieces of places’, which carried their places of origin across the landscape to their places of use and eventual deposition. This is a perfect summary of the first stage of objects in general, which involved the fragmentation of the landscape in order to retrieve the ‘raw material’ for the making of ‘complete’ objects from damaged places. A complementary idea to Bradley’s formulation is the general principle enunciated by Chris Gosden

(2009:183) that ‘values attached to materials and to place are mutually referential and supportive’.

There can hardly be a better project to illustrate the significance of landscape fragmentation than Pierre Pétrequin and his colleagues’ impressive ‘Jade’ project, which uses spectro-radiometric analysis to track the source of jadeite axes found over much of Europe to individual outcrops and boulders (‘boudins’) primarily in the Alpine regions of Mont Viso and Mont Beguia (Pétrequin et al. 2012). The analyses of 1,630 axes and over 2,500 jadeite source boulders revealed over 100 ‘spectro-facies’, each of which was defined by a unique petrographic signature (Errera et al. 2012) to show how stone was broken off a source boulder or outcrop and moved to the lowlands and on to other regions. Almost 30% of the spectro-facies showed axes deposited in different regions across Europe, including Spectro-facies 156, linking the Alps to Nantes, Schleswig-Holstein and Lower Saxony, and Spectro-facies 443, linking the Mont Beguia area to the Morbihan and Denmark. Perhaps the most spectacular result was the links between four axeheads almost certainly made from jadeite from the same parent ‘boudin’ on Monte Viso – one found near Dunfermline, Scotland and the other three in northern Germany (Sheridan et al. 2011, fig. 4), documenting landscape fragmentation at the scale of 1,300–1,800 km. This interaction dwarfs the current longest physical refit, in the Chuckwalla Valley of California, USA, between a sandstone block found on a settlement, which could be re-fitted to an outcrop in its source quarry 63 km away (Singer 1984).

The fragmentation of places is therefore the origin-metaphor for the general process of relating in the world, viz., enchainment. But the fragmentation of such places goes much further than this metaphor. This allows a reformulation of the Fragmentation Premise as follows: *‘Places, human bodies and objects were regularly deliberately fragmented, and the resulting fragments were often re-used in an extended use-life ‘after the break’.* It is the links between places and a characteristically open-ended series of other places that mark out enchainment as central to the creation and maintenance of social life. An approach focussed on the itineraries of objects provides a holistic means of re-integrating people, places and objects (Chapman 2022). Now that we have re-instated place in the fragmentation agenda, we can turn to the other main development of multiple objects.

### **A re-consideration of multiple objects, persons and places**

I have already alluded (p. 291) to a deeper appreciation of fluidity and dynamism in our notions of places, persons and objects, leading to a more truly relational approach. An example of this development concerns the replacement of the narration of object biographies by attention to multiple objects (Jones et al. 2016; Jones & Guardamino 2019; cf. Olsen 2010). Multiple

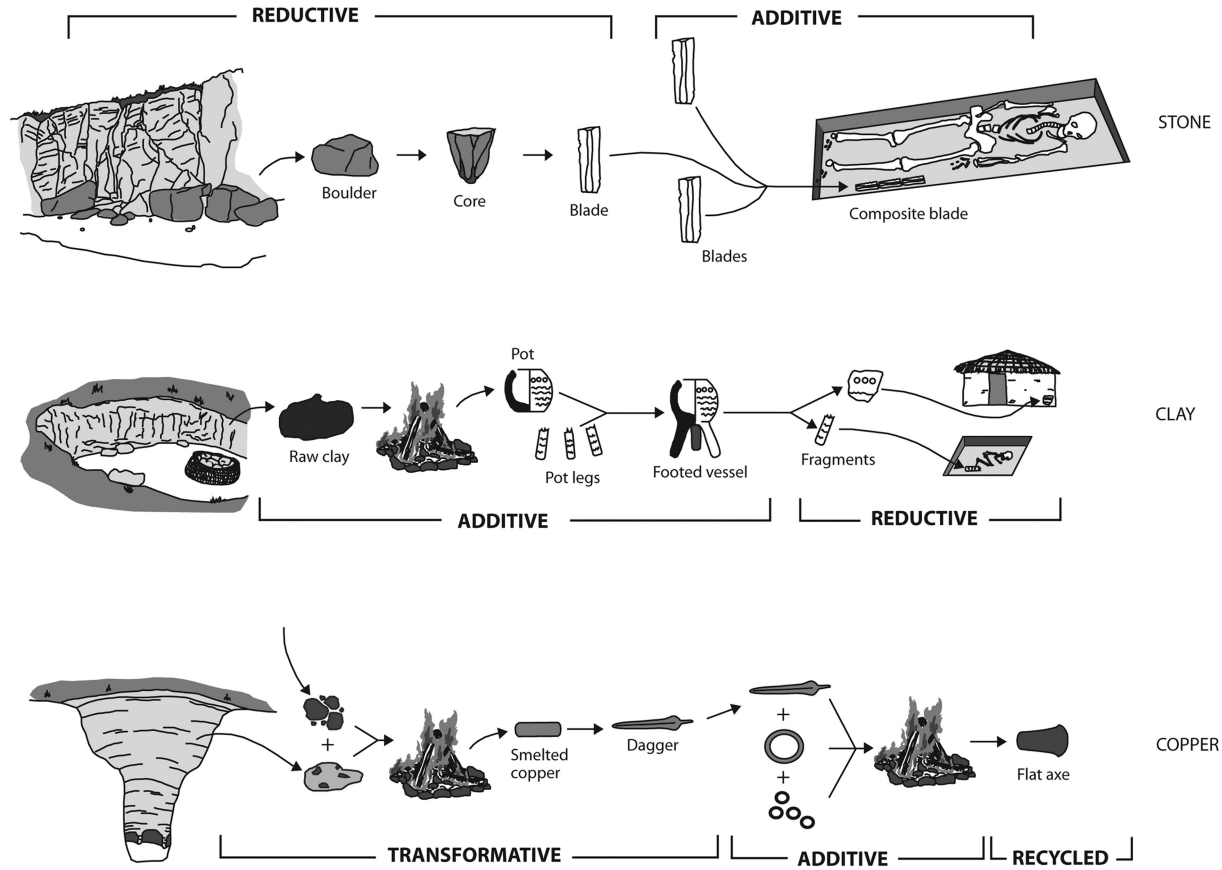

FIGURE 18.2 Operational chains for the process of fragmentation (source: L. Woodard).

objects have been considered to be ‘multiple’ in two ways. First, Jones et al. (2016) extended the notion of multiple objects to the stages through which objects, decorated or not, pass on their life journey from birth (making), life (use) and death (deposition or destruction). In the second way, Jones & Guardamino (2019:194) argue that decorated objects are multiple objects “precisely because they are composed of a series of different and overlapping relations” cited by the decorative motifs or styles that connect them to other time-places. Both aspects of multiplicity will be evaluated in this chapter. Indeed, the notion of multiplicity is not limited to objects but can be extended to cover persons (cf. Fowler 2004) and places (cf. above, p. 292), so that each stage of the fragmentation operational chain, whether reductive, additive or combined (Figure 18.2), can be conceptualised as a different entity, each linked relationally to other different entities. In this sense, ideas of multiplicity are deeply rooted in the process of fragmentation, which is constantly producing ‘new’ dividual entities – what Jones et al. (2016) have called ‘new objects’ – as well as new places and new persons. It is worth turning to some examples of these ‘new’ entities, beginning with new objects.

### Multiple objects

Jones et al.’s (2016) study of the decorated slate plaques of the Manx Neolithic emphasised that every time a plaque was re-worked, a ‘new’ object was created, with several examples of decoration over earlier incisions showing a complex itinerary marked by changes in relational networks. This was also the case with the way that complete pots were regularly fragmented, with undecorated ‘orphan’ sherds placed in a modest proportion (14%) of all Late Bronze Age cremation graves studied by Louwen (this volume). A similar practice has been long known from Copper Age burials in Hungary and interpreted as materialising enchainment links between the living and the dead (Chapman 2000: 51–53; Table 3.3) through the process of *synecdoche*, the symbolic representation of the whole by the part. The reverse practice of the extraction of a small sherd from an otherwise complete vessel has recently been observed in Iron Age graves in the UK (Chittock this volume). Not only did this materialise the enchainment links between the lands of the living and the dead, but the new objects formed framed the kinds of dominant and sub-dominant relationships between the surviving ‘body’ of the vessel and the missing sherd. The different practice of sharing sherds from the same vessel between several graves is attested at Merovingian sites such as Bulles and Saint-Vit (pers. comm. Noterman). Another quite different and equally striking practice concerns the re-working of shoe buckles placed in one grave into belt fasteners placed in another grave at the Early Mediaeval site of Bülach, Switzerland (pers. comm. Noterman). As far as I am aware, no one has yet tried to refit ‘orphan’ sherds between graves in the same cemetery, and this would be



FIGURE 18.3 The entangled links of the repaired *Spondylus* bracelet, Grave 43, Varna cemetery (source: author).

an important future research task, potentially as revealing as genetic links between burials (Alterauge et al. 2021).

An example of the creation of multiple objects whose final form was as a grave good is the repaired *Spondylus* shell bracelet from Grave 43 in the Varna Chalcolithic cemetery (Ivanov 1988), with an AMS determination of OxA-13683 dating the skeleton to 5720±29 BP (Higham et al. 2018; Figure 18.3). The object started life in the Aegean Sea as a large spiny shell, probably recovered from a depth of several metres. It was either exchanged as an intact shell or made into a rough form ready for exchange northward. It is improbable that the shell was worked into a finished bracelet at an Aegean site since the large, thick form was typical of the Western Pontic Coast rather than the Aegean region. At exactly which site the bracelet was made remains unknown, but the Hamangia tradition of ornaments made from the larger, right-side shell, dating from 5200–4800 cal BCE (Chapman & Gaydarska 2007), suggests a West Pontic origin. Studies of *Spondylus* ornaments from the Varna and Durankulak cemeteries show that the mortuary costumes of adult males and females, as well as children, all included *Spondylus* bracelets (Chapman & Gaydarska 2007, Chapter 7). The long use-life of the bracelet is indicated by the heavy surface wear, as the bracelet was gradually transformed into an ancestral ornament. The wear was so great that eventually the bracelet broke. Instead of deposition in a grave – the usual fate of a broken ring – the Varna community repaired the bracelet with another high-status material – gold, probably from a local alluvial source – thus creating a further, decorated stage in this multiple object. The *repoussé* decoration was made using a tool of probably local flint in a style well known from local bone figurines and other gold foil ornaments. The choice to place the ornament in the ‘richest’ grave of the Varna cemetery represented the final transformation into another new object, this time associated with a plethora of grave goods, including a gold penis sheath, cast gold plates and a costume trimmed with gold and carnelian beads – all placed with a 40–50-year-old male with an arthritic knee (sometimes inaccurately described as ‘the Lord of Varna’: Ivanov 1988). The trajectory of this particular multiple object encompasses six stages, linking long-distance exchange, specialist craftsmanship and a spectacular mortuary performance, with a range of different enchainment links at each stage of its multiple life.

Another interpretational shift based on the potential of enchainment concerns the approach to bronze objects. Ojala and Sörman (this volume) have identified at least four ways of developing new bronze objects in addition to the selection of fragments for deposition: filling-up through the addition of castings; fusing, or the joining of parts; patching, in which small parts are added; and up-cycling, in which an object is transformed into another object. Sörman (this volume) identifies the fragments produced in these processes as ‘memorabilia’, whereby the stages in the object’s journey are associated

with the persons and places in which the transformations occurred. The most dramatic changes in interpretation have related to hoards, especially the concentration of bronze fragments once termed ‘scrap hoards’, supposedly assembled as ‘raw material’ for future melting and re-casting (Rezi 2011). The patterning in hoard fragments shows that bronze fragments gained meaning through the way they were broken (Knight this volume), with fragments passing through several new life stages, including their use, curation and re-use (Jones this volume). The use of metal analyses to differentiate the sources of objects in hoards has obvious potential here (cf. Knight this volume).

One of Ojala and Sörman’s (this volume) object transformations relates to the incorporation of parts of old objects into new things. Some of the most dramatic examples related to Iron Age practices, such as Chittock’s (this volume) recognition of fragments from six different bronze objects into the assembly of the decorated Grimthorpe shield, are comparable to the way that the Ferry Fryston chariot was made from parts of several other chariots.

S. J. Watts’ (2014) research into querns in the prehistory of South West England is one of the few in-depth studies of this generally unloved, usually undecorated object class, based upon a sample of almost a thousand objects – mostly fragments, with very few paired stones found together and deliberate fragmentation implied by the continuing possibility of the fragment’s use (2014: 58, 61, 130). Most querns were deposited in settlement contexts, expressing a wide range of symbolism (2014:56). Watts summarises this diachronic pattern as follows: ‘quernstones were deposited with different levels and layers of meaning and intent, which can be determined by the condition of the querns as found in the archaeological record’ (2014:126). The creation of ‘multiple objects’ is well illustrated by the huge variety of deposit types in which the fragments were placed ( $n = 26$ ). In Brück’s (2006:305) view, “each deposit captured the essence of, or harnessed the situation that gave rise to, the deposit”.

We have moved far beyond early studies of a class of objects, such as ‘prosopomorphic lids’ or ‘fired clay maps’, in which the first priority was to identify a pattern of deliberate breakage in an object category (Chapman 2000). Such fluid, dynamic approaches to objects point the way to a deeper understanding of objects as memorabilia, provided that the history of individual objects as well as hoard assemblage is incorporated into fragmentation studies.

### **Multiple places**

The significance of origin-places in the fragmentation chain has been more recently identified than the fragmentation of persons and objects (see above, p. 291 ff.). The transformation of places through time produces ‘multiple places’

at three different spatial scales: the individual context, the site and the landscape. In each case, fragmentation processes are developed in what effectively emerge as ‘new’ places.

At the smallest scale, there has been a problematisation of the notion of ‘closed contexts’, in which doubt has been cast on whether *any* context could have been completely closed<sup>3</sup>. Strong patterning in the removal of certain human body parts – mostly skulls – from sub-floor burials in houses at Çatalhöyük shows different ways of creating ‘history houses’ in contrast to the less elaborate stories of other structures (Hodder 2016). With each retrieval of human remains, the house takes on another layer of ancestral presence and absence, linking the house to other places in the settlement and accumulating a richer network of ancestral veneration.

Similar research on Chalcolithic and Bronze Age burials in Britain has shown the histological potential for differentiating bones removed from burials and bones curated outside the mortuary context, usually in settlements (Brück & Booth 2022; Brück this volume). This means that we cannot assume that disarticulated bones were always curated for long periods before reburial in a ‘new’ place, although the median curation period for Chalcolithic and Early Bronze Age human remains was double that for the Middle-Late Bronze Age (90 years cf. 43 years: Brück & Booth 2022). This leads to a re-evaluation of the recent assertion made by Wallduck (2013) on the basis of her *archéologie du terroir* research into the Iron Gates Mesolithic and Neolithic burials that the operational chain of disarticulated burials was much more complicated than that of the ‘primary’ burials (viz., articulated and (relatively) complete).

It is apparent that every burial context is a potential storehouse of human remains and objects, which can be transformed into a ‘new’ place by the removal or addition of entities (see Noterman this volume). In our past interpretations, we have focussed more on the bodies and grave goods than on the way in which the place of burial is perhaps more subtly transformed. It is now time to redress that balance.

Expanding the scale of place, I turn to Pauketat’s (2013) key observation on site development: with every major new political decision to create a different plan through the addition, modification or destruction of a significant feature, a ‘new’ site is created. His examples from the monumental Cahokia low-density urban centre emphasise the difference between building in the less permanent earth or in timeless stone (Pauketat 2013). But Pauketat’s principle is as valid at small ‘domestic’ Bronze Age settlements such as Leskernick, Cornwall, UK (Bender et al. 2007), where the addition of a new stone-and-turf roundhouse creates a ‘new’ version of the settlement for re-working past site networks and developing new enchainments.

An intriguing example of the creation of new places comes from Late Bronze Age Holland, where a group of seven cremations was brought from

an older site to establish a new urnfield (Louwen this volume) – a literal example of the moving of one ancestral place to make another. A similar accretion of value concerns the Bronze Age deposition of human bones in ‘liminal’ places, such as the place of a bronze hoard or the edge of the fen (Brück this volume). This recursive relationship between human remains, often broken special objects and places highlights the potential for transformation, which could not have been generated by only one such element. These examples underline the widening range of contexts in which the role of fragmentation and subsequent ‘life after the break’ can play in the creation of ‘new’ places.

At the widest scale of place-studies – the landscape – a significant new line of approach concerns the fragmentation of the land, as in the creation of field systems (locally termed ‘reaves’) on Dartmoor, South West England (Fleming 1988). Wickstead (2008) challenges the traditional interpretation that coaxial landscapes developed from processes of fragmentation and territorialisation, as ‘territories’ became attached to households and lineages in a form of social fragmentation (Fleming 1988). While Wickstead’s critique accepts that land itself **was** fragmented from an earlier state of open pasture, she postulates that land division does not equate to social fragmentation but, instead, provided opportunities for a proliferation of relationships – expanded inter-connections between groups. In this account, land division is a way of constructing landscapes to enable the expansion and mobilisation of a network of interests (2008:110). Hence, seen through the lens of land tenure, the multiple authorship of the reaves has more to do with kinship than with ownership, with their layout revealing their connections with other places (2008:147). Ultimately, land divisions showed new ways of expanding distributed personhood because tenure was part of the constitution of identity (2008:155, 163). Wickstead’s analysis is an important milestone in fragmentation studies, in part because it considers the process at a far wider spatial scale than most other fragmentation studies but, mainly, because it emphasises the positive effects of land fragmentation on the relational emergence of values, persons and land.

### **Multiple persons**

The preceding discussion of mortuary places (p. 299) emphasised the emergence of ‘new places’, but I could equally have prioritised the emergence of ‘new persons’. This process has been observed in many contexts, from the deconstruction and later re-assembling of Saami reindeer bone fragments to tell a story and convey a sense of animal personhood (Fjellström this volume; Hull this volume) to the transformation of the deceased human body through cremation to produce a ‘new body’, using the division of the ashes, variable curation, partial re-deposition and associations with new objects (see Louwen

this volume). The ontological turn (Witmore 2014) builds on the tension between individual and dividual aspects of personhood, whether to emphasise dividual aspects of mortuary practices in so-called ‘individual’ burials in the British Early Bronze Age or to suggest that, in time-places where bodily fragmentation of the deceased was the norm, the individual in life was transformed into the dividual in death (for the subtraction and addition of human body parts in Balkan Neolithic – Chalcolithic burials, see Chapman 2010). Chittock (this volume) summarises well the current thinking about human bodies, which undergo complex sequences of transformation and fragmentation as a result of the emphasis by turn on dividual and relational identities.

A spectacular example of such mortuary transformations concerns the 7,500 human bone fragments deposited in the multiple ditches of the Final Linearbandkeramik (or LBK) enclosure at Herxheim, a lowland site in the Palatinate, Germany (Zeeb-Lanz 2016, 2019). Dated to the 51<sup>st</sup> century cal BCE, the ditches had received deposits of human and animal bone fragments, over 15,000 sherds and almost 6,000 lithics; most of these collections have been subject to re-fitting experiments (e.g., pottery: Denaire 2019). The human bones had been dismembered soon after death, and the bones were subsequently smashed with many burns. Zeeb-Lanz (2019) explains this extraordinary deposit as a mass sacrifice of human captives from a different ethnic group after inter-village raiding. This is a very complex phenomenon, and the explanations given here are grossly simplified. But the sacrificial ‘explanation’ does not explain the strontium and oxygen isotopic analyses showing that over 90% of the buried population, estimated at 1,200 persons, was non-native to Herxheim, with 75% coming from hill country or low mountains. Although no upland sites are currently known for the Latest LBK phase, provenance studies show that Herxheim was connected to other LBK sites at least 200 km away in exchange networks for chipped stone, ground and polished stone and pottery.

An alternative explanation starts from three key observations: most of the Herxheim bodies came from upland sites; the Herxheim human remains were radically incomplete; and the material deposited in the Herxheim ditches was not the refuse by-product of rituals but, rather, deliberate deposits. One radical way to explain all three points is the construction of a mobility scenario (Figure 18.4), in which multiple persons who died in upland settlements (and also some lowland sites) were curated there but soon dismembered for movement to Herxheim<sup>4</sup>. Modelling this scenario based on the duration of Herxheim at 20 or 50 years means total annual movement of, for the former, 5 sets of human remains from 9 upland sites or 3 sets from 15 upland sites; and for the latter, 3 sets from 6 upland sites or 2 sets from 9 upland sites. These modest figures show that the mobility scenario was indeed feasible to explain the human bone accumulations at Herxheim. In this scenario, people passed through four multiple states: the living humans became corpses, then

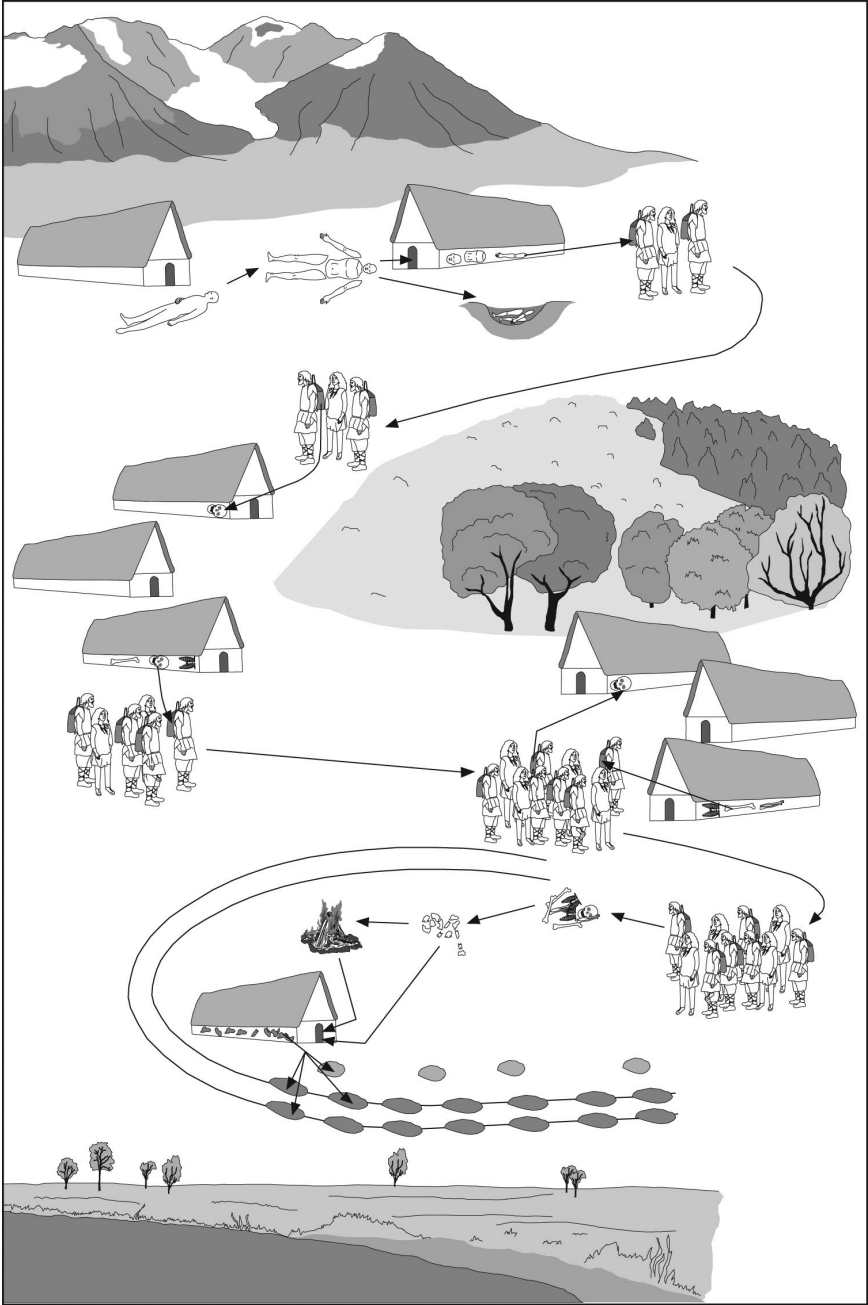

**FIGURE 18.4** A model for the movement of upland body fragments to the lowland enclosure of Herxheim (source: L. Woodard).

were dismembered, then smashed at Herxheim and finally buried. Evangelista and Valera's (2019) comment on the Portuguese site of Perdigões applies equally well to Herxheim: "human bones in enclosures built the strength of each enclosure".

### Discussion: relational identities

A decisive shift towards an understanding of the multiplicity of objects, places and people is consistent with an interpretational move towards relational identities. It is hard to imagine how dividual identities cannot lead towards multiple versions of people, places and objects. Indeed, one may claim that multiplicity is an inherent feature of relationality, with each aspect of an entity occupying locations that change and evolve in a time-place citational field (cf. the topological field of Plutniak, this volume). However, there is no doubt that the principle of multiplicity makes the definition of citational fields more complex, as we can see from the example of the repaired *Spondylus* bracelet from the Varna cemetery discussed above (see p. 297). It will always be a matter of archaeological judgement as to which entanglements out of a vast range of relevant connections constitute the key relationships.

One aspect of relationality that has emerged from the earlier discussion is its status as an important social resource. On a human level, we may contrast the burial of older persons with few if any grave goods, possibly because most of their kin and friends have already died (Parker Pearson 1999, Chapter 4) or because their social 'value' has declined, with the burial of a community leader, such as the adult male in Varna Grave 43, whose connections were at a lifetime peak, resulting in the widest range of grave goods deposited in the entire cemetery (Ivanov 1988). In this sense, the quantity and diversity of grave goods across a cemetery may not have been directly related to social 'wealth', however that problematic term is defined, but rather to the diversity or density of relations between the deceased and her network, viz., a mark of their dividuality.

On a landscape level, Wickstead's (2008) account of the Dartmoor reaves prioritised tenure as part of the constitution of identity, part of how persons matter (2008:1), and therefore more to do with kinship relations than with ownership (2008:24). Just as Bronze Age houses on Dartmoor embodied multiple significances in political as well as family relations, described as 'engines of relatedness' (2008:110), so the reave boundaries were laid out so as to reveal their connections with other places as part of their values (2008:147). The often precise measurement practices used to lay out the reaves emerged from, and generated, fractal personhood **because** (my emphasis) they valued relationships (2008:148).

Generalising this account to other forms of settlement, it becomes feasible to suggest that one of the key functions of the layout of landscapes,

enclosures, forts, cemeteries, houses or pits was the provision of increased opportunities for the proliferation of relationships. An example of this approach to Neolithic causewayed enclosures was to emphasise the importance of the physical work of ditch-digging to the social process of site formation (Whittle et al. 1999), re-visited here as a site-specific layout enabling the creation of new relationality, e.g., between kin groups excavating adjacent ditch segments.

In her otherwise fascinating study of re-opened graves in Early Mediaeval *Reihengräberfelder*, Noterman (this volume) scarcely touches on the way the arrangement of graves reciprocally influences the relations between the deceased and their mourners. There could well be tension between the two principal topological relations: the relations of the grave lines to each other and the relations of the individual graves to each other within the lines and even between lines. Two prehistoric parallels concern the Late Neolithic grave lines, most of them focussed on houses, in the intramural burials at Kisköre-Damn and the Early-Middle Copper Age cemetery of Tiszapolgár-Basatanya, where grave rows dominate the cemetery (Chapman 2000a). At each site, grave lines were a form of self-structuring social practice where kinship calculus was defined not only by inclusion or exclusion from the line but also by the relative position of the grave in the line and distance from the ancestral line (2000a:71–72). It was not only the selected place of the cemetery that created potential for the expanded growth of relationality but also the choice of the form of the graves in parallel lines, which further developed this potential.

A final consideration concerns Mauss' insight that the act of exchange crystallised all previous exchange relations as well as the cultural relations providing the context for that exchange act (Masclef 2018). Could it be implicit in the logic of multiple objects, places and persons that each new version of a multiple entity provoked a similar crystallisation of previous relational networks through, e.g., commemorative ceremonies, with each transformation linked to potentially different audiences? This suggestion raises many interesting implications that need to be worked through in future research on relational identities.

### Concluding remarks

In this essay, I have ranged widely across and beyond fragmentation research in an attempt to discuss the implications of relational identities and their inherent connection to multiplicity through the changing stages in the biographies of persons, objects and places. These discussions lead to three significant conclusions:

- 1 The incompleteness of the earlier version of the Fragmentation Premise, involving objects and persons but not places, has been remedied to include

a new version. Here, the fragmentation of places to produce ‘resources’ for the making of objects, their future use and later fragmentation are given a central place as the origin-metaphor of social relations, viz., enchainment. There is still much work to be done on the various forms of enchainment that connect places, persons and objects. An example of place-fragmentation at a continental scale is provided by the Jade Project (Pétréquin et al. 2012), in which, for example, fragments of the same jadeitite block in a remote Alpine valley have been made into axes deposited as far away as North Scotland and North Germany (Sheridan et al. 2011).

- 2 There are two senses in which Andrew Jones’ (Jones et al. 2016; Jones & Guardamino 2019) notion of ‘multiple objects’ can be developed: in time, as different, overlapping stages of decoration change the ‘same’ object; and in place, where motifs decorating one object relate to the same motifs on remote objects in different cultural contexts. The idea of multiplicity can also be extended to places and people, both of whom pass through different stages of transformation in their lives. Far from watering down the original concept, the idea of multiple persons conveys the sense in which, for example, human bodies grew and changed in life while, in death, they were transformed, often through fragmentation, as their dividual identities continued to change. This recursive process of multiple identities is well summarised in Bradley’s view of objects as ‘pieces of place’, in which fragmented places were presented by the objects to which they gave rise.
- 3 The key finding of this chapter is that multiplicity is an inherent feature of relationality which developed through the fluid and dynamic lives of places, persons and objects. With key exceptions, such as Wickstead (2008), we have perhaps underplayed the notion of relationality as a significant social resource that could be drawn upon at various times in its life but was also a reason for the very existence of the places we call sites. In other words, the potential of the construction of sites (and landscapes) for the expansion of social relations was much more than simply a by-product of site formation but was, rather, its primary function. Just as we have devoted much, and invaluable, attention to the physical aspects of site formation and taphonomy ever since Schiffer (1987), we have undervalued the social aspects of the process. A final speculation prompted by Mauss’ work on the act of exchange raised the possibility that each successive transformation of multiple places, persons and objects crystallised the entire cultural world of the time-place.

In the discussions at the workshop from which this volume originates, I concluded my presentation by posing the question of how our fragmentation research/this workshop relate to the struggle against climate disaster, as recently highlighted in the COP 26 UN Climate Change Conference. While the issue of climatic disaster can never be diminished or pushed into second position behind another issue, many of our views on the world have been

transformed by the war in Ukraine. How are these two processes linked to each other and to recent archaeological research, including fragmentation?

In my view, both the climate disaster and the Russian invasion of Ukraine have common roots in our failure to value our deepest links to nature and other people. Our interdependence on nature is so obvious that it has taken decades of business-led propaganda and economic deception to promote climate scepticism. Equally, the monstrous portrayal of Ukraine as a ‘non-state’ and Ukrainians as ‘non-persons’ relies on political propaganda and historical deception to underpin the invasion. In the words of Rebecca Liu reviewing the 2022 film *Futura* (Guardian Weekend magazine, 9th July 2022), the neo-liberal establishment portrayed by adolescents in that film foregrounds a world of fierce economic competition, which celebrates the entrepreneurial individual breaking free of the collective. It is this fetishism of independence and the individual that seeks to contradict the tight links between humans and nature, as well as between humans and other humans. As in the varied perspectives on new materialism and post-humanism, our research on fragmentation posits an alternative to neo-liberal individualism: human relations underpinned by the collective and the values created by such relationality. It is a huge job, involving academics, policymakers and activists from across the full spectrum of political thought, to transform this alternative theoretical approach into a coherent political strategy, let alone a programme of policies. But a world where the connections forming individual relations with nature, animals and other humans already offers the promise of a different future.

## Notes

- 1 To discover that we have in fact been discussing the ontological turn since 2007 reminds me of the citizen in Molière, who suddenly discovers that he has been speaking ‘prose’.
- 2 Victoria Coren Mitchell hosts the quiz show ‘Only Connect’ for BBC2.
- 3 However, a voice of dissent comes from Thomas (1999:87), who argues that pits were dug to forge a link between people and place, with their contents becoming a permanent memorial and, therefore, a ‘closed’ context.
- 4 For references to the many examples of the movement of human bodies across the landscape, see Chapman et al., in press.

## References

- Alberti, B. et al. eds. 2016. *Archaeology after interpretation: returning materials to archaeological theory*. London: Routledge.
- Alexander, C. 1979. *The timeless way of building*. Oxford & New York: Oxford University Press.
- Alterauge, A. et al. 2021. Beyond simple kinship and identification: aDNA analyses from a 17th–19th century crypt in Germany. *Forensic Science International Genetics*: 53. <https://doi.org/10.1016/j.fsigen.2021.102498>

- Bailey D.W. 2001. Book review of Chapman (2000). *American Anthropologist* 103(4): 1181–1182.
- Bender, B. et al. 2007. *Stone worlds: narrative and reflexivity in landscape archaeology*. Walnut Creek, CA: Left Coast Press Inc.
- Bradley, R. 2000. *An archaeology of natural places*. London: Routledge.
- Brittain, M. & Harris, O. 2010. Enchaining arguments and fragmenting assumptions: reconsidering the fragmentation debate in archaeology. *World Archaeology* 42(4): 581–594.
- Brück, J. 2006. Fragmentation, personhood and the social construction of technology in Middle and Late Bronze Age Britain. *Cambridge Archaeological Journal* 16(2): 297–315.
- Brück, J. & Booth, T. 2022. The power of relics: the curation of human bone in British Bronze Age burials. *European Journal of Archaeology* 25(3): 1–23.
- Bunting, M. 2021. Review of Mosse 2021. *Guardian Weekend* 22/V/2021.
- Cambridge Archaeological Journal. 2021. Special section: debating Posthumanism in Archaeology. *Cambridge Archaeological Journal* Issue 31(3). <https://doi.org/10.1017/S0959774321000135>
- Chapman, J. 2000. *Fragmentation in archaeology: people, places and broken objects in the prehistory of South Eastern Europe*. London: Routledge. <https://doi.org/10.4324/9780203759431>
- . 2000a. *Tensions at funerals. mortuary archaeology in later Hungarian prehistory*. Budapest: Archaeolingua.
- . 2010. ‘Deviant’ burials in the Neolithic and Chalcolithic of Central and South Eastern Europe. In: K. Rebay-Salisbury et al. (eds) *Body parts and bodies whole*. Oxford: Oxbow Books, 30–45.
- . 2022. The fragmentation of place: towards an integrated theory of fragmentation. In: M. Grygiel & P. Obst (eds) *Walking among ancient trees. Studies in honour of Ryszard Grygiel and Peter Bogucki on the 45th anniversary of their research collaboration*. Łódź: Fundacja Badań Archeologicznych Imienia Profesora Konrada Jażdżewskiego Muzeum Archeologiczne i Etnograficzne w Łódzi, 635–648.
- Chapman, J. & Gaydarska, B. 2007. *Parts and wholes: fragmentation in prehistoric context*. Oxford: Oxbow Books.
- . 2022. The meaning of deliberate figurine fragmentation: insights from the Old and New Worlds. In: G. Miniaci (ed.) *Breaking images. damage and mutilation of ancient figurines*. Oxford: Oxbow Books, 14–50.
- Chapman, J. et al., in press. New perspectives on deliberate fragmentation and bodily mobility. *Germania*.
- DeLanda, M. 2016. *Assemblage theory*. Edinburgh: Edinburgh University Press.
- Denaire, A. 2019. Pottery re-fits and connections from Herxheim. In: A. Zeeb-Lanz (ed.) *Ritualised destruction in the Early Neolithic: the exceptional site of Herxheim (Palatinate, Germany) Volume 2*. Speyer: Generaldirektion Kulturelles Erbe, 25–40.
- Dumitrescu, H. 1927–1932. La station préhistorique de Ruginoasa. *Dacia* 3–4:57–87.
- Errera, M. et al. 2012. Spectroradiométrie, référentiel naturel et étude de la diffusion des haches alpines. In: P. Pétrequin et al. (eds) *Jade. Grandes haches alpines du Néolithique européen. Ve et IVe millénaires av. J.-C.* Besançon: PUFC, 440–533.
- Evangelista, L.S. & Valera, A.C. 2019. Segmenting and depositing: the manipulation of the human body in ditched enclosures seen from Perdigões. In: A.C. Valera

- (ed.) *Fragmentation and depositions in pre- and proto-historic Portugal*. Lisbon: Núcleo de Investigação arqueológica (NIA), 47–70.
- Fleming, A. 1988. *The Dartmoor reaves: investigating prehistoric land divisions*. London: Batsford.
- Fowler, C. 2004. *The archaeology of personhood. an anthropological approach*. London and New York: Routledge.
- . 2008. Fractal bodies in the past and present. In: D. Borić & J. Robb (eds) *Past bodies. Body-centered research in archaeology*. Oxford: Oxbow Books, 47–57.
- Gosden, C. 2009. Afterword. In: B. O'Connor et al. (eds) *Materialitas. working stone, carving identity*. Prehistoric Society Research Paper 3. Oxford: Oxbow Books, 181–184.
- Guernsey, J. 2020. *Human figuration and fragmentation in Preclassic Mesoamerica. from figurines to sculpture*. Cambridge: Cambridge University Press.
- Hamilakis, J. & Jones, A.M. 2017. Archaeology and assemblage. *Cambridge Archaeological Journal* 27(1): 77–84. <https://doi.org/10.1017/S0959774316000688>
- Harman, G. 2018. *Object-Oriented Ontology: a new theory of everything*. London: Pelican Books.
- Higham, T. et al. 2018. AMS dating of the Late Copper Age cemetery of Varna, Bulgaria. *Radiocarbon* 60(2): 493–516. <https://doi.org/10.1017/RDC.2018.9>
- Hodder, I. 2016. More on history houses at Çatalhöyük: A response to Carleton et al. *Journal of Archaeological Science* 67: 1–6. <https://doi.org/10.1016/j.jas.2015.10.010>
- Ivanov, I. 1988. Die Ausgrabungen des Gräberfeldes von Varna: Die Konsequenzen. In: A. Fol & J. Lichardus (eds) *Macht, Herrschaft und Gold. Das Gräberfeld von Varna und die Anfänge einer neuen europäischen Zivilisation*. Saarbrücken: Moderne Galerie des Saarland-Museums, 49–66.
- Jones, A.M. 2005. Lives in fragments? Personhood and the European Neolithic. *Journal of Social Archaeology* 5(2): 193–224. <https://doi.org/10.1177/1469605305053367>
- Jones, A.M. & Díaz-Guardamino, M. 2019. *Making a mark. image and process in Neolithic Britain and Ireland*. Oxford: Oxbow Books.
- Jones, A.M. et al. 2016. From artefact biographies to ‘multiple objects’: a new analysis of the decorated plaques of the Irish Sea region. *Norwegian Archaeological Review* 49(2): 1–21. <http://dx.doi.org/10.1080/00293652.2016.1227359>
- Lucas, G. 2015. Evidence of *what?* On the possibilities of archaeological interpretation. In: R. Chapman & A. Wylie (eds) *Material evidence. learning from archaeological practice*. London: Routledge, 311–325.
- Masclef, O. 2018. *Penser le don avec Marcel Mauss*. Bruyères-le-Châtel: Nouvel Cité.
- Milisauskas, S. 2002. Interpretations and narratives of the Neolithic of southeast Europe. *Antiquity* 76: 887–889. <https://doi.org/10.1017/S0003598X00091390>
- Mosse, K. 2021. *An extra pair of hands: a story of caring, ageing and everyday acts of love*. London: Profile Books.
- Olsen, B. 2010. *In defense of things: archaeology and the ontology of objects*. Plymouth: Altamira Press.
- Parker Pearson, M. 1999. *The archaeology of death and burial*. Stroud: Sutton Publishing.
- Pauketat, T. 2013. *An archaeology of the cosmos: rethinking agency and religion in ancient America*. London: Routledge.
- Pétrequin, P. et al. eds. 2012. *Jade. Grandes haches alpines du Néolithique européen. V<sup>e</sup> et IV<sup>e</sup> millénaires av. J.-C.* Besançon: PUFC.

- Rezi, B. 2011. Voluntary destruction and fragmentation in Late Bronze Age hoards from Central Transylvania. In: S. Berecki et al. (eds) *Bronze Age Rites and Rituals in the Carpathian Basin*. Târgu Mureş: MEGA, 303–34.
- Schiffer, M.B. 1987. *Formation processes of the archaeological record*. Albuquerque: University of New Mexico Press.
- Sheridan, J.A. et al. 2011. Old friends, new friends, a long-lost friend and false friends: tales from *Projet JADE*. In: R.V. Davis & M. Edmonds (eds) *Stone axe studies III*. Oxford and Oakville: Oxbow Books, 411–426.
- Singer, C.A. 1984. The 63-kilometer fit. In: J.E. Ericson & A.B. Purdy (eds) *Prehistoric Quarries and Lithic Production*. Cambridge: Cambridge University Press, 35–48.
- Talalay, L. 1987. Rethinking the function of clay figurine legs from Neolithic Greece. *American Journal of Archaeology* 91: 161–169. <https://doi.org/10.2307/505214>
- Wallduck, R.J. 2013. *Post-mortem body manipulation in the Danube Gorges' Mesolithic and Neolithic: a taphonomic perspective*. Unpublished Ph.D. thesis. University of Cambridge.
- Watts, S.R. 2014. *The life and death of querns. the deposition and use-contexts of querns in South-Western England from the Neolithic to the Iron Age*. Southampton: Southampton Monographs in Archaeology.
- Whittle, A., Pollard, J. & Grigson, C. 1999. *The harmony of symbols. the Windmill Hill causewayed enclosure*. Oxford: Oxbow Books.
- Wickstead, H. 2008. *Theorising tenure: land division and identity in later prehistoric Dartmoor, south-west Britain*. Oxford: Archaeopress.
- Witmore, C. 2014. Archaeology and the New Materialisms. *Journal of Contemporary Archaeology* 1: 203–246. <http://dx.doi.org/10.1558/jca.v1i2.16661>
- Zeeb-Lanz, A. ed. 2016. *Ritualised destruction in the Early Neolithic – the exceptional site of Herxheim (Palatinate, Germany)*. Volume 1. Speyer: Direktion Landesarchäologie, Aussenstelle Speyer.
- . ed. 2019. *Ritualised destruction in the Early Neolithic – the exceptional site of Herxheim (Palatinate, Germany)*. Volume 2. Speyer: Direktion Landesarchäologie, Aussenstelle Speyer.



# Taylor & Francis

Taylor & Francis Group

<http://taylorandfrancis.com>

# INDEX

Note: **Bold** page numbers refer to tables; *italic* page numbers refer to figures and page numbers followed by “n” denote endnotes.

- age/patina 10, 12, 234
- animal studies 147
- archaeology: historical 183–184; and kinship 55–57; refitting studies 125, 127–128; relational 14; of repairs 225–226; *see also* fragmentation studies
- artefact biography 108, 111, **112**, 113
- assemblage **4**, 254; archaeological 71, 137, 138; of artefacts and ecofacts 207; Bronze Age metalwork 219; of beads 215; breakage or decomposition 2; burial 80; ceramic 76; *chaîne opératoire* 105; comingled 146, 149–151; complex, interrelated, ever-changing 16; of complex MIA metalwork 210, 219; composition of complete 138; constant forming and reforming 16; disarticulated 151; fragmented 126, 151, 208–209, 260, 264, 268; funerary 79; grave 70–72, 79; of IA objects 216, 217, 219; identities of reindeer from 150; of megalithic tombs 9; metalwork 270; mixed 145, 146, 151, 281; new community of 144; or pieces of objects 7; partial reconstruction of objects 137; presence of working animals 151; quantitative and qualitative analyses 151; realities of 152; study of bone 8, 149; theory 3, 14–16, 104
- body: of antler 191; articulated 31–33; bones 75; complete 57, 61; dead 42, 46, 79, 212, 300; dissolution of human 35; disturbed graves 77, 77; fragmented 13, 25–26, 27, 36, 80–81, 218, 302; incomplete 8; manipulations 72; mutilations 9; ornaments 45, 226, 265; and personhood 26; physically discrete nature of 17n1; putrefaction of 8; separation of 8; stress and weight 150; use of 147; of vessel 295
- body part: in BA graves 30; *vs.* body and part *vs.* set 5; circulation of 9; fracturing of 9; human 8–10, 299; recovery of 8
- Brännskåret* 277
- broken artefacts 26, 36–37, 57, 59, 63–64

- broken objects 1, 26, 36, 56–57, 59–60, 63, 71, 86, 103–105, 113, 115, 206, 208, 218, 226, 260
- Bronze Age (BA): Britain 26, 27, 35, 36, 82, 218; broken artefacts 26; burials 27; cultural conventions 247; early (*see* Early Bronze Age (EBA)); Europe 41, 218, 244, 261, 262; fragments of 110; graves 26–31; Irish 82; late (*see* Late Bronze Age (LBA)); metalwork 206, 219, 243, 262, 268; Middle (*see* Middle Bronze Age (MBA)); Nordic (*see* Nordic Bronze Age (NBA)); people, objects and places 51; personhoods 209
- burials: artefacts and skeletal parts 1; assemblage 80; Bronze Age 27, 299; Copper Age 295; dismantle before 214; Early Bronze Age 29, 301; grave 1 93; Iron Age 57–61; inhumation 25–31, 57–58, 210; intact 147; Late Bronze Age 262, 266; Late Iron Age 59; Middle Iron Age 44; oval brooches 95; practices 56, 70–71, 147; primary 25, 31, 299; rituals 60, 62–64; secondary 25, 81; *see also* cemeteries; graves
- cemeteries: breaking artefacts 59; burial rituals 62, 64; cremation 51, 57, 58, 60–62, 297; early medieval 57, 70, 73, 79; Early Iron Age 46; household 60, 63; Iron Age 56, 60, 61, 64; kinship 63; Merovingian 70, 72; Middle Iron Age 214; oldest monument 50; urnfields 41; users of 60, 64, 303; *see also* burials; graves
- cinerary mounds 45
- closed contexts 299
- composite knives or stone-edged bone implements 197
- composite objects 6, 12, 110, 205, 214, 218–219, 225, 237–238
- convention breakers 247
- Copper Age 199, 218, 295, 304
- creative reuse 234
- cremation 6; of adult individuals 47; ancestors at multiple locations at once 49–50; cemeteries 57, 58, 60–62; dominant funerary rite 41, 49; fragmentation and loss of bone 26; graves 43–46; and interment, time between 43, 48; Late Bronze Age 11, 295, 299–300; metaphorical transformation of dead person 42; in mortuary process 47; objects burned with 247; open-air 43; practices in Western world 8; primary 29; stage of 45, 46; transformation of deceased human body 300
- cultural heritage 283–285
- culture of fragmentation 8
- deliberate fragmentation: of artefacts 71–73; of bodies 26, 36, 81, 103; cultural context 275; European contexts 125, 206, 219; evidence of 72; experiments 119; of grave goods 26; of Iron Age objects 207; *vs.* non-deliberate fragmentation 104, 111, 113; object biographies 119; of objects 36, 70; refitting 119
- disarticulation 4; assemblage 151; dead bodies 8, 25, 27, 147, 206; fragments of human bone 26–28, 31, 32, 34–35, 78, 144, 280, 299; skulls and long bones 29, 31
- dismantle 4, 144, 190; before burial 214; components of objects 214, 215, 225; and fragmentation, difference between 205, 217–219; Middle-Late Iron Age metalwork 210; vehicles 214; wrecks 275, 281
- disturbed graves 70–71, 77, 77, 80; *see also* reopened graves
- Early Bronze Age (EBA): adult female dating 26; axeheads in Scotland 245–247, 246, 253; British 9, 27, 31, 301; burials 29; fragmentation of grave goods 26, 30, 31, 34; metalwork 243; organic bags 29
- Early Celtic Art 209–210
- Early Iron Age (EIA) 44, 46, 46, 49

- Early Middle Age 159  
 economic recycling 115  
 egalitarian peasant village societies 42  
 enchainment 4, 6, 290, 293; and  
   accumulation 144, 189; agency  
   117; and fragmentation 87,  
   115, 219; to humans 144;  
   inter-personal 117; issue of  
   17n1; between people, places  
   and objects 15, 189, 297, 305;  
   possibilities of 238; rings 11;  
   social relationships 1, 26
- fake 6, 10, 291  
 figurine 108, 110, 113, 115;  
   anthropomorphic 206; bone  
   104, 297; breakers 118,  
   290–292; Chalcolithic 2, 111;  
   fragmentation 291; makers  
   118; marble 117; Neolithic  
   1, 2, 11, 103, 291; Preclassic  
   Mesoamerican human 3
- Folkton Drums 201  
 fragmentation premise 5, 290, 293, 304  
 fragmentation studies: aim and scope  
   104–105, 108; archaeological  
   perspectives 1–16; Årsta manor  
   175, 175–176; of artefacts  
   25; background 144–145;  
   broken bodies 8–9; bronze  
   objects 297–298; challenges in  
   simulating archaeological 138,  
   138–139; characteristics by  
   material 106–107, 108, 109,  
   110–111; characteristics by  
   scale of investigation 112, 113;  
   creating fragments 206–208; and  
   deceptive memory-making 173–  
   175; definition 3; depositional  
   contexts 111, 113; *vs.*  
   dismantling 217–219; entangled  
   links of repaired *Spondylus*  
   bracelet 296; funerary practices  
   8; future avenues 115, 117–118;  
   heritage of 283–285, 285; in  
   historical archaeology 183–184;  
   human body parts, secondary  
   use of 8–9; inclusion of place in  
   291–293; and incompleteness  
   of reopened graves 72–78;  
   interpretative approaches 4;  
   in Iron Age Britain 205–206;  
   and Iron Age burials in Finland  
   57–61; itinerary of 290–291;  
   modern 13; multiple objects 293,  
   295, 297, 305; multiple persons  
   300–303, 302, 305; multiple  
   places 298–300; operational  
   chains for 294; production debris  
   or recycling 114–115; relational  
   identities 303–304; relational  
   identity triangle 292; selective  
   (*see* selective fragmentation);  
   Sherds refitting 114; social  
   personhood 8–9, 17n1; from  
   source-critical problem to  
   interpretative potential 1–3
- fragments: assemblage theory 14–16;  
 assembling fragments 208–209;  
 avoiding and embracing 115;  
 bodies in Bronze Age graves  
 26–31; bodies in non-mortuary  
 contexts 31–35; counting  
 and non-supervised ordering  
 of matching relationships  
 128–131; counting connection  
 relationships 131–133, 132;  
 creation of reality 13–14;  
 data publication 136–137;  
 definition 3, 5; experimentation  
 137; exposing and imposing  
 deception 181; fusing (*see*  
 fusing fragments); interpretative  
 approaches 6; itineraries of 16–  
 17; kin through 61–64; limits of  
 archaeological observation 135–  
 136; matching sets count and  
 intuitive interpretation 128, 129;  
 as memorabilia 268–270; objects  
 and uncertain archaeological  
 location 124–126; ontological  
 and existential qualities of 5,  
 7–8; post-human perspectives  
 14; properties 9–13; refitting  
 fragments 135–138; relational  
 perspectives 15; reuse of 113,  
 116; for sale 280–283; similarity  
 relationships between 127–128;  
 using artificially generated data  
 137–138
- funerary practices 8, 41, 43–45, 57, 63,  
 79–80, 96–97
- furnished graves and reopening 70–72
- fusing fragments: archaeological sources  
 and source criticism 226–227;  
 archaeology of repairs 225–226;

- bronze objects in Late Bronze Age southern Scandinavia 226; manipulated objects 235–238; metalwork in Late Bronze Age Sweden 227–235; Nordic Bronze Age metalwork 224–225
- graves: assemblage 70–72, 79; Bronze Age 26–31; cremation 11, 43–46; deliberate fragmentation 26; disturbed 70–71, 77, 77, 80; Early Bronze Age 26, 30, 31, 34; furnished 70–72; Iron Age 64; inhumation 10, 57–58, 62, 64; intact 47; Late Bronze Age 11, 35, 295; Middle Iron Age 214; oval brooches 93; plain and simple 41; reopened (*see* reopened graves); robbers 9, 59; set of goods 210; urnfield 42–43, 45–46, 49, 51; *see also* burials; cemeteries
- heritage 184; authorised heritage discourse 275; colonial heritage ventures 7; construction through fragments 173–175; cultural 283–285; dispersed 7; of fragmentation 283–285; physicality of 183; ‘place’ as 174; policy on wreck protection 278; and preservation 283–284; and professional historians 282; salvage project 279; sector handle fragments 7; sites 13, 149; Swedish maritime heritage management 286; underwater 278, 283
- hero dogs 147–148
- human-animal studies 143–146
- Iron Age (IA): assemblages 219; Britain 205–209, 214, 215; burial customs 61; cemeteries 56, 60, 61, 64; concept of family 57; concept of kinship 56–57; deliberate fragmentation 207; dismantling and reassembling 209–210, 215–216; East Yorkshire 210, 211, 212–215, 213, 214, 215–216; fragments 209; funerary rituals 63–64; graves 64; Late Iron Age (LIA); metalwork 215; motivations for reuse and reassembly 215; northern Europe 64; ornament on purposeful things 210; personhood 219; societies in Finland 56–57, 60–62; Torrs Pony Cap 216, 217; types of practice for new objects 219; Wessex analyses assemblages 207
- kinship 4, 6, 62; affinal 55; and archaeology 55–57, 77–79; based alliances or social organisations 62; cemeteries 63; connections between previous users of cemetery 63; consanguineal 55; and family 56–57; and kinship 77–79; ownership 300, 303; post-structural and feminist perspectives 56; relations among animals or beings 14; social 55; symbols and practices 64
- kintsugi 105, 115, 116
- landscape fragmentation 290
- Late Bronze Age (LBA): amber beads 46; Britain 32, 36, 209; bronze castings 236; burials 266; cremation 11, 295, 299–300; depositional traditions of 219; disarticulated bones 34–35; Early Iron Age transition 34; European 225, 259; fragmentation of objects 244, 254; metalwork 12, 227, 228–230, 236, 238, 266, 270; Middle 299; mortuary rites 31; in The Netherlands 44, 299–300; non-mortuary contexts 34; Nordic 11, 238, 260; ‘scrap’ hoards 12, 253–254, 263, 269; sharp-force trauma 34; southern Scandinavia (*see* LBA southern Scandinavia); spectacle fibulas 11; Sweden (*see* LBA Sweden); weapons and weapon hoards 251–253
- Late Iron Age (LIA): ADA 1 165, 166; antler from 165; burial types 59; Finnish cemeteries 64; household cemeteries 60; metalwork 205, 210; Middle 205, 207, 210; Scandinavians 62; south-east England 206; south-west England 207; Stållo foundations,

- Adámvallda 159; *see also* Iron Age (IA)
- LBA southern Scandinavia: approaching fragmented bronze in 262–263; bronze objects in 226, 261–262; hoarding in 261–262, 264; metalwork in 225; *see also* Late Bronze Age (LBA)
- LBA Sweden 228–230, 231; chronology, fragmentation rate and general composition 264–265; fill-ups 227, 231, 231; fusing 231, 231–232, 233; metalwork in 227–235; objects types 265–266; patching 231, 233–234; recognizability 266–268; ‘scrap’ hoards, Härnevi 260, 260, 263–264, 264; upcycling 231, 234–235; *see also* Late Bronze Age (LBA)
- Little Ice Age 165
- Lower Rhine Basin: funerary monuments 44–45; practice of fragmentation 51; related dead 49–51; socialised landscape 51
- memorabilia 182, 275, 279, 298; fragments as 268–270, 297; naval wreck sites 275
- memory 6; communicative and cultural 31; and fragmentation 268; living 183; making 173–175; material culture 5, 7; or social practice 105; photographic 113; social 251
- Middle Bronze Age (MBA) 36; fragmentation of objects 244, 251; ornaments 253, 255; ornaments in southern Britain 247–251
- Middle Iron Age (MIA) 44, 45, 206, 210, 214, 219
- mortuary practices 56; in British Early Bronze Age 9, 27, 31, 301; complexity of 27, 82; crucial stages of 46; as culture of fragmentation 8; diversity and complexity of 82; in early medieval cemeteries 70–71; event of cremation 47; flow-chart 52n1; fragmentation of a person 42; fragmentation of body 25–27; 80–81; Iron Age 206; in Lower Rhine Basin 49; mourning community 42; as narrative 43–44, 45; and non-mortuary contexts 26, 31–35; rituals 59, 62–63
- multiple objects: carved stone balls 194–195, 196; decorated artefacts in Neolithic Britain and Ireland 196–197; enchainment 189; fragmentation and accumulation 189–190; Garboldisham macehead 191–192, 192; Manx plaques 192–194, 193; and multiplicities 197–200; things and events 190
- museum exhibits 1, 7, 16, 90, 117, 190, 194–195, 224
- new objects 219, 295
- non-deliberate fragmentation 104, 111, 113
- Nordic Bronze Age (NBA) 224–225, 260–262, 265, 269
- nuclear family 57
- object biography 16, 114, 119, 293
- orphan fragment 6, 14, 112, 295
- pairs: of archaeological spatial units 135–136; of brooches 86, 88–90, 92–94, 95–97; matching 86, 90, 96–97, 149; non-matching 90, 91–92, 92; parted 94–97; splitting 97
- pastness 5, 173, 182, 184
- personhood: Bronze Age 209; broken bodies 8–9; constructing/ configuring 4, 6; of deceased 34; fractal 303; IA 219; individual and dividual aspects of 301; of individual animals 152, 300; and perceptions of body 26; prehistoric 218; social 17n1, 144
- physical refit 125, 293
- post-mortem 8, 29, 32, 35
- provenance 10, 90, 108, 276, 301
- recycling 105, 108, 117; and conversion 234; economic 115; economic imperatives 36; of objects 36; or production debris 114; or trade 259; of timber 282–283; for utilitarian purposes 118
- refit 113, 125, 136, 293, 295

- refitting studies 112, 119, 128–129, 136–137; in archaeology  
 fragmentation 125, 127–128;  
 of Öcsöd face-pot 119; digital  
 108, 115; fragments of objects  
 125, 131, 135–138, 139, 207;  
 importance of combining insights  
 139; large-scale 119; methods  
 113, 125; morphometric factor  
 133; pottery 136; relationships  
 125; of sherds 113, 114, 117;  
 strength of 132; TSAR method  
 139; use of 108; use of similarity  
 relationships 139
- Reindeer (*Rangifer tarandus*) 157;  $\delta^{13}\text{C}$   
 value 165–167, 166;  $\delta^{15}\text{N}$  value  
 161, 162, 163, 165, 168;  $\delta^{18}\text{O}$   
 value 168;  $\delta^{34}\text{S}$  value 161, 163,  
 166;  $^{87}\text{Sr}/^{86}\text{Sr}$  value 162, 163,  
 167, 168; material 161; method  
 161–162; radiocarbon analysis  
 163, 164; seaspray effect 167;  
 stable isotope analysis 163;  
 Stállo foundations, Adamvalldá  
 157–161, 158; Strontium  
 isotope 162
- related dead: relations between people  
 and objects 50–51; relations  
 between people and people 49;  
 relations between people and  
 places 49–50
- relational archaeology 14–15
- relational ontology 289
- relational perspective 14, 15
- relic 1, 9, 12, 30, 36, 260, 270, 283
- remontage 136
- reopened graves: incomplete bodies 75,  
 77, 77–78; intentional breakage  
 of objects 72–73, 74, 75, 76
- repair 94, 105, 110, 180; archaeology  
 of 225–226; cast-on 227, 231,  
 233; convenient replacements  
 for use in 215; fill-ups 227, 231;  
 Late Bronze Age metalwork  
 227, 228–230, 236; metalwork  
 reused in 205; Nordic Bronze  
 Age 224; spectacle fibulas and  
 neck rings 236; visible 235, 236;  
*wendelrings* 232
- reuse 108; in archaeological literature  
 78; of architectural elements  
 and objects 174; of broken  
 pieces 238; bronze metalwork  
 225; of building materials  
 182; of fragments 1–2, 113,  
 115, 116, 118, 216, 225, 237,  
 261; metalwork 205, 227; and  
 reassembly 215; of scraps 262; of  
 sherds 105
- Schräghalsurns* 50
- scrap hoards 12, 36, 253–254, 259,  
 260, 260, 263–264, 264, 269,  
 270, 298
- sea-spray effect 161, 167
- secondary deposition 4
- selective fragmentation 255; ancient  
 and intentional damage 245;  
 Early Bronze Age axeheads in  
 Scotland 245–247, 246; Late  
 Bronze Age ‘scrap’ hoards 253–  
 254; Late Bronze Age weapons  
 and weapon hoards 251–253;  
 Middle Bronze Age ornaments in  
 southern Britain 247–251; and  
 selective deposition 243–244
- set: belt 73; body and part *vs.* 5; of  
 bones 74; of brooches 94–95;  
 of fragments 125, 132; of grave  
 goods 210; of mismatching  
 components 214; of objects 137;  
 sham 214; toilet 266
- souvenir 1, 12, 148, 276, 282
- strap dress 86
- taphonomy 47, 113, 209, 305
- transformation 35–37, 174, 209, 305;  
*chaîne opératoire* 105; of dead  
 person 42, 300; of form and  
 decoration 110; fragmentation  
 and breaking 13, 16, 301;  
 mortuary 301; of objects 250,  
 297–298; of sites and artefacts  
 25; social 43
- upcycling 4, 227, 231, 234–235, 237
- Viking Age 11, 12, 56, 62, 86–97, 159,  
 163
- waste 2, 5, 16, 262, 283; casting 233;  
 metal 251; production 136–137;  
 sustainable 234
- wholeness 3, 104, 105
- zooarchaeology 145–146